



RS2 Feeder

Operators & Parts Manual



NEW ZEALAND (HEAD OFFICE)
GILTRAP ENGINEERING LTD
7 Main North Road
Otorohanga 3900

TEL: [+64 7 873 4199](tel:+6478734199)
FAX: [+64 7 873 8131](tel:+6478738131)
FREE: [0800 804 458 \(NZ ONLY\)](tel:0800804458)
GENERAL: info@giltrapag.co.nz
PARTS: parts@giltrapag.co.nz
WEBSITE: www.giltrapag.co.nz

Part Number: 13257

AUSTRALIA
GILTRAP AG EQUIPMENT PTY LTD
105-117 Boundary Road
Laverton North
Melbourne
Vic 3026

TEL: [+61 3 936 96 548](tel:+61393696548)
FAX: [+61 3 936 96 549](tel:+61393696549)
FREE: [1800 127 030 \(AU ONLY\)](tel:1800127030)
SALES: sales@giltrapag.com.au
PARTS: melboffice@giltrapag.com.au
WEBSITE: www.giltrapag.com.au

Disclaimer

Although every endeavour has been made to compile as near to complete records as possible for the machine described, it is possible some information is incomplete or missing.

Giltrap Engineering request that you treat this book as a guide only, and offer any assistance necessary to procure the information or part you may require.

For parts or service enquiries, please contact the applicable numbers on the previous page.

Produced February 2026

Copyright © 2026 by Giltrap Engineering Ltd.
Printed in New Zealand

All rights reserved. Reproduction or use, without express permission, of editorial or pictorial content, in any manner, is prohibited.

Table of Contents

INTRODUCTION	4
SAFETY - GENERAL	7
SAFETY – MACHINE SPECIFIC.....	11
PRE-SERVICE GUIDELINES & SETTINGS	12
SETUP & OPERATING INSTRUCTIONS	13
<i>Hydraulic Requirements</i>	13
<i>Setup</i>	13
<i>Loading Instructions</i>	13
<i>Feeding Out</i>	14
MAINTENANCE.....	15
<i>Lubrication</i>	15
<i>Feed Chain Adjustment</i>	16
<i>Before Storing</i>	16
<i>Adjusting Maximum Bale Transport Height</i>	17
PARTS SECTION.....	18
CONTENTS	18
<i>General Layout</i>	19
<i>Bed Assembly</i>	20
<i>Bed Assembly – Machines Built Pre February 2026</i>	21
<i>Chassis Assembly – Machines Built Pre February 2026</i>	23
<i>Chassis Assembly – Machines Built February 2026 Onwards</i>	25
<i>Loading Mechanism – Machines Built Pre February 2026</i>	27
<i>Loading Mechanism – Machines Built February 2026 Onwards</i>	28
<i>String Bin Assembly – Machines Built Pre February 2026</i>	30
<i>String Bin Assembly – Machines Built February 2026 Onwards</i>	31
<i>50mm 6 Stud Hub Monroc</i>	32
<i>50mm 6 Stud Hub Monroc</i>	33
<i>50mm 6 Stud Hub ADR</i>	34

Introduction

Thank you for purchasing a Giltrap product. *Giltrap Engineering Ltd* has enjoyed a long-standing success with their machinery. We would like you to enjoy the benefits of owning a Giltrap too. By following the guidelines laid out in this book, you will ensure trouble free, low maintenance operating for years.

Giltrap Engineering Ltd is a progressive company which continually strives to satisfy your needs, so we welcome any feedback which you can provide to help us improve our products and services and to ensure that they perform to your expectations. Any constructive comments about this operator's manual are also welcome.

Your machine has been designed to perform its task efficiently and with a minimum of maintenance. This handbook provides safety guidelines, instructions, maintenance requirements and parts listings. We recommend that you read the entire handbook, before operating the machine as this will enable you to take full advantage of your new machine's considerable potential.

Manual Evaluation

We update our operating manuals regularly. Your suggestions for improvement help us to create even more user friendly manuals. Send your suggestions by email to admin@giltrapag.co.nz

Delivery and Warranty

Before you begin to use your machine, please check it to make sure there is no delivery damage. If damage is evident, contact the dealer who supplied the machine so that they can make the appropriate claims.

If you have any other queries, please contact your dealer or *Giltrap Engineering Ltd* (0800 80 GILTRAP). All Giltrap products are covered by a 24-month warranty on parts and labour, subject to normal use.

Please fill in the details below for future reference.

Model:
Serial No:
Delivery Date:
Dealer:

Warranty

The Goods specified in the Price List as designed and supplied by Giltrap Engineering Ltd are warranted against faulty workmanship and defective materials for a period of 24 months from the date of purchase. In addition to the primary 24 month warranty for Giltrap products, there is a further 12 month structural warranty for the goods, against faulty workmanship and/or defective materials for structural items only. The structural warranty does not apply to electronics or component parts.

Such warranty is subject to the following conditions:

1. This warranty covers the repair or replacement of parts or machinery sold by the manufacturer and damaged as a result of the faulty workmanship or materials in such parts or machinery. It does not extend to any other loss or damage including consequential loss or damage or loss to other property or persons.
2. Without limiting the generality of paragraph 1 above, this warranty does not cover the following:
 - (a) Travel expenses.
 - (b) Damaged caused by accident, misuse or abuse.
 - (c) Damage to any goods which have been altered or modified by someone other than the manufacturer or its authorised agent.
 - (d) Damage or loss to the goods due to their unsuitability for any particular use or for using with any particular tractor except where such use or tractor had been specifically approved by the manufacturer.
 - (e) Damage or loss where the fitting and installation of the goods were not carried out by the manufacturer or its authorised dealer.

3. Procedure for recovery under warranty.

No loss or damage will be covered by this warranty unless the loss or damage is reported immediately to the dealer (who will contact the distributor who will advise whether it is covered by the warranty and undertake the necessary action).

No warranty repair work is to be undertaken prior to an order number being obtained.

This warranty shall be interpreted according to the laws of New Zealand and the parties agree to submit to the jurisdiction of the Courts of New Zealand.

Warranty Claims

If you wish to make a claim under warranty:

- Immediately stop using the machine.
- List details of the machine and damaged item including serial numbers and date of purchase.
- Consult with your Giltrap dealer (supplier) and have him forward your claim and the damaged item to Giltrap Engineering Ltd.

No warranty to be undertaken unless an order number is obtained from the Seller (Giltrap Engineering Ltd) prior to any work being done.

Serial Number Identification

Before ordering any parts, check the serial number and the delivery date of the machine and include this information with all orders.

If the Serial Number Plate is missing, the serial number will be stamped on the front of the drawbar.



Tel +64 7 873 4199
www.giltrapag.co.nz
7 Main North Road
Otorohanga
New Zealand

DRAWBAR VERTICAL RATING (kg):

GROSS LADEN MASS (kg):

SERIAL No:

MODEL No:

This plate is provided in compliance with the NZ Land Transport Heavy Vehicles 2004 rule, section 4.2. It is the operator's responsibility to ensure that this unit is fully compliant with all current legislation when it is used on public roads. **Removal of this plate invalidates certificate.**

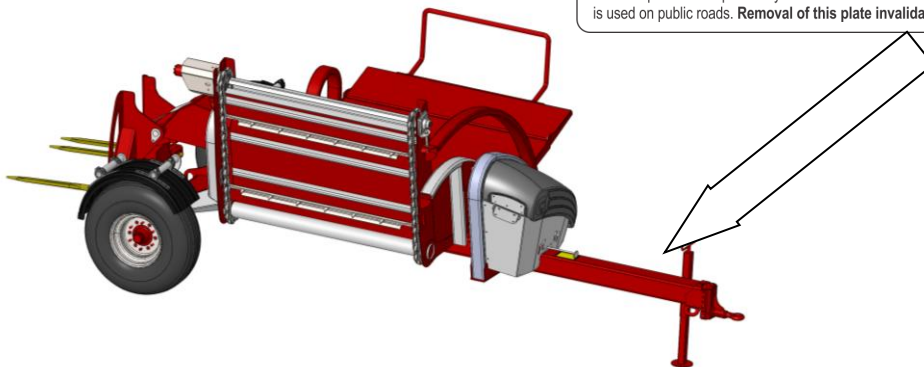

Serial number stamped onto chassis here



Tel +64 7 873 4199
www.giltrapag.co.nz
7 Main North Road
Otorohanga
New Zealand

DRAWBAR VERTICAL RATING (kg):

GROSS LADEN MASS (kg):

SERIAL No:

MODEL No:

This plate is provided in compliance with the NZ Land Transport Heavy Vehicles 2004 rule, section 4.2. It is the operator's responsibility to ensure that this unit is fully compliant with all current legislation when it is used on public roads. **Removal of this plate invalidates certificate.**

Safety - General

This section of the manual offers general guidelines for the safe operation of machinery.

For the safety of others and yourself, please read and follow the precautions in this operator’s manual. Pay particular attention to the following safety aspects of operating machinery.

Do not ride on or allow passengers on the machine.



Always use a recognised hitch pin with a safety clip to hook trailed implements on behind the tractor.

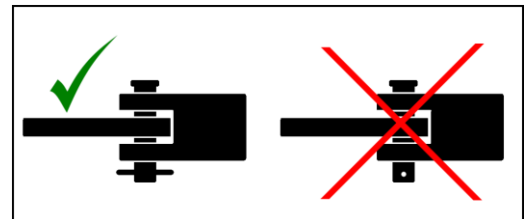

Always ensure when using a quick hitch that the locking tab has come out and is in the locked position before moving.

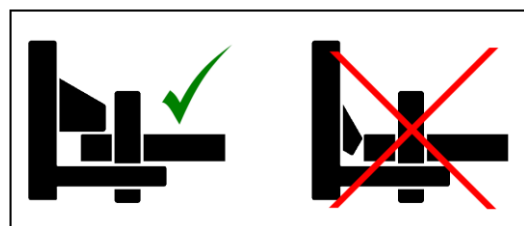

When pulling trailed implements or loads, be sure to use a tractor of greater or equal weight than the combined weight of the load and trailer.

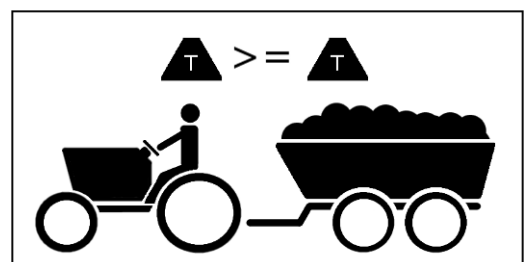

Carry a suitable fire extinguisher.

A fire can ignite under certain conditions, so please take the following precautions:

After running your machine for a short time, check for defective bearings. A faulty bearing can become very hot, eventually discolouring, requiring immediate replacement.

Do not allow combustible material to accumulate inside guards or around rollers and other moving parts.

If your machine becomes blocked, stop immediately and remove the obstruction.

Be careful when operating in hot or dry conditions or on extreme fire risk days.



Never operate your machine without the safety guards in place.



All chains should be properly adjusted and replaced when necessary.

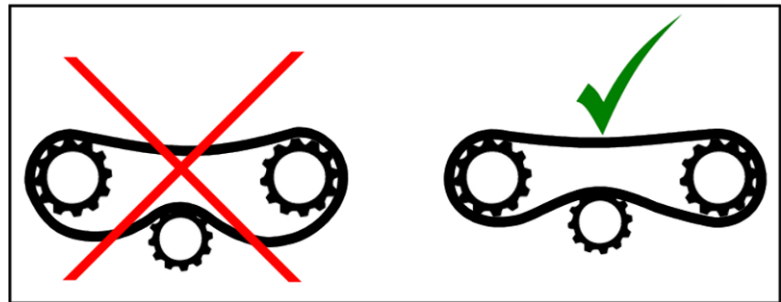

Release all hydraulic pressure from implements before commencing service work. Never look for suspected oil leaks with your hands or body - use a piece of cardboard instead. Any fluid that penetrates the skin will have to be removed immediately by a medical expert. Seek specialist advice on this type of injury.



Never attempt to unblock equipment while it is still operating.
 Always disengage power take-off, hydraulics and shut down engine before removing materials, checking or servicing.
 Failure to follow these precautions is likely to result in serious injury.

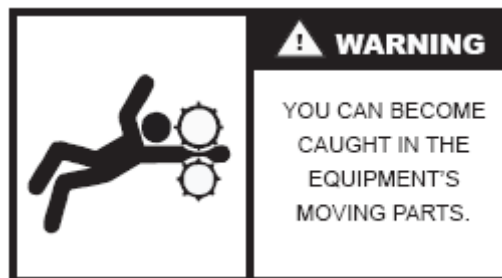

Wear proper protective clothing. Loose attire can easily be snagged by rotating machinery resulting in serious injury or death.



Giltrap Engineering has made every effort to highlight all risks to personnel or property. Owners and operators have a responsibility to exercise care and safe work practices at all times in the vicinity of the machine.

It is the owner's responsibility to ensure that anyone who operates, adjusts, lubricates, maintains, cleans or uses the machine in any way has had suitable instruction and is familiar with the information in this manual (particularly with regard to safety aspects). Operators and other users of the machine should be aware of potential hazards and operating limitations.

Transport This Machine Safely

Ensure that all linkage pins and security clips are fitted correctly.
 With trailing machines tow with the drawbar only, as this is the only safe towing point on the machine. Always check that bystanders (especially children) are well clear (front and rear) before starting and moving the tractor and the machine.
 Plan safe routes of travel, and be aware of power lines and other roadside hazards.
 Take particular care when towing implements on hillsides.
Do not ride or allow passengers on the machine. This machine is not designed to carry passengers, and no riders are permitted.

Road transport

On public roads,

- A speed of 40km/h must not be exceeded.
- Do not operate during the hours of darkness unless standard lights are fitted and clearly visible. (This also applies when visibility is limited, e.g., in foggy conditions.)

See the guidelines in the *Vehicle Dimensions and Mass Rule* issued by the Land & Transport Safety Authority.

Avoid tip-overs

Run the machine along hillsides with the elevator on the high side of the hill. Avoid holes, ditches and obstructions which may cause the machine to tip over, especially on hillsides. Never drive near the edge of a gully or steep embankment - it might cave in. Slow down for hillsides, rough ground and sharp turns.

Avoid High Pressure Fluids

Avoid any contact with fluids leaking under pressure, because the fluids can penetrate the skin surface. Any fluid which penetrates the skin will need to be **removed immediately by a medical expert**. Seek specialist advice on this type of injury.

Relieve the pressure before disconnecting any hydraulic or other lines. Make all repairs and tighten all fittings before re-connection to pressurised fluid.

Keep your hands and body away from any pinholes or high pressure jets. Search for leaks with a piece of cardboard instead of using your hand directly.

General Maintenance

Accidents occur most frequently during servicing and repair. The following general rules must be followed when maintaining or working with machinery:

- All operating and maintenance manuals must be read before and referred to while using or servicing any piece of equipment.
- Turn off all machinery power sources and isolate the machine before making adjustments, doing lubrication, repairs or any other maintenance on the machine.
- Ensure that the machine hydraulics are disconnected from the power source.
- Wear gloves when handling components with cutting edges, such as any ground cutting components.
- Beware of hazards created by springs under tension or compression when dismantling or maintaining the machine.
- It is recommended that you clean the machine with a water blaster or similar apparatus before commencing maintenance.

Make Sure the Machine is Well Supported

When machinery is fitted with hydraulics, do not rely on the hydraulics to support the machine. During maintenance or while making adjustments under the machine, always lock the hydraulics and support the machine securely. Place blocks or other stable supports under elevated parts before working on these.

Electrical Maintenance

Disconnect the electrical supply from the tractor before doing any electrical maintenance.

Welding

With electronic equipment in modern tractors it is advisable to disconnect the machine from the tractor, or at least disconnect the alternator and battery before attempting any welding.

Use Only Genuine Spare Parts

Unauthorised modifications or non-genuine spare parts may be hazardous and impair the safe operation and working life of the machine.

Excess lubricants must be disposed of safely so as not to become a hazard.

Safety – Machine Specific

The lists below are not all-inclusive and serve only to highlight the more obvious areas of risk. The labels attached to the machine are a general reminder that there are hazardous areas on the machine, rather than specifically highlighting all possible hazards.

The machines have been supplied with the following warning labels. It is the user’s responsibility to keep them in visible condition. For label locations on the machine, refer to the Part section.

RS2

<p>Pinch Points/Moving Parts Hazardous areas include:</p> <ul style="list-style-type: none"> • Lifting and lowering of main boom • Unsupported bale dropping 	
<p>Keep Clear Hazardous areas include:</p> <ul style="list-style-type: none"> • Area between machine and tractor • General area around the machine while it is operating • Keep off machine while it is moving • High pressure hydraulic hoses 	
<p>Rotating Chains & Bars</p> <ul style="list-style-type: none"> • Beware of moving parts • Beware of sharp points 	

Pre-Service Guidelines & Settings

Prior to delivering your machine, your dealer should have completed a pre-delivery check. It is beneficial to check the following points before using the machine for the first time.

CHECK ELEVATOR CHAIN TENSION. With elevator fully raised (bed sitting down on stops), exert a pull at the mid-point of the outside elevator face. If necessary, adjust for approximately 20mm (3/4”) of movement from rest outwards.

CHECK ALL WHEEL NUTS ARE SUFFICIENTLY TIGHT.

Wheel Nut Recommended Torque Settings	
M18 Stud	200 ft/lbs or 270Nm
M20 Stud	280 ft/lbs or 380Nm
M22 Stud	330 ft/lbs or 450Nm



CHECK ALL TYRE PRESSURES ARE CORRECT.

Recommended Tyre Pressures	
11.5/80-15.3	60psi 4.1 bar
400/60-15.5	65psi 4.5 bar



CHECK ALL AXLE MOUNTING BOLTS AND NUTS ARE SUFFICIENTLY TIGHT.

Axle Mounting Bolt Recommended Torque Settings	
M16	180 ft/lbs or 245Nm



THERE ARE SEVERAL GREASE POINTS on all Giltrap feeders. Check the yellow label on the side of your machine to see how many grease points there are. You should fully grease everything before running it for the first time. See greasing and lubrication details – Page 15.

REMOVE HEADSTOCK STOPS. These are fitted to prevent tine damage to bed during transport. Ensure these are removed before use as they will affect performance.



Setup & Operating Instructions

Hydraulic Requirements

The RS2 Feeder requires two double acting hydraulic remotes. It is important to use the correct type of quick release coupling ends to suit your tractor couplings as some brands of couplings have different spring tension within the coupling which may impede full oil flow - it pays to check this.

IMPORTANT: Giltrap feeders are fitted with the best type of oil drive motors available which will give years of trouble free usage, provided they are used with clean non-contaminated oil. To avoid costly damage to the motor and also to your tractor pump, ensure the oil used is of the recommended grade and is clean. It is advisable to drain and flush the hydraulic oil system within the tractor if this has not been done recently.

Setup

Park the feeder on level ground. Adjust the swivel drawbar assembly so the drawbar of the feeder remains level when hitched to the tractor.

Loading Instructions

1. Lower rear forks to their lowest position referring to the position indicator on the top of the drawbar as a guide. For larger bales, the forks may be raised slightly as required.
2. Reverse to spear the bale all the way.
3. Lift the bale and bring to the desired position for unwrapping. For looser bales, cut the strings/unwrap with the bale closer to the bed to prevent the bale from falling apart. A loop is provided under the bed extension to tie the cut string to if the bale is sitting on the original knots and cannot be pulled free. Tying the strings to the machine will prevent the strings from getting wrapped around the elevator chain.
4. Lower the bale onto the feedout bed.
5. Retract the forks and reset to the loading position.
IMPORTANT: This must be done after loading each bale to reset the loading arm safety valve.
 The forks can then be moved to the transport position.
6. If required, a second bale may be loaded and held with the lift arm close to vertical. Use the position indicator (see below) on the drawbar as a guide if the arm is obscured by the previously loaded bale.

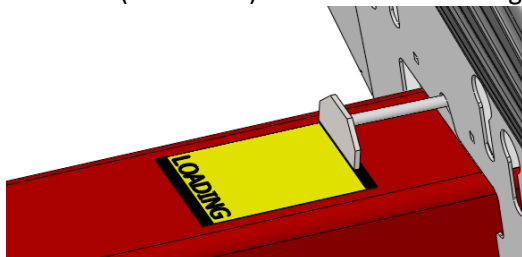

Maximum allowable transport height

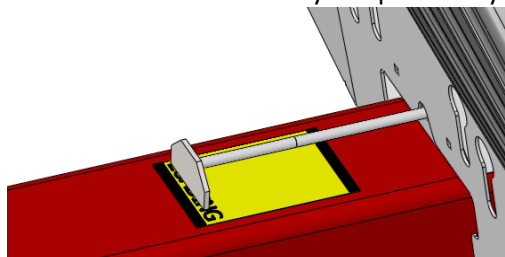

Forks fully lowered into loading position

Feeding Out

Set the tractor hydraulics so the machine is running at 25-30 litres per minute flow.

1. Ensure that all plastic wrapping, mesh and loose string has been removed.
 2. If a second bale is on the forks, ensure that the forks are in the correct position to allow the bed to tilt and feed out. Look at the fork position indicator on the drawbar and move the forks back if required. (See previous page).
 3. The bed may be tilted when feeding out to alter the delivery. The elevator chain tines are aggressive enough to tear the bale.
 4. Round bales rotate and unwrap depending on the original bale winding direction. If too much is being fed out, tilt the bed back to allow the chains to create a flat on the bale; that will stop it from rotating and unwinding too much.
 5. Experiment with the machine and note the different effects depending on which way round the bale was loaded and the various types and ages of feed.
 6. If the elevator chain speed is too fast or too slow, you may need to alter the flow control on the tractor remotes.
 7. When feeding out on hillsides, keep the elevator on the high side of the hill; this reduces the risk of roll-over and gives better control of the bale.
-

Maintenance

The Giltrap Bale Feeder is designed for minimal maintenance. Your Giltrap RS2 Feeder will give long and efficient service if given normal care and maintained properly.

Lubrication

The feed chains should be lubricated on a weekly basis to prolong operational lifespan. Giltrap Engineering recommends the use of food grade chain oil to avoid contamination of livestock feed. To lubricate the chains the machine should be turned over at slow speed, and oil applied to the top of each chain. Car must be taken to avoid contact with the machines moving parts.

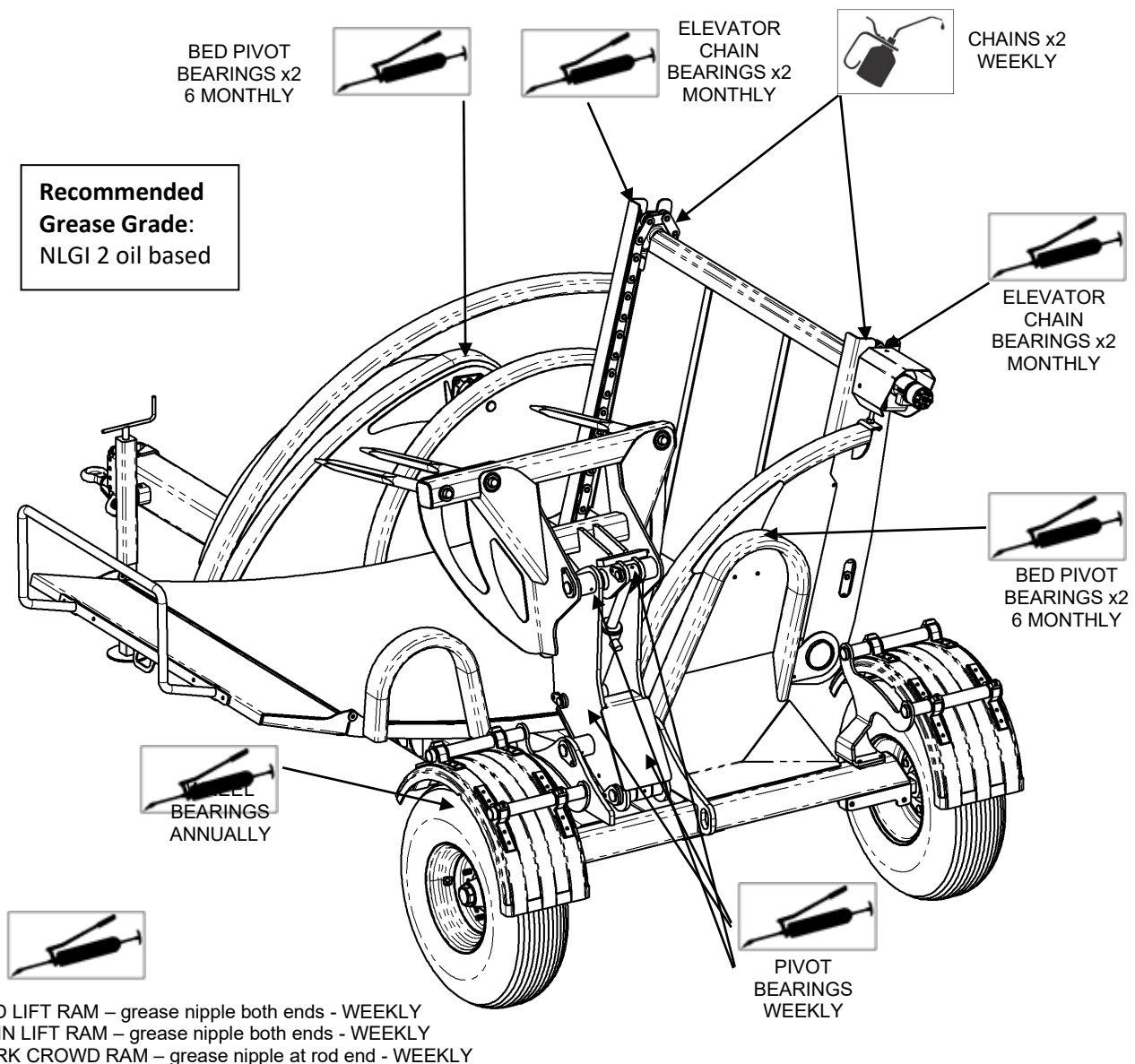

Lubrication frequencies are only a guide. Actual frequency will depend on extent of use and ground conditions.

Feed Chain Adjustment

Check frequently and clean out any build up of debris between the chain links under feed bars. Straighten any bent feed bars and teeth.

Feed chains should not require much adjustment; however, if this should become necessary adjust the chain as below.

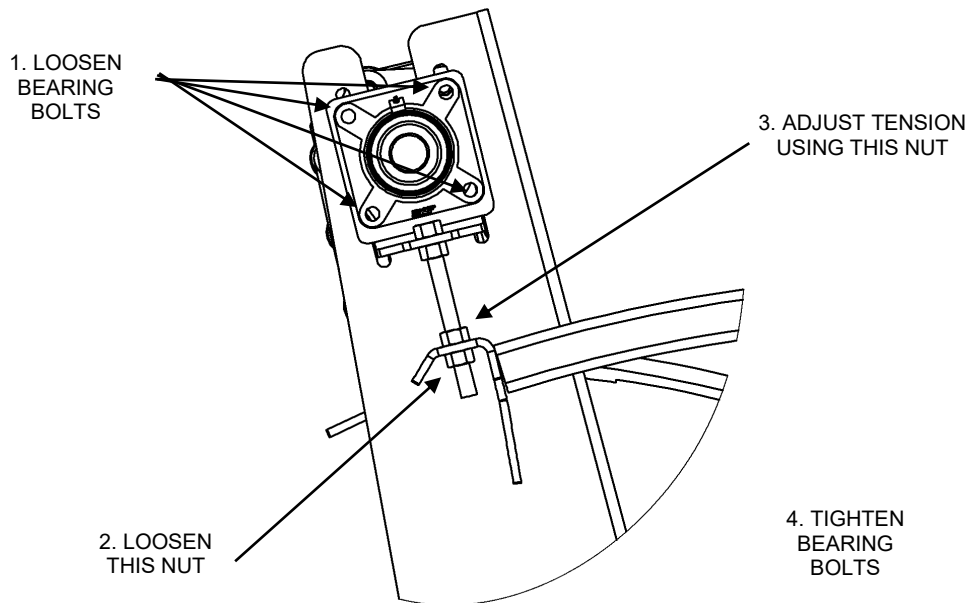

- With elevator fully raised (bed sitting down on stops), exert a pull at the mid-point of the outside elevator face. If necessary, adjust for approximately 20mm (3/4") of movement from rest outwards.

- Adjust both sides evenly

Before Storing

- Clean off any debris etc. and wash machine down, then let machine dry.
- Grease all moving parts and bearings.
- Apply oil liberally to the floor chains, adjust tension if necessary.
- The machine should be stored with the rams retracted to ensure the rods are protected.

Adjusting Maximum Bale Transport Height

- Caution! Setting maximum transport height too high can cause interference between bed and lift boom!

1. Fold boom and headstock over feed bed as shown below:

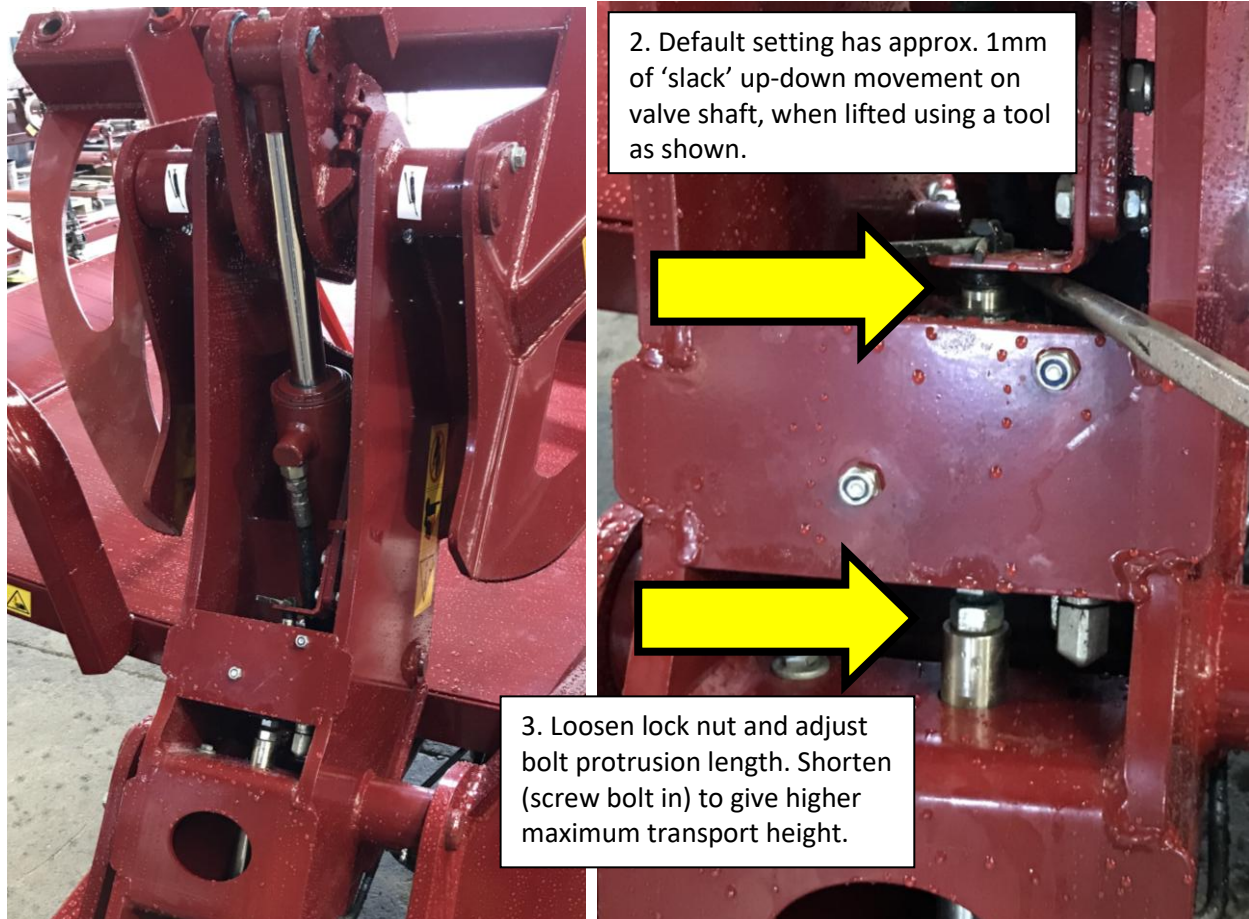

4. Once adjusted, reset boom and lift to maximum transport height. Maximum safe height is reached when boom valve is actuated and prevents hydraulic movement of feed bed.

5. Lower boom until bed can just be raised.
Caution: do not raise bed until check below is completed!

6. Check bed cannot contact boom. See view to Right. Feed bed (blue part on left) must have a gap to Boom (blue on right). If there is interference/overlap, the maximum transport height must be lowered until a gap exists.

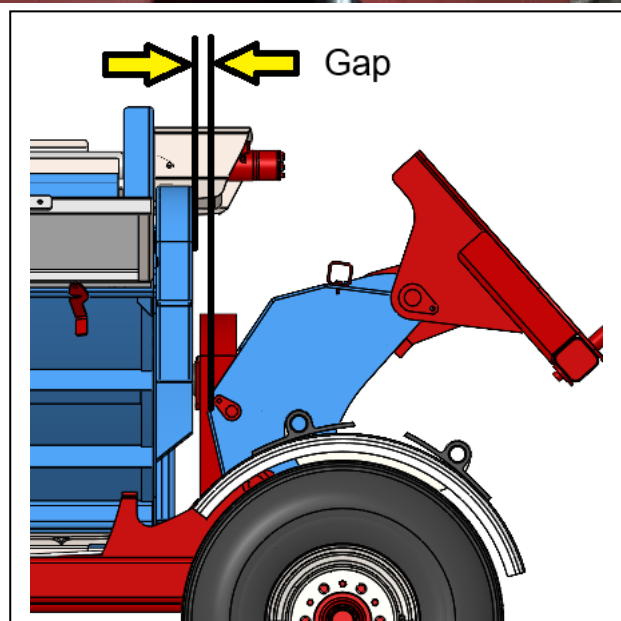

Parts Section

Contents

<i>General Layout</i>	19
<i>Bed Assembly</i>	20
<i>Bed Assembly – Machines Built Pre February 2026</i>	21
<i>Bed Assembly – Machines Built February 2026 Onwards</i>	22
<i>Chassis Assembly – Machines Built Pre February 2026</i>	23
<i>Chassis Assembly – Machines Built February 2026 Onwards</i>	25
<i>Loading Mechanism – Machines Built Pre February 2026</i>	27
<i>Loading Mechanism – Machines Built February 2026 Onwards</i>	28
<i>String Bin Assembly – Machines Built Pre February 2026</i>	30
<i>String Bin Assembly – Machines Built February 2026 Onwards</i>	31
<i>50mm 6 Stud Hub Monroc</i>	32
<i>50mm 6 Stud Hub Monroc</i>	33
<i>50mm 6 Stud Hub ADR</i>	34

General Layout

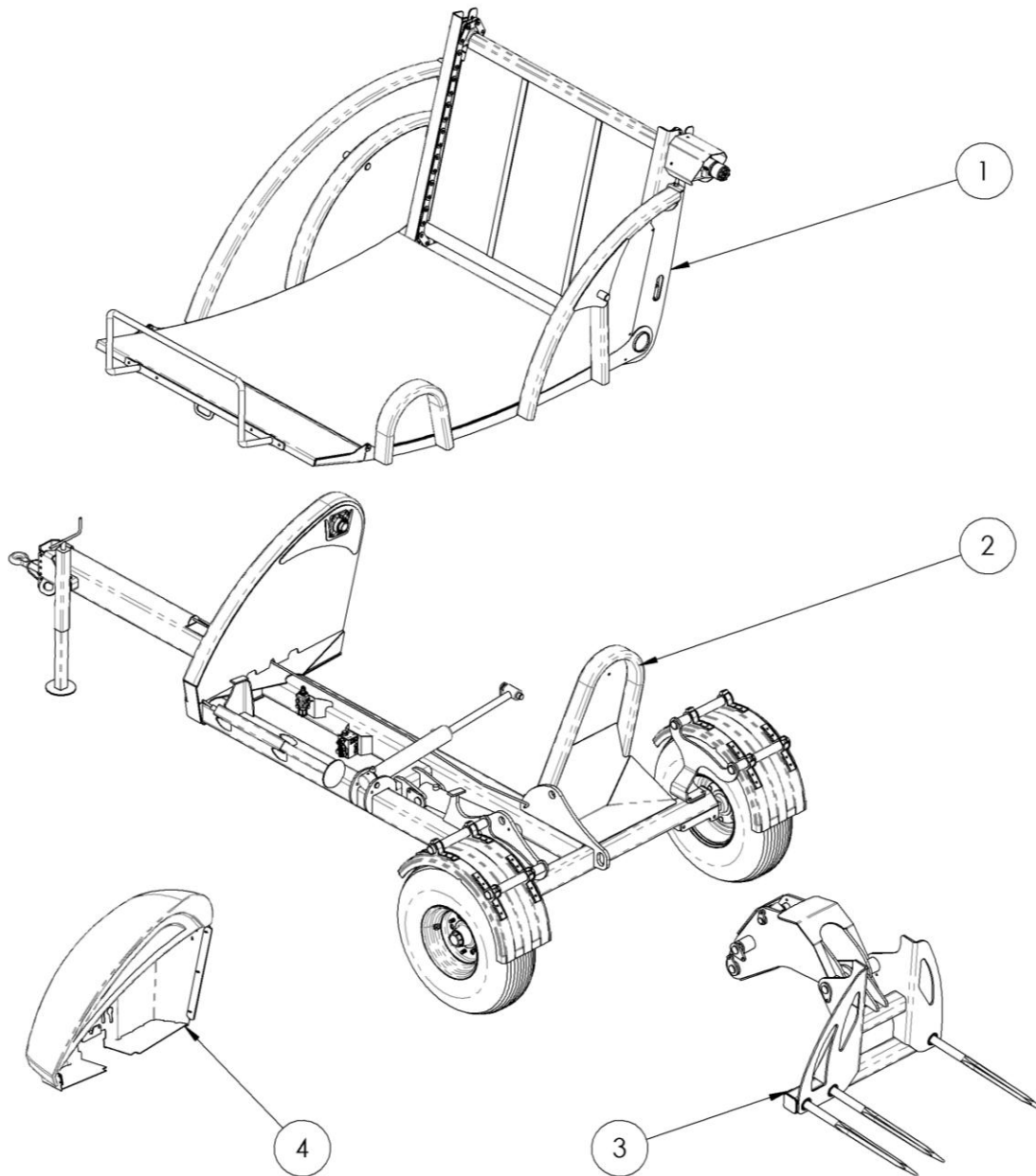

Item	Part No.	Description	Qty
1	Refer below	Bed Assembly	1
2	Refer below	Chassis Assembly	1
3	Refer below	Loading Mechanism	1
4	Refer below	String bin Assembly	1

Bed Assembly

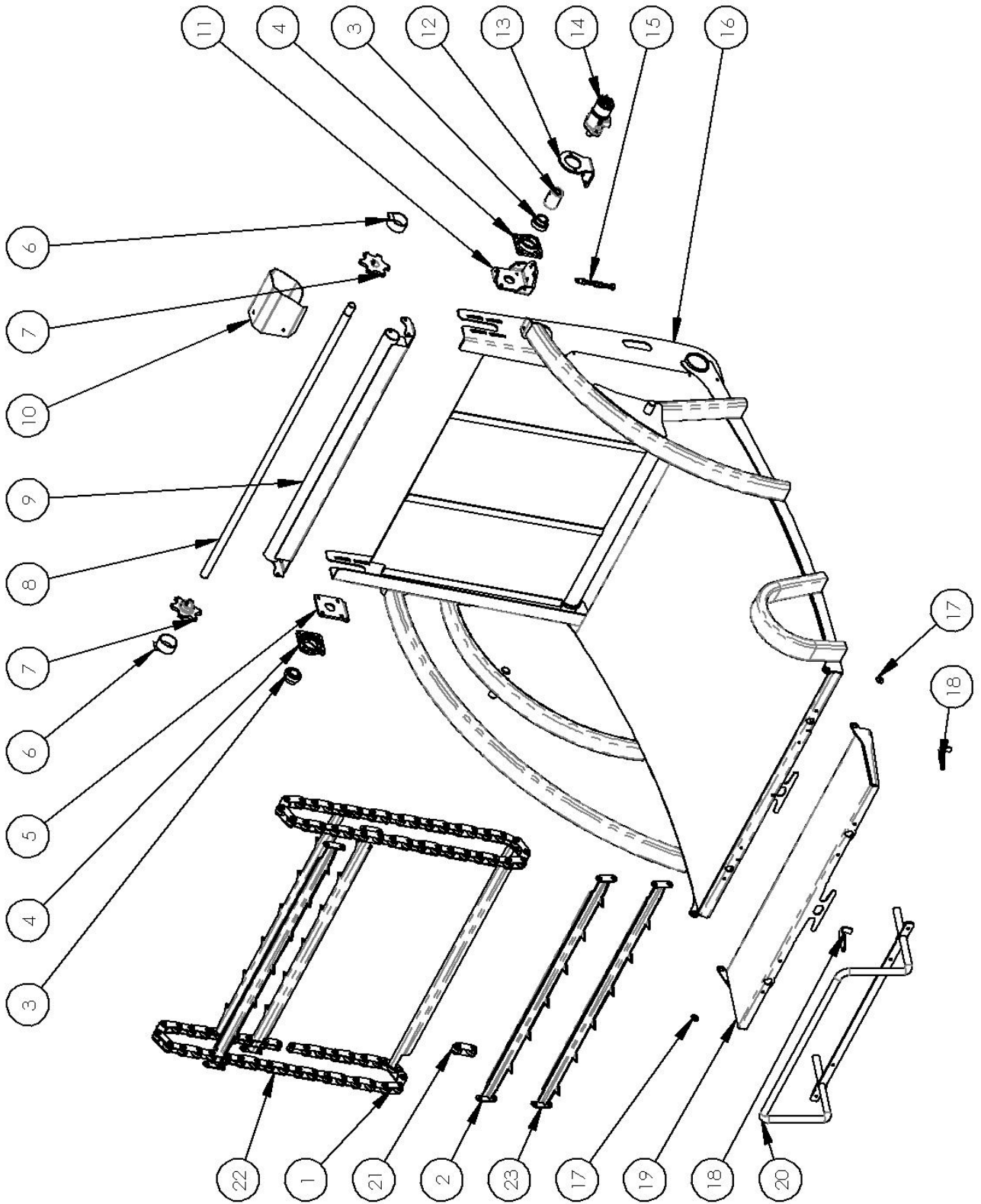

Bed Assembly – Machines Built Pre February 2026

Item	Part Number	Description	Quantity
1	CH15000-3/60	3”P15000LB S/pin conv chain	2
2	14646-R	Elevator Bar-Right Hand	3
3	YET 208	bearing	2
4	FYJ 508	Bearing flange	2
5	12756-9	Bearing adjuster	1
6	12587-12	Sprocket cover	2
7	12620-PT	6T 40mm Bore sprocket	2
8	13151	Drive shaft	1
9	13149	Drive shaft cover	1
10	13146	Motor guard	1
11	12756-14	Bearing adjuster – motor side	1
12	127-2502	Motor drive coupling – 25mm	1
13	12587-2	Elevator motor mount	1
14	HYM400-PT	Hydraulic motor – 400cc	1
15	596-1004	Adjuster screw	2
16	13078	Bed weldment	1
17	12836	washer	2
18	12837	Extension lock handle	2
19	12835	Bed Extension (optional) – 1654mm overall width	1
20	12838	End stop	1
21	CH15000-3CONNECTOR	3” chain connector-15000LBS	12
22	12829	RS2 Chain Assembly	1
23	14646-L	Elevator Bar-Left Hand	3

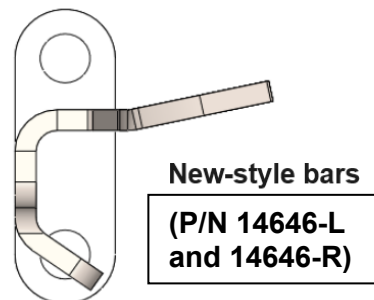
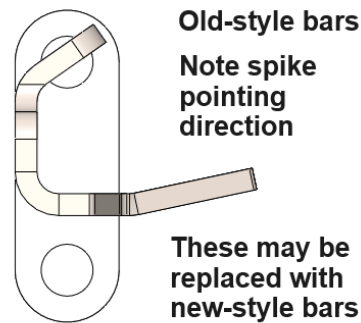
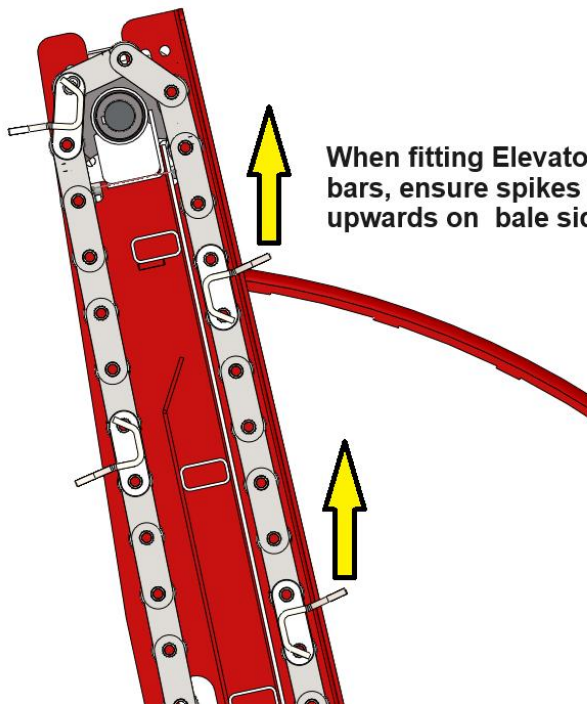

Bed Assembly – Machines Built February 2026 Onwards

Item	Part Number	Description	Quantity
1	CH15000-3/60	3”P15000LB S/pin conv chain	2
2	15123-1-R	Elevator Bar-Right Hand	3
3	BRGYAR208-2F	bearing	2
4	HSGF208	Bearing flange	2
5	12756-9	Bearing adjuster	1
6	12587-12	Sprocket cover	2
7	12620-PT	6T 40mm Bore sprocket	2
8	15383	Drive shaft	1
9	15384	Drive shaft cover	1
10	13146	Motor guard	1
11	13161-1	Bearing adjuster – motor side	1
12	127-2502	Motor drive coupling – 25mm	1
13	13161-2	Elevator motor mount	1
14	HYM400-PT	Hydraulic motor – 400cc	1
15	596-1004	Adjuster screw	2
16	15630	Bed weldment	1
17	12836	washer	2
18	15385	Extension lock handle	2
19	15130	Bed Extension (optional) – 1756mm overall width	1
20	12838	End stop	1
21	CH15000-3CONNECTOR	3” chain connector-15000LBS	12
22	15124	RS2 Chain Assembly	1
23	15123-1-L	Elevator Bar-Left Hand	3

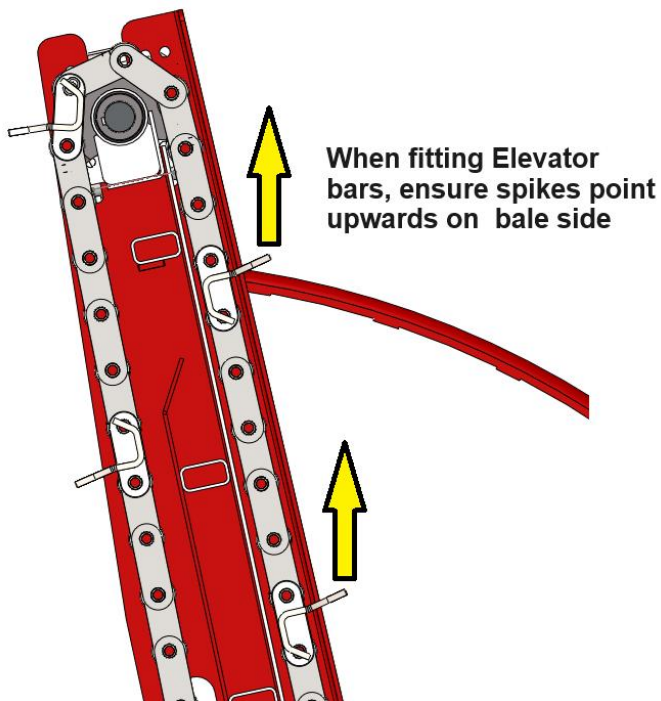

Chassis Assembly – Machines Built Pre February 2026

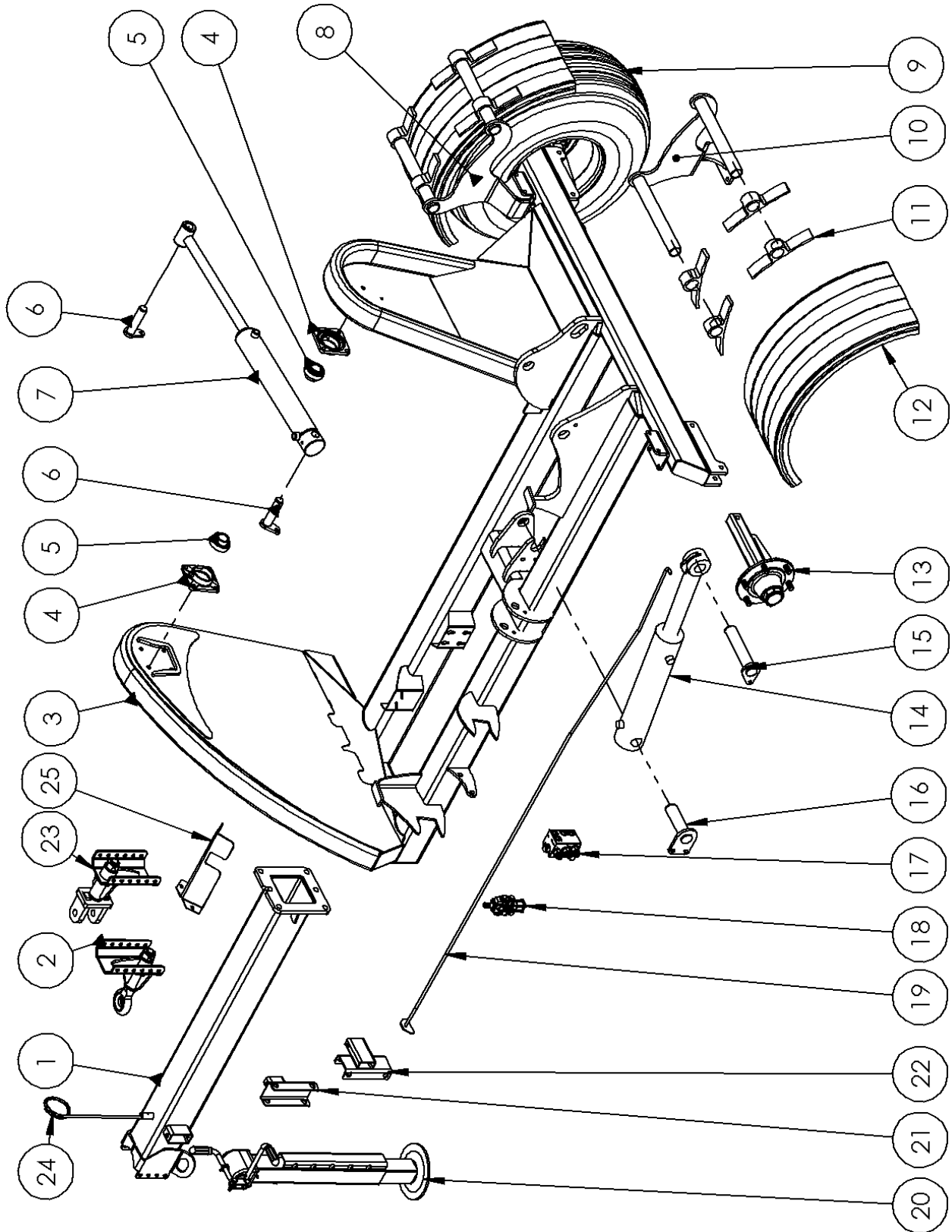

Item	Part Number	Description	Quantity
1	12833 RS2 Drawbar	drawbar	1
2	127-2521	tow hitch	1
2	14403	Clevis Hitch (US Export Models)	1
3	12825 RS2 Chassis	chassis	1
4	HSGF208	bearing flange	2
5	BRGYAR208-2F	bearing	2
6	12845	pin	2
7	RAM3X1.5X468	Bed ram	1
8	12840 RH	Mount bracket RH	1
9	WHLA11.5/80-12	11.5/80-12 Wheel assembly	2
-	(Optional) WHLA400X15.5-146T	Wheel Assy 400/60 X 15.5 - 6 Stud, 14 Ply, Traction	2
10	12840 LH	Mount bracket LH	1
11	Mudguard-saddle	Mudguard bracket	8
12	60939b	Mudguard	2
13	127-2550	50mm 6 stud hub with locator hole	2
14	RAM4X2.5X355	12832 Lift ram	1
15	12843	pin	1
16	12842	pin	1
17	61527	RS2 valve block	1
18	45656	RS2 6 port diverter valve	1
19	12834	Indicator rod	1
20	301-4020	jack	1
21	13670	Jack mount	1
22	14708	Jack mount (post August 2023)	1
23	14575	Clevis swivel tow hitch	1
24	4800315	Hose Holder	1
25	14644	Rod cover	1

Chassis Assembly – Machines Built February 2026 Onwards

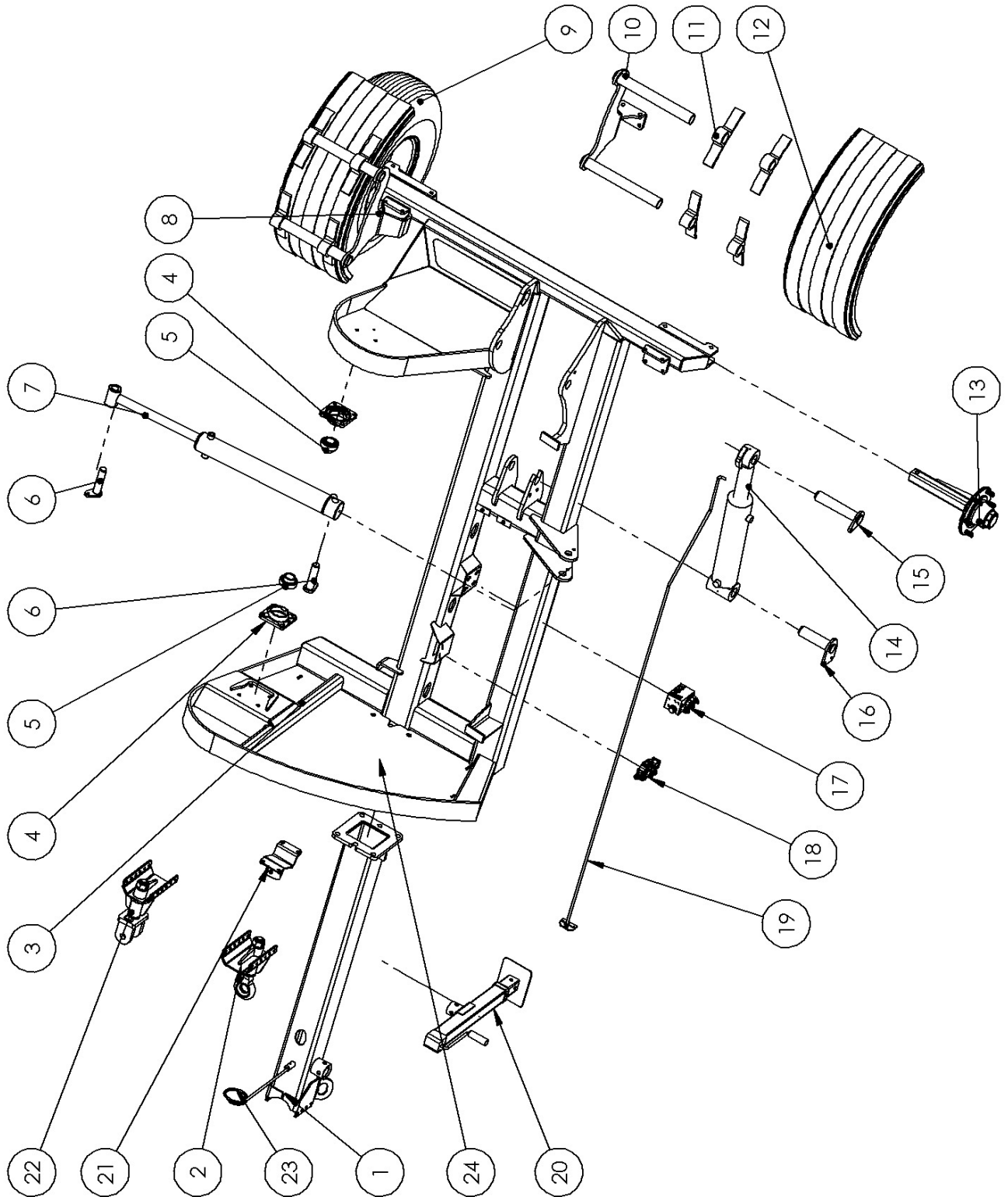

Item	Part Number	Description	Quantity
1	15128 RS2 Drawbar	drawbar	1
2	127-2521	tow hitch	1
2	14403	Clevis Hitch (US Export Models)	1
3	15631 RS2 Chassis	chassis	1
4	HSGF208	Bearing flange	2
5	BRGYAR208-2F	bearing	2
6	12845	pin	2
7	15396	Bed ram	1
8	12840 RH	Mount bracket RH	1
9	WHLA11.5/80-12	11.5/80-12 Wheel assembly	2
-	(Optional) WHLA400X15.5-146T	Wheel Assy 400/60 X 15.5 - 6 Stud, 14 Ply, Traction	2
10	12840 LH	Mount bracket LH	1
11	Mudguard-saddle	Mudguard bracket	8
12	60939b	Mudguard	2
13	127-2550	50mm 6 stud hub with locator hole	2
14	15127	Lift ram	1
15	12843	pin	1
16	12842	pin	1
17	61527	RS2 valve block	1
18	45656	RS2 6 port diverter valve	1
19	15129	Indicator rod	1
20	48015	jack	1
21	15565	Jack mount	1
22	14575	Clevis swivel tow hitch	1
23	4800315	Hose Holder	1
24	15639	Rod cover	1

Loading Mechanism – Machines Built Pre February 2026

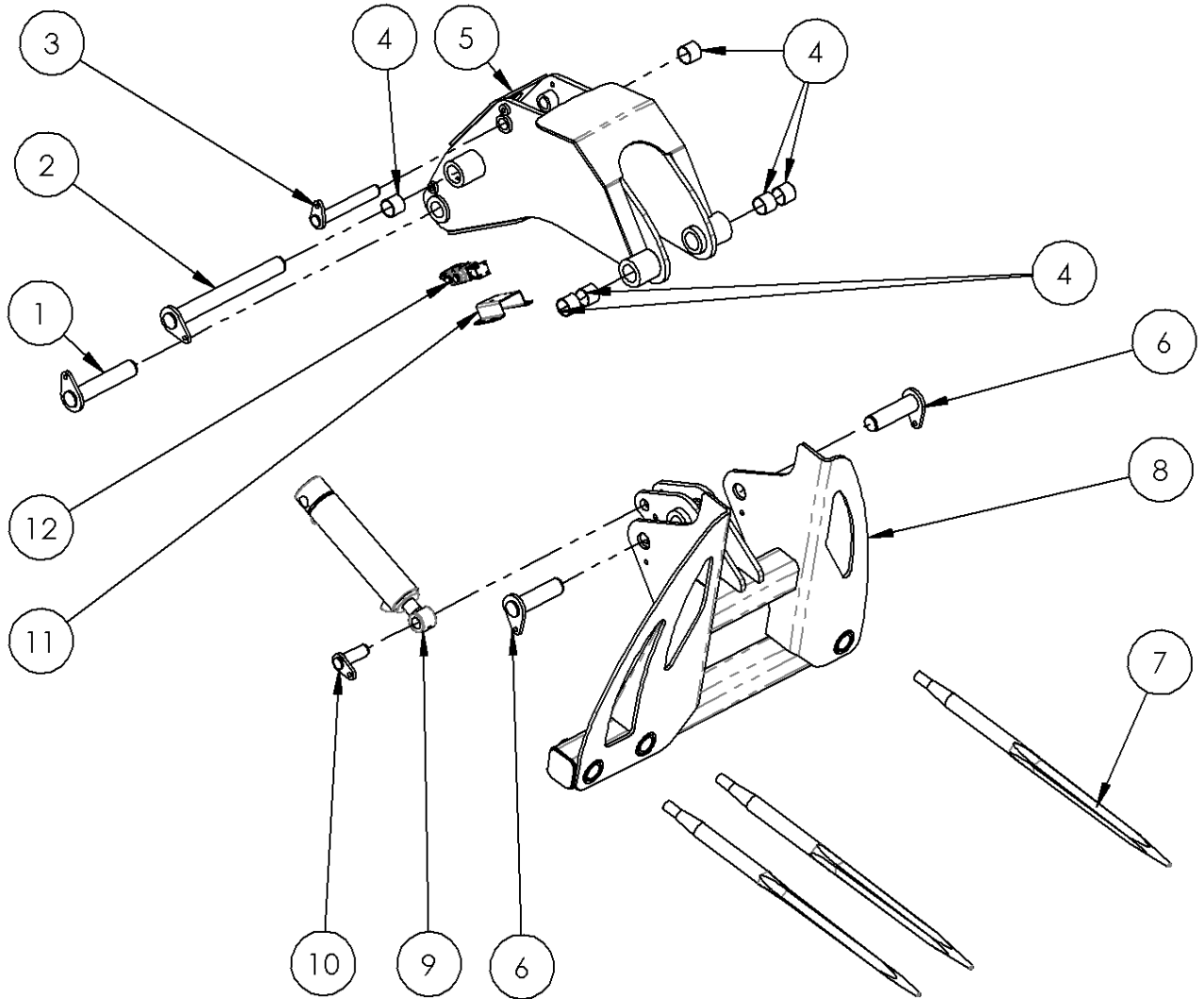

Item	Part Number	Description	Quantity
1	12843	pin	1
2	12844	pin	1
3	12846	pin	1
4	EZX04505040	bush	6
5	13259	Boom	1
6	12848	pin	2
7	43169	spear	3
8	13258	Headstock	1
9	RAM3X1.5X270	Crowd ram	1
10	12847	pin	1
11	13259-10	Float valve mount	1
12	45656-2	3 Port Boom stop valve	1

Loading Mechanism – Machines Built February 2026 Onwards

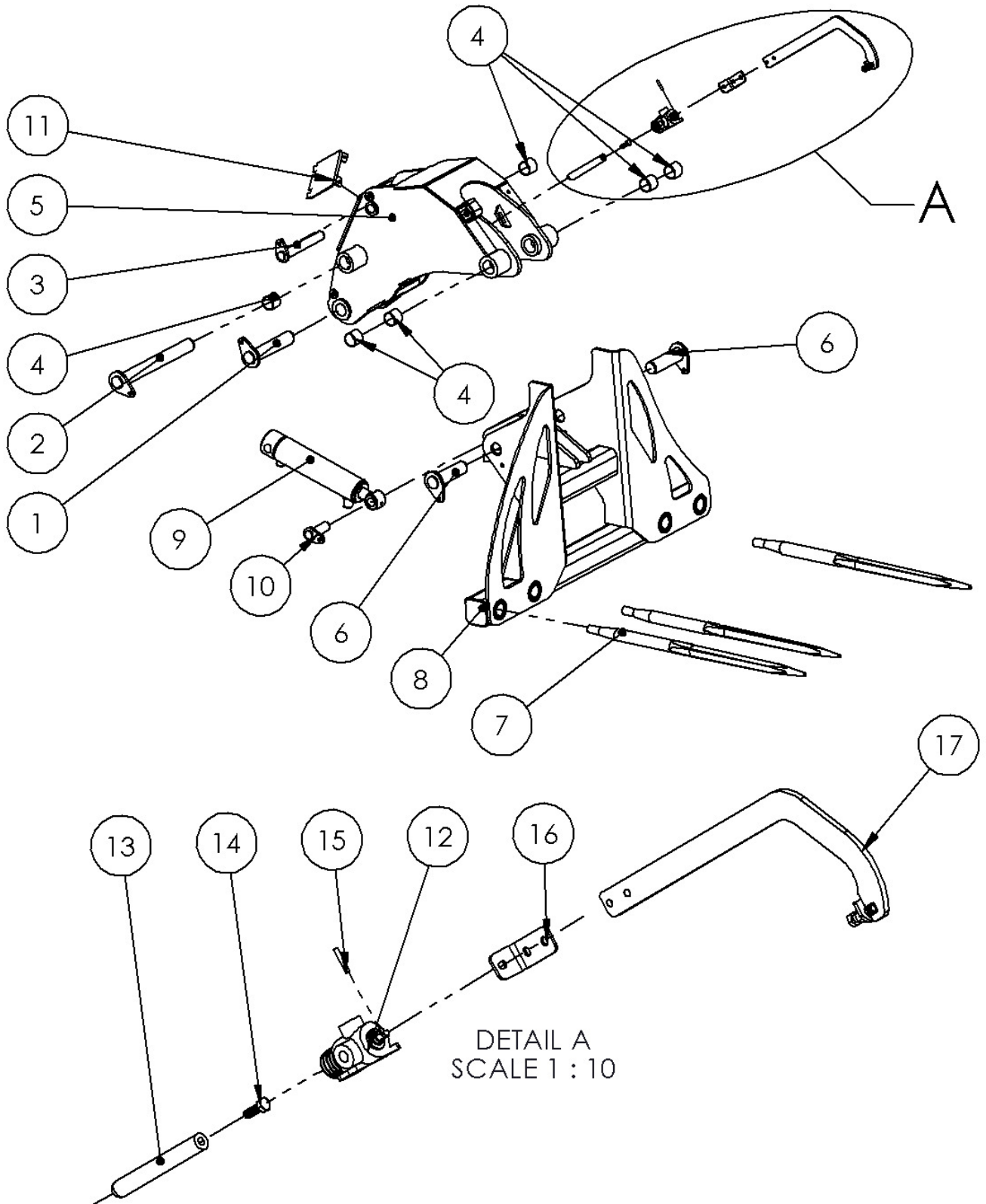

Item	Part Number	Description	Quantity
1	12843	pin	1
2	12844	pin	1
3	12846	pin	1
4	EZX04505040	bush	6
5	15126	Boom	1
6	12848	pin	2
7	43169	spear	3
8	13258	Headstock	1
9	RAM3X1.5X270	Crowd ram	1
10	12847	pin	1
11	15173	Cover	1
12	127-2635	Float Valve	1
13	15390	Actuation Rod	1
14	Bolt	M12x35	1
15	RP6.35x38	Roll pin 1/4" x 1/2"	1
16	15146-2	Lever Bracket	1
17	15392	Lever weldment	1

String Bin Assembly – Machines Built Pre February 2026

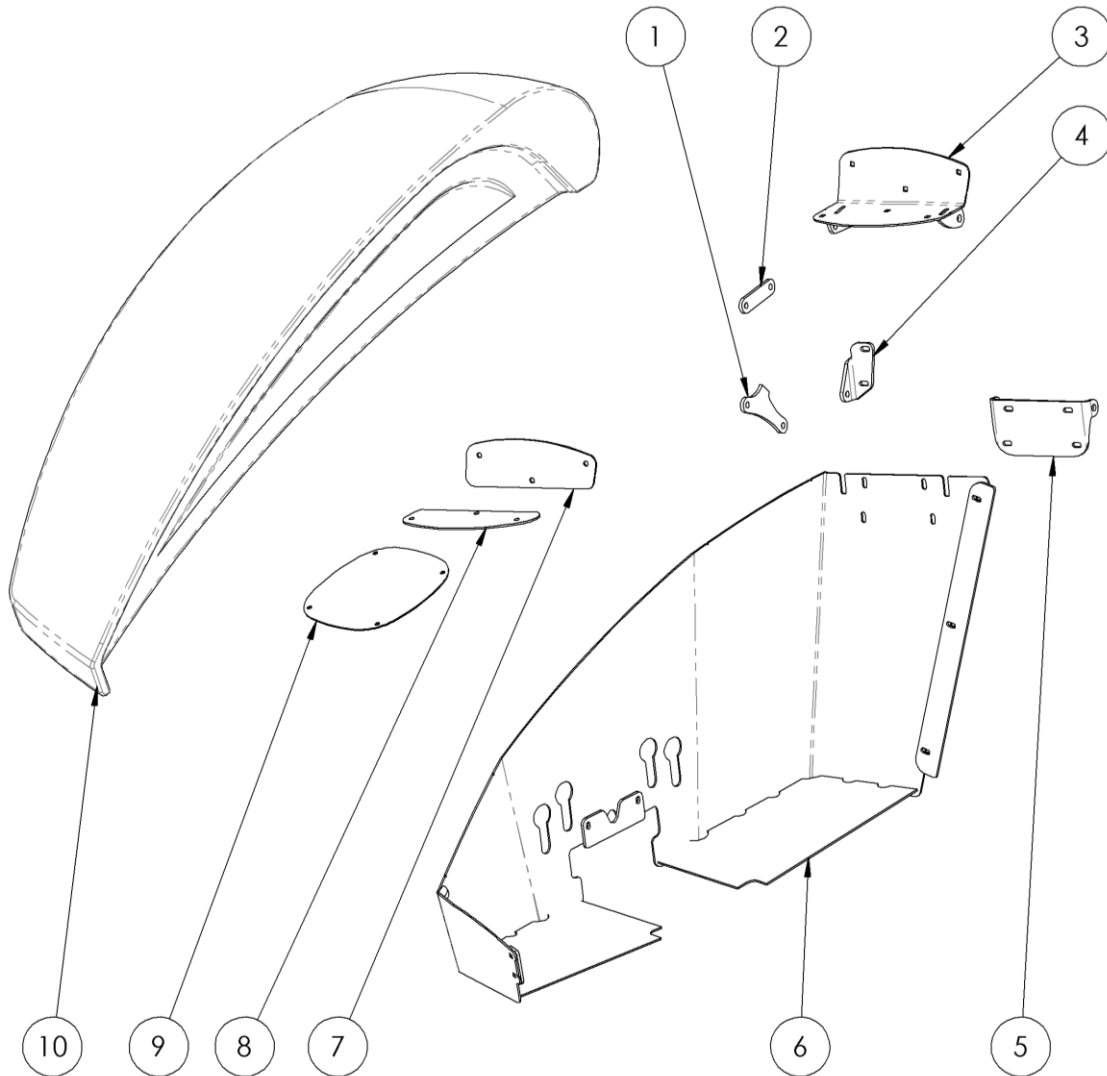

Item	Part Number	Description	Quantity
1	13253-6	Stop plate	1
2	13253-7	Stop link	1
3	13255	Upper hinge mount	1
4	13253-5	Stop mount	1
5	13253-1	Lower hinge	1
6	13252	String bin	1
7	13253-3	Vertical inner reinforcer	1
8	13253-4	Horizontal inner reinforcer	1
9	13253-2	Access hole cover	1
10	13254	String bin lid	1

String Bin Assembly – Machines Built February 2026 Onwards

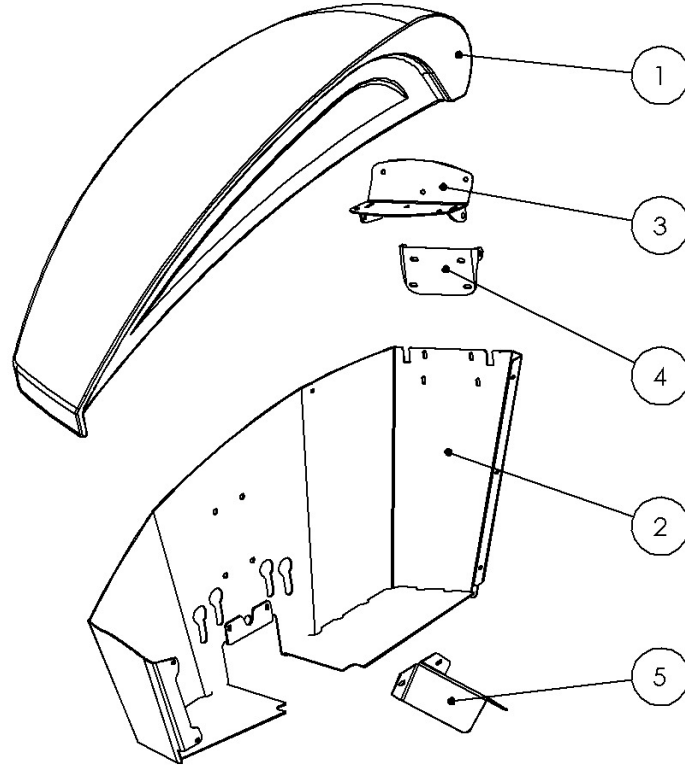

Item	Part Number	Description	Quantity
1	13254	String bin lid	1
2	15131-1	String Bin	1
3	13255	Upper hinge mount	1
4	13253-1	Lower hinge	1
5	15639	Rod Cover	1

50mm 6 Stud Hub Monroc

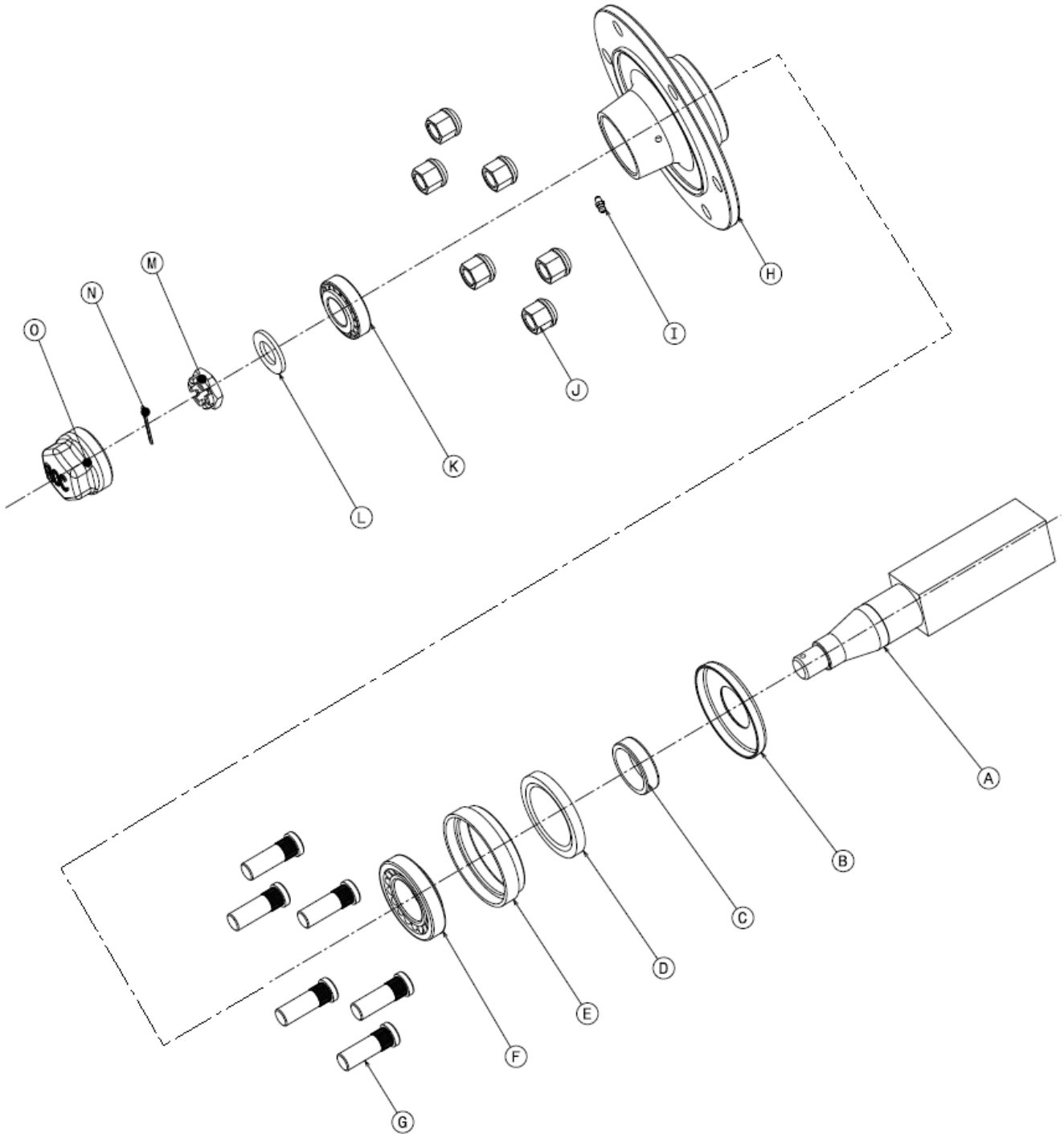

50mm 6 Stud Hub Monroc

Item	Code	Description	Quantity
A	479555Q010-L	Body Stub Axle Square 50 01	1
B	3512004000	Washer – 45x96x2	1
C	416701Q00A	Ring seal contact 45x55x14.5	1
D	339101Q002	Seal AS NBR 55x88x10	1
E	416700Q00A	Ring seal support 93x88	1
F	30209	Bearing 30209	1
G	3351008000	Stud M18x50	6
H	412905Q000	Hub 506A ROV	1
I	3371001000	Grease nipple – M6 (optional)	1
J	3314007000	Wheel nut M18 x 50	6
K	30206	Bearing 30206	1
L	3513002000	Washer – 25x45x4	1
M	3302003000	Nut – HK – M24x2	1
N	3362004000	Pin – 4X40	1
O	3241003000	Cup – M63x150	1

50mm 6 Stud Hub ADR

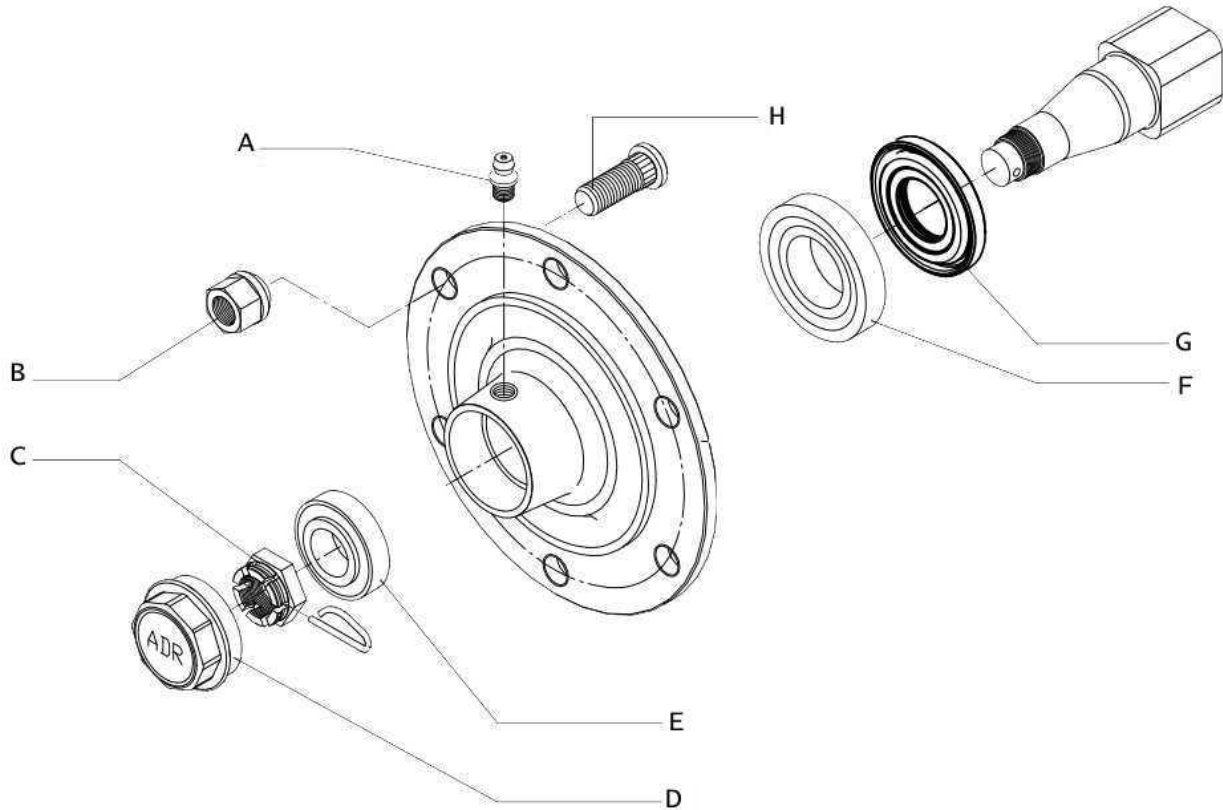

Item	Part Number	Description	Quantity
A	GRN8-45x1.25	M8 grease nipple	1
B	110-0917	M18 Wheel nut	6
C	110-1018	Crown nut M27x1.5 + spring pin	1
D	110-0843	Hub cap 62mm	1
E	BRG30206J2	Bearing 30206 ext dia 62mm int dia 30mm	1
F	BRG30209J2	Bearing 30209 ext dia 85mm int dia 45mm	1
G	110-0192	Seal ext dia 85mm int dia 45mm	1
H	110-0945	Stud M18x1.5	6

Notes: