

# Owners Manual

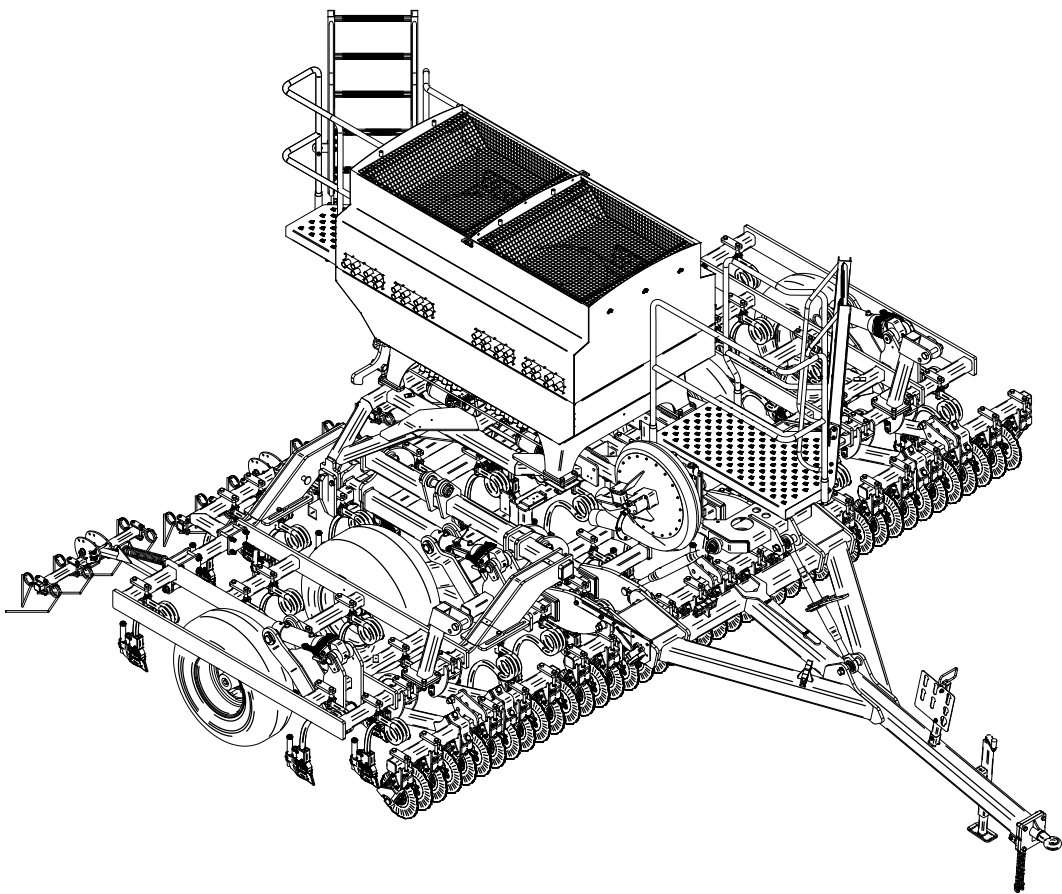

## Renovator AS5300 5",6",7" ORIGINAL INSTRUCTIONS



*Built to work.*

**Head Office:**  
P.O. Box 2018  
Hilton Highway, Washdyke  
Timaru, New Zealand  
Telephone (03) 688 2029  
Facsimile (03) 688 2821

**Australian Branch:**  
Building 2 107-117 Boundary  
Road  
Laverton North, Melbourne,  
Victoria 3026 Australia  
Telephone (03) 9369-6548  
Facsimile (03) 9314-6810

**Pt. No. 67449  
Issue 1020**



# Renovator AS5300 Contents

	Page
<b>Introduction</b> .....	2
<b>Acquisition &amp; Warranty</b> .....	2
<b>Disclaimer</b> .....	2
<b>Description of Machine</b> Working Principle .....	3
<b>Specification</b> Dimensions & Capacities .....	4, 5
<b>SAFETY - General</b> Safety Symbols on Machine .....	6
Operator Safety .....	7
Be Prepared for Emergencies .....	7
Appropriate Dress .....	8
Transport This Machine Safely .....	8
Handle Agricultural Chemicals Safely .....	9
Avoid High Pressure Fluids .....	9
Safe Work Practices .....	9
Practice Safe Maintenance .....	10
<b>SAFETY - Machine Specific</b> Hazard Points .....	11
Safety Decals & Safety Guards .....	13
<b>Transport</b> .....	15
<b>Setup, Calibration &amp; Operating Procedure</b> General Operation .....	16
Setting Depth .....	17
Read Before Operation .....	18
Pre-Calibration Setup .....	26
Calibration .....	28
Sowing Chart -NORMAL seed .....	32
Sowing Chart -FINE seed .....	33
Airflow & Fan Speed .....	34
Blank Page for your Calibration Notes .....	35
<b>Maintenance &amp; Care</b> General .....	36
Lubrication Instructions .....	37
Maintenance Schedule .....	38
Storage .....	39
ISOCAN ISOBUS Alarm Codes .....	40
<b>Parts List</b> Disc Opener Parts .....	46
Tine & Boot Parts .....	48
Tine Harrow Parts .....	50
Bushes - Mainframe Wheels .....	52
Bushes - Wing Wheels .....	54
Bushes - Wing Pivot .....	56
Lift/Lower Rams .....	58

# Introduction

## Acquisition & Warranty

On delivery of your new Duncan Renovator AS5300 please check that the machine is not damaged. In cases of shipping damage, please ask your dealer to arrange for the appropriate claim to be lodged immediately. Assemble any parts supplied loose and inspect your machine with the aid of this manual to familiarise yourself with its features. If you have any queries ask your dealer straight away. The machine is covered by our 12 month warranty on faulty parts, subject to normal use.

**Record below the serial number of your machine and keep it in a secure place to help trace the machine and assist us when you order parts.**

## The Owner's Manual

**Model:** .....

**Serial No:** .....

**Owner:** .....

.....

.....

**Delivery Date:** .....

**Dealer:** .....

.....

.....

Your new Duncan Renovator AS5300 will give long and efficient service if given normal care and operated properly.

This owner's manual is provided so that you can become thoroughly familiar with the design of the machine and to furnish information on correct operation, adjustment and maintenance. **Only persons well acquainted with these guidelines should be allowed to use the equipment.**

A separate illustrated parts section has been provided so that if any parts are required your dealer will be able to supply them by reference to part numbers.

The manual is considered as part of your machine and must remain with the machine when it is sold.

**Right and left hand references in this manual are determined by standing behind the machine and facing in the direction of travel.**



This Document contains the Original Operating Instructions for this machine and are verified by the Manufacturer.

Signed:.....

Product Development Manager

### Disclaimer

Every effort has been made to ensure that the information in this manual was accurate and up to date at the time of going to press. Clough Agriculture reserves the right to make subsequent changes to the machine, where necessary, without notification.

The Company will not be responsible for any damage or consequential loss arising out of misinterpretation or failure to follow recommended procedures. Nor will it be liable for any damage caused by or arising out of modification or misuse of its product.

**The owner has a responsibility to protect himself and others by observing all safety information and by ensuring all operators are well acquainted with the safety information, trained in the correct use of the machine and applying safe work practices.**



## Description of Machine

The Duncan 'Renovator AS5300' is a Coil Tine T-boot drill and is fitted with disc openers.

The large split hopper is mounted on a robust centre frame.

Sowing depth is hydraulically controlled. The quality European air metering units handle all seeds from turnip and rape through to peas and maize and permits easy calibration. The seeders are driven via a radar ground speed proportional electric drive system. Seeding ceases automatically when the machine is raised into the transport position.

The wings may be hydraulically folded up for legal transport width.

## Working Principle

The air flow, metering units and electric drive system are easily set to give the desired sowing and/or fertilizer rate. The front disc precuts the ground surface followed by the coil tine and T-boot which creates the seed bed. Air delivers seed down the flexible tubes between the seeder and tee-boot units and drops into the prepared seed bed.

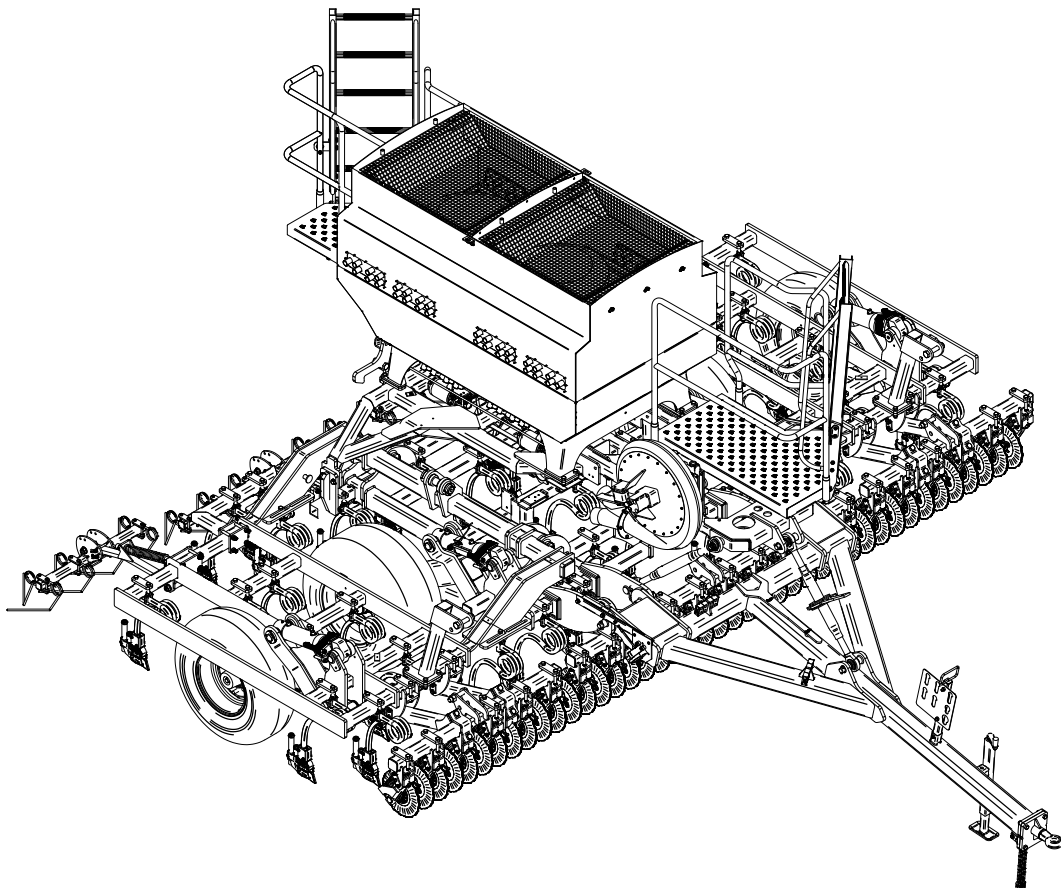

# 'Renovator AS5300' Dimensions & Capacities

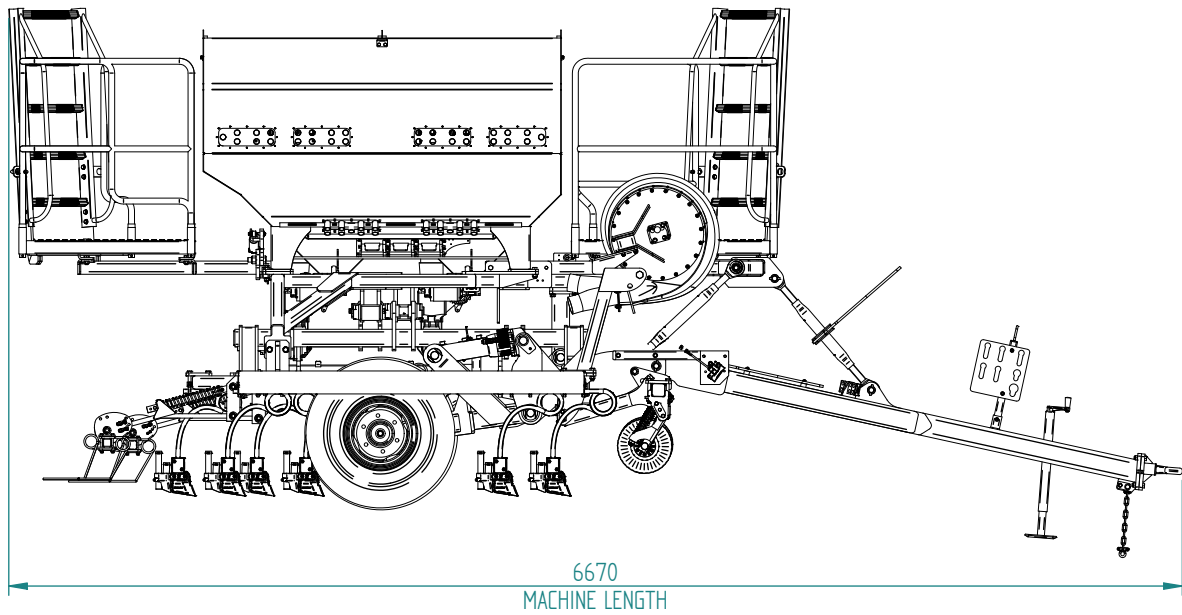

Dimensions & Capacities	42 Run	36 Run	30 Run
Description	5.3m 5 inch	5.3m 6 inch	5.3m 7 inch
Width (over wheels /mm)	3100		
Working Height (mm)	2790		
Transport Height (mm)	3110		
Machine Length (mm)	6670		
Row Spacing (mm)	125	147.5	175
Sowing Width -effective (mm)	5250	5310	5250
Box Capacity per bin	1000 litres		
Main Tyre Size & Inflation Pressure	19/45-17 W154 18 ply (65psi, 4.5bar)		
Wing Tyre Size & Inflation Pressure	11.5/80-15.3 14 ply (70psi, 4.75 bar)		

# 'Renovator AS5300' Dimensions & Capacities

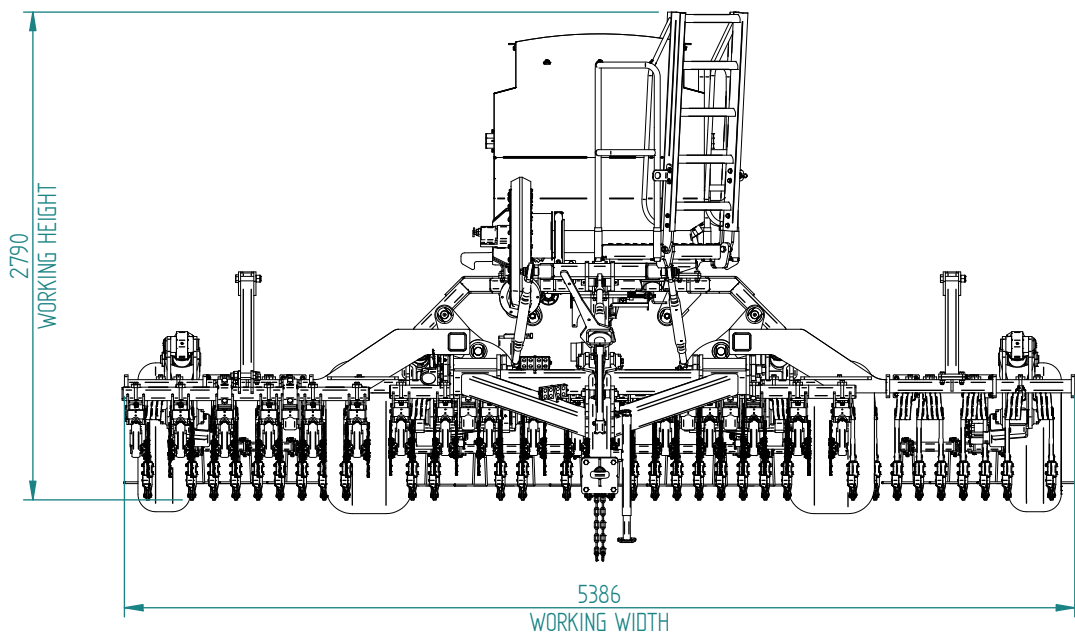
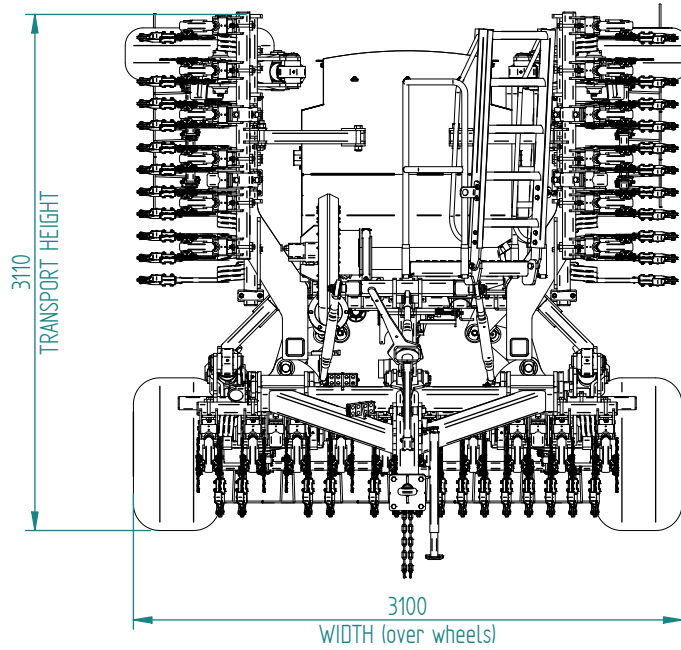

# 'Renovator AS5300' Safety



## ATTENTION

On the machine important safety information is indicated by these symbols. These highlight general safety aspects in regard to the machine rather than specific hazards.



**Do not ride or allow passengers on the machine.**

Under no circumstances are passengers to be permitted on the machine while it is in operation or being transported. Any footboards and/or footsteps are provided solely for the purpose of preparing the machine for use.



**Keep clothing and body extremities well clear of pinch points while the machine is operating (seeding or calibrating). Keep well clear of moving parts at all times.**

These signs typically occur wherever trapping points exist. These include drive chains, sprockets, shafts, wheels, discs, pivot points, etc. Guards are provided with the machine for safety reasons (where practical without compromising machine performance). Ensure these are always fitted during operation.



**Always exercise extreme caution in the vicinity of sharp edges and points.**

Where possible guards are provided with the machine for safety reasons (where practical without compromising machine performance). Ensure these are always fitted during operation.



**Footboards, footsteps, drawbars and other machine surfaces may be slippery when wet.**

Apply extra caution in wet conditions and in the early morning when surfaces are wet.

**KEEP CLEAR**

**Keep Clear. (It is dangerous to be in this area when the machine is operating.)**



# 'Renovator AS5300' Safety

## SAFETY - General

**N.B. Throughout this manual important safety information is indicated by these symbols in the margin:**



**NO RIDE**

A **prohibition** should be observed under all circumstances.



**WARNING**

A **warning** indicates a hazard that could cause death or injury if the warning is ignored.



**CAUTION**

A **caution** indicates a hazard that may cause damage to property if the caution is ignored.

This section of the manual offers general guidelines for the safe operation of machinery. It does not replace local safety regulations. These guidelines were current at the time of publication, but may be superseded by later regulations.

Clough Agriculture has made every effort to highlight all risks to personnel or property. Owners and operators have a responsibility to exercise care and safe work practices at all times in the vicinity of the machine.

Owners are advised to keep up to date on safety issues and to communicate these to all users of the machine.

Contact the Occupational Safety and Health Service (OSH) for further information about general safety aspects. If you have safety concerns specifically related to this machine, contact your dealer immediately.

### Operator Safety

Read this manual carefully before operating new equipment. Learn how to use this machine safely. Be thoroughly familiar with the controls and the proper use of the equipment before using it.



**WARNING**

Take careful note of all safety instructions both in this manual and on the machine itself. Failure to comply with instructions could result in personal injury and/or damage to the machine.

Replace missing or damaged safety signs on the machine and ensure that these remain clearly visible.

**It is the owner's responsibility to ensure that anyone who operates, adjusts, lubricates, maintains, cleans or uses the machine in any way has had suitable instruction and is familiar with the information in this manual (particularly with regard to safety aspects).**

**Operators and other users of the machine should be aware of potential hazards and operating limitations.**



### Be Prepared for Emergencies

Keep a first aid kit and fire extinguisher handy.

Keep emergency numbers for doctors, ambulance, hospital and fire department near your telephone.



**WARNING**

# 'Renovator AS5300' Safety

## SAFETY - General (Continued)



### Appropriate Dress

Wear close fitting clothing and avoid rings or other forms of jewellery which could become caught in the machinery.

People with long hair must have it securely fixed and confined close to the head.

Refer to local safety standards for protective clothing and recommended safety equipment.

Adequate protection, such as a face mask, should be worn if operating this machine in dry and dusty conditions.



### Transport This Machine Safely

Ensure that all linkage pins and security clips are fitted correctly. With trailing machines tow with the drawbar only, as this is the only safe towing point on the machine.

Always check that bystanders (especially children) are well clear (front and rear) before starting and moving the tractor and the machine.

Plan safe routes of travel, and be aware of power lines and other roadside hazards. Take particular care when towing implements on hillsides.

### Do not ride or allow passengers on the machine.

This machine is not designed to carry passengers, and no riders are permitted.



### Road transport

On public roads,

- A speed of 40km/h must not be exceeded.
- Do not operate during the hours of darkness unless standard lights are fitted and clearly visible. (This also applies when visibility is limited, e.g., in foggy conditions.)

See the guidelines in the *Vehicle Dimensions and Mass Rule*, issued by the Land & Transport Safety Authority.

### Avoid tip-overs

Avoid holes, ditches and obstructions which may cause the machine to tip over, especially on hillsides. Never drive near the edge of a gully or steep embankment - it might cave in. Slow down for hillsides, rough ground and sharp turns.



# 'Renovator AS5300' Safety

## SAFETY - General (Continued)

### Handle Agricultural Chemicals Safely

All farm chemicals should be stored, used, handled and disposed of safely and in accordance with the supplier's/manufacturer's recommendations.



**Read the product label before using, noting any warnings or special cautions, including any protective clothing or equipment that may be required, ie. respirator.**

Do not eat or smoke while handling sprays, fertilisers, coated seeds, etc. Afterwards, always wash your hands and face before you eat, drink, smoke, or use the toilet.



Store sprays, fertilisers, coated seeds, etc. out of reach of children and pets, and away from food and animal feeds.

Any symptoms of illness during or after using chemicals should be treated according to the supplier's/manufacturer's recommendations. If severe, **call a physician or get the patient to hospital immediately.** Keep the container and/or label for reference.

### Avoid High Pressure Fluids

Avoid any contact with fluids leaking under pressure, because the fluids can penetrate the skin surface.



Any fluid which penetrates the skin, will need to be **removed immediately by a medical expert.** Seek specialist advice on this type of injury.

Relieve the pressure before disconnecting any hydraulic or other lines. Make all repairs and tighten all fittings before re-connection to pressurised fluid.

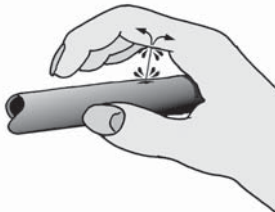

Keep your hands and body away from any pinholes or high pressure jets. Search for leaks with a piece of cardboard instead of using your hand directly.

### Safe Work Practices

All farm machinery is potentially dangerous and should be treated with caution and respect.

Before starting the machine, ensure that all controls are placed in neutral and that bystanders are well clear. Check that the guards have been securely fitted and that any adjustments have been made correctly.



Where possible, disconnect or isolate the drive mechanism to the implement. Lower the machine onto the ground when not in use.

Do not operate this equipment when severe weather conditions appear imminent.

# 'Renovator AS5300' Safety

## SAFETY - General (Continued)



### Practice Safe Maintenance

Keep the machine in safe working condition. Routine maintenance and regular servicing will help reduce risks and prolong the life of the machine.

### General Maintenance

Accidents occur most frequently during servicing and repair. The following general rules must be followed when maintaining or working with machinery:

- All operating and maintenance manuals must be read before and referred to while using or servicing any piece of equipment.
- Turn off all machinery power sources and isolate the machine before making adjustments, doing lubrication, repairs or any other maintenance on the machine.
- Ensure that the machine hydraulics are disconnected from the power source.
- Wear gloves when handling components with cutting edges, such as any ground cutting components.
- Beware of hazards created by springs under tension or compression when dismantling or maintaining the machine.
- It is recommended that you clean the machine with a water blaster or similar apparatus before commencing maintenance.

### Make Sure the Machine is Well Supported

When machinery is fitted with hydraulics, do not rely on the hydraulics to support the machine. During maintenance or while making adjustments under the machine, always lock the hydraulics and support the machine securely. Place blocks or other stable supports under elevated parts before working on these.



### Electrical Maintenance

Disconnect the electrical supply from the tractor before doing any electrical maintenance.



### Welding

With electronic equipment in modern tractors it is advisable to disconnect the machine from the tractor, or at least disconnect the alternator and battery before attempting any welding.



### Use Only Genuine Spare Parts

Unauthorised modifications or non-genuine spare parts may be hazardous and impair the safe operation and working life of the machine.

Excess lubricants must be disposed of safely so as not to become a hazard.

# 'Renovator AS5300' Safety

## SAFETY - Machine Specific

This section of the manual gives specific guidelines for the safe operation of the Renovator AS5300.

These guidelines were current at the time of publication, but may be superseded by later circumstances. They do not necessarily cover every possible hazard and must be read in conjunction with the **SAFETY - General** section (Page 7 to 10).

### Hazard Points on the Renovator AS5300

The lists below are not all-inclusive and serve only to highlight the more obvious areas of risk.



The decals attached to the machine are a general reminder that there are hazardous areas on the machine, rather than specifically highlighting all possible hazards.

**For decal locations on machine, refer Page 13.**



#### No Ride

Passengers are not permitted anywhere on the machine.



#### Pinch Points/Moving Parts

Hazardous areas include:

- Front Tractor Linkage
- Fan Unit
- Front Disc openers
- Wings
- Electric Drive units
- Roller
- Wheel legs and main frame assemblies
- Finger tine assemblies (where fitted).



**Slippery  
When  
Wet**

#### Slippery When Wet

Hazardous areas include:

- Footboards and footstep.
- All smooth surfaces on the frame structure.

**KEEP CLEAR**

#### Keep Clear

Hazardous areas include:

- Between the tractor and Renovator AS5300.
- Immediately adjacent to the Renovator AS5300 side.

# 'Renovator AS5300' Seed Drill Safety

## SAFETY - Machine Specific (Continued)



### Hazard Points on the Renovator AS5300 (Continued)

For guard locations on machine, refer Page 13.



### Transport

The two wheels located at the rear of the machine are for the purpose of controlling sowing depth. These are also used to support the machine weight.

**Important** - Refer to safety cautions in the **Transport** section, page 15 of the manual. Ensure that all linkage pins and security clips are fitted correctly.

### Maintenance

Refer Page 34 for reference to the **Maintenance and Care** section of the manual.

### Lubrication

Refer Page 34 for reference to the **Maintenance and Care** section of the manual.

# 'Renovator AS5300' Seed Drill Safety

## SAFETY - Machine Specific (Continued)

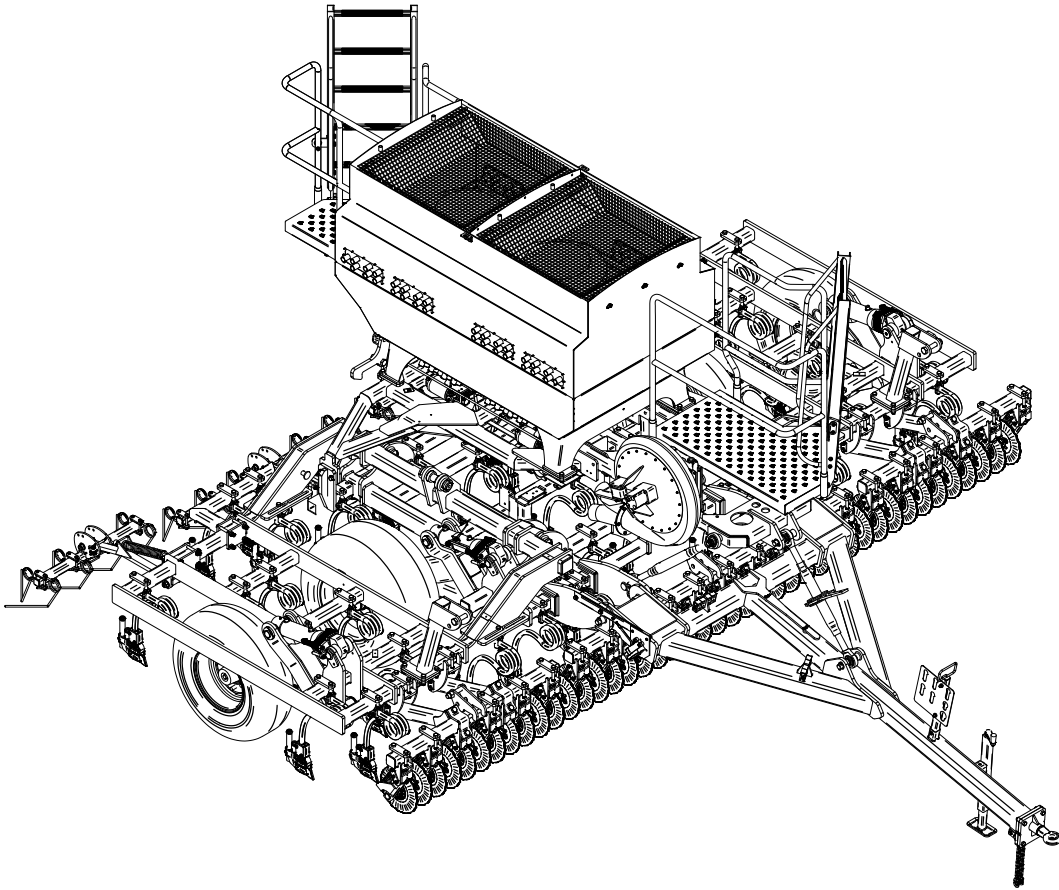

Item	Decal/Guard	Pt. No.
1	'No Ride'	43900
2	'Pinch Point/Moving Parts'	43901
3	'Slippery When Wet'	43902
4	'Keep Clear'	43904
5	'40 km/hr'	43912

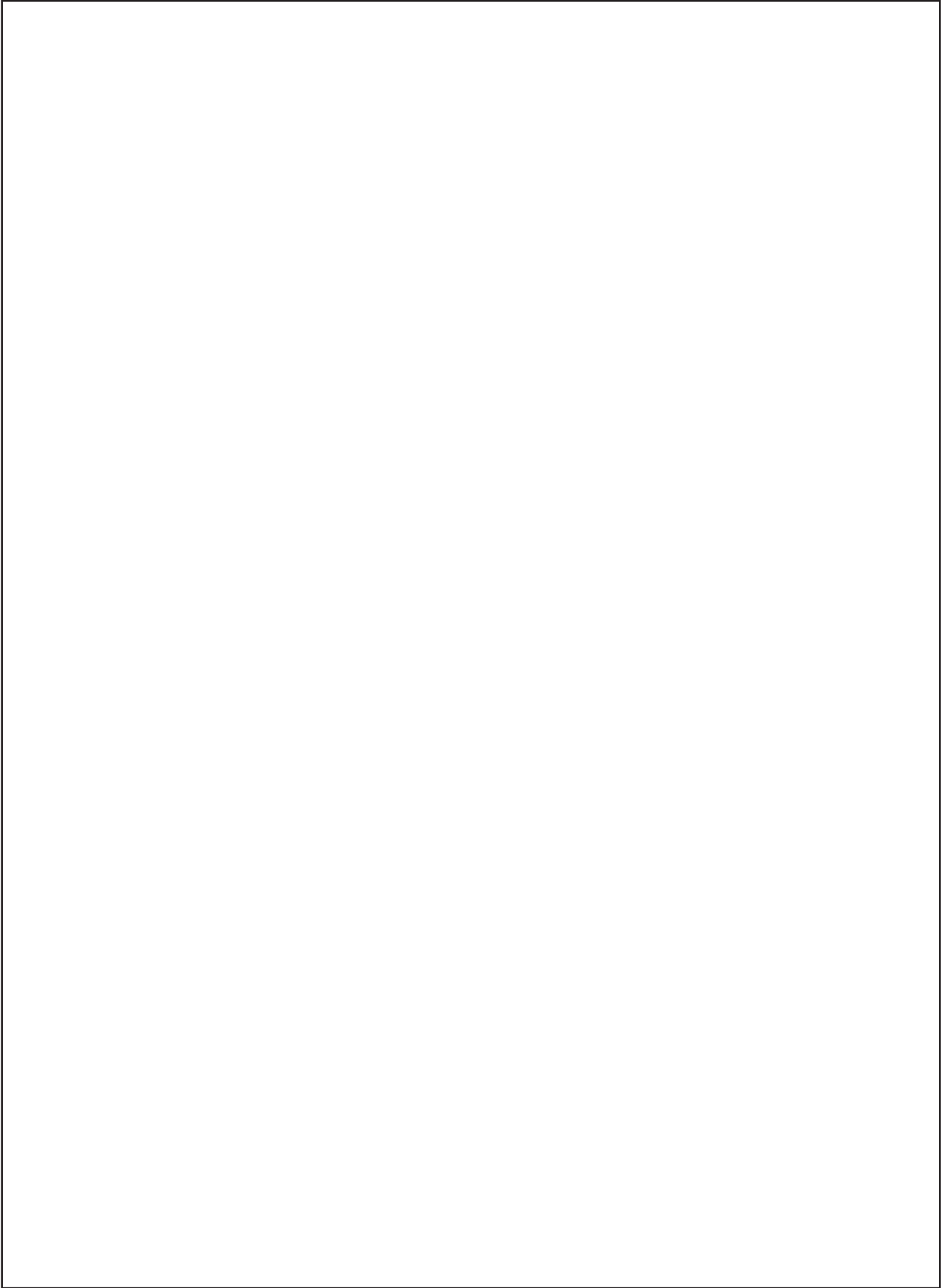



# 'Renovator AS5300' Transport

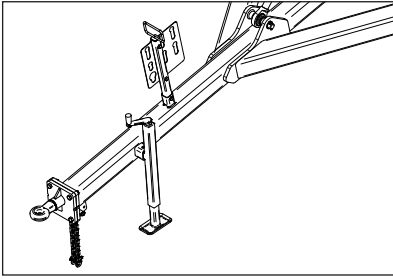

## Transport

- 1 Raise the drill into the transport position.
- 2 **Important** - To avoid machine damage due to drill lowering during transport, always close the hydraulic valve on the drawbar. Move the handle to a position at 90° to the hydraulic line. This applies to the drawbar and disc opener hydraulic valves where fitted.

- 3 Locate jack stand in transport position, if fitted.
- 4 Ensure lighting and oversize warning requirements meet recommendations published by the local Land Transport Authority or equivalent.

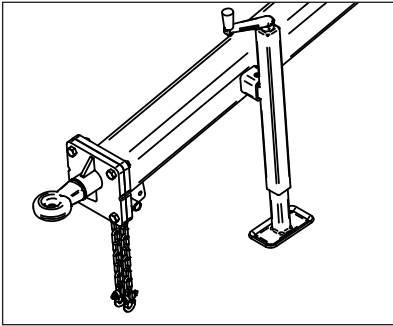

- 5 **Maximum towing speed 40 km/hr.**  
**For countries other than New Zealand other speed restrictions may apply, please refer to your local transport authority.**

Ensure towing vehicle requirements are adequate for the towed vehicle e.g. mass, brakes. Refer to recommendations published by the local Land Transport Authority or equivalent.

Braking when towing can cause the load to jackknife. Use extra care when towing in adverse conditions such as mud, inclines and sharp bends.

Lower towing speeds are recommended on farm roads/tracks and where one wheel is on or over a road verge.



- 6 **Attach safety chains to tractor.**  
Safety chains must be crossed over underneath the coupling and attached to the towing vehicle. The attachment points must be as close as practical to the towing coupling and one each side. The towbar on the towing vehicle must be rated for the towed mass. **Do not remove or replace the safety chains provided with any other type than those supplied.**

**Note:** The safety chains are provided with sufficient length to cater for all towing vehicles. Safety chains must be shortened by cutting off excess length so that if the coupling fails the drawbar will not hit the ground.

- 7 If the machine is fitted with row markers or other vertical extensions, check clearance under power lines en route.



- 8 **Important** - For greater disc opener ground clearance, adjust the ram or turnbuckle on the disc opener unit so they are at maximum height, and/or extend the drawbar ram or turnbuckle to level the machine chassis.

# 'Renovator AS5300' General Operation

## Operation

### General Operation Guidelines



- 1 Hydraulic Fan -connect the hoses in the following order:

First - connect Zero pressure Case Drain 3/8" hose (1/2" BSP Female QR) to hydraulic reservoir \*

Second -connect Motor Return 3/4" hose (3/4" BSP Female QR) to tractor high flow low pressure return port.

Finally - connect High Pressure Motor feed 1/2" hose (1/2" BSP Male QR) to tractor remote.

Disconnect in the reverse order to prevent motor seal damage.

- \*The tractor hydraulic reservoir or free drain connection must have zero backpressure.



- 2 Use a sufficiently powerful tractor which is heavy enough to tow the drill safely.
- 3 Operate the drill at a speed of 6-12 km/hr (4-8 mph).  
In stony and uneven ground conditions a lower speed is more appropriate
- 4 Check that the drill is level during calibration and while seeding.
- 5 Check tyre pressure before seeding. Refer page 5.
- 6 Double check seed rates before seeding.
- 7 Raise the drill out of the ground when making any turns.
- 8 Raise the drill out of the ground before backing up.
- 9 After prolonged storage, check to see that all drive mechanisms and hydraulic equipment are functioning correctly. Check that the seed tubes are not perished or blocked.

### Sowing Speed

Typical travel speeds when sowing range from 6-12 km/hr in good conditions. In stoney and uneven ground conditions a lower speed is recommended to minimise rapid part deterioration. Sowing too fast can result in:

- 1 Poor contour following and uneven sowing depth.
- 2 Impact damage to:
  - a Ground engaging components.
  - b Bearings, housings & axles.
  - c Fasteners & structural components.
- 3 More extreme conditions will result in greater vibration and uneven seed flow at low seeding rates.

# 'Renovator AS5300' General Operation

## Sowing Depth Control

The sowing depth is dependent on:

- 1 The wheel height in relation to the chassis
- 2 Tyre pressure
- 3 Ground condition i.e. hard or soft

The wheel height in relation to the chassis is controlled using the hydraulic ram depth stop. With the machine raised up, adjust the position of the depth stop.

## Transport Position

It is recommended to raise the drill into the transport position when turning at headlands to avoid damage to the ground engaging components.

## Wing Pressure Setting

This is used to keep down pressure onto the wings for even sowing depth across the tool bars: this transfers the centre frame weight to the wings in hard conditions.

The wing hold switch must not be activated when the wings are folded ie when the machine is in transport. The switch may only be activated when in the drilling position.

All conditions are different so the wing pressure can easily be adjusted to the desired setting by using the gauge on the machine. When the switch is activated, the oil in the wing rams is held in this hydraulic circuit under pressure and can't return to the tractor. Expelled oil from the rams is taken up by the accumulator.

When the tractor remote is positioned into the float position it allows oil in the hoses to flow back into the tractor. On heavily undulating ground and in some other conditions a (factory set) safety pressure relief valve is automatically triggered; this protects the machine from damage. When this safety feature is triggered, the wing pressure setting will need to be reset.

### How to set the wing pressure:

1. Position the pressure switch to ON (in-cab console).
2. Using your tractor remote lever, power up the hydraulic system to the desired level using the gauge on the machine as a guide.
3. Move the tractor hydraulics into the float position for this function. -the system is now set.

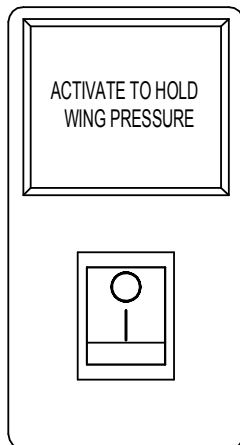

# 'Renovator AS5300' Read Before Operation

## Components Referred to in the Pre-Calibration Setup and Calibration Process

The following pages describe how to set the machine up for calibration, the calibration process and subsequent adjustments to obtain the desired seed and/or fertilizer output.

Terms and words used in those instructions are shown below:-

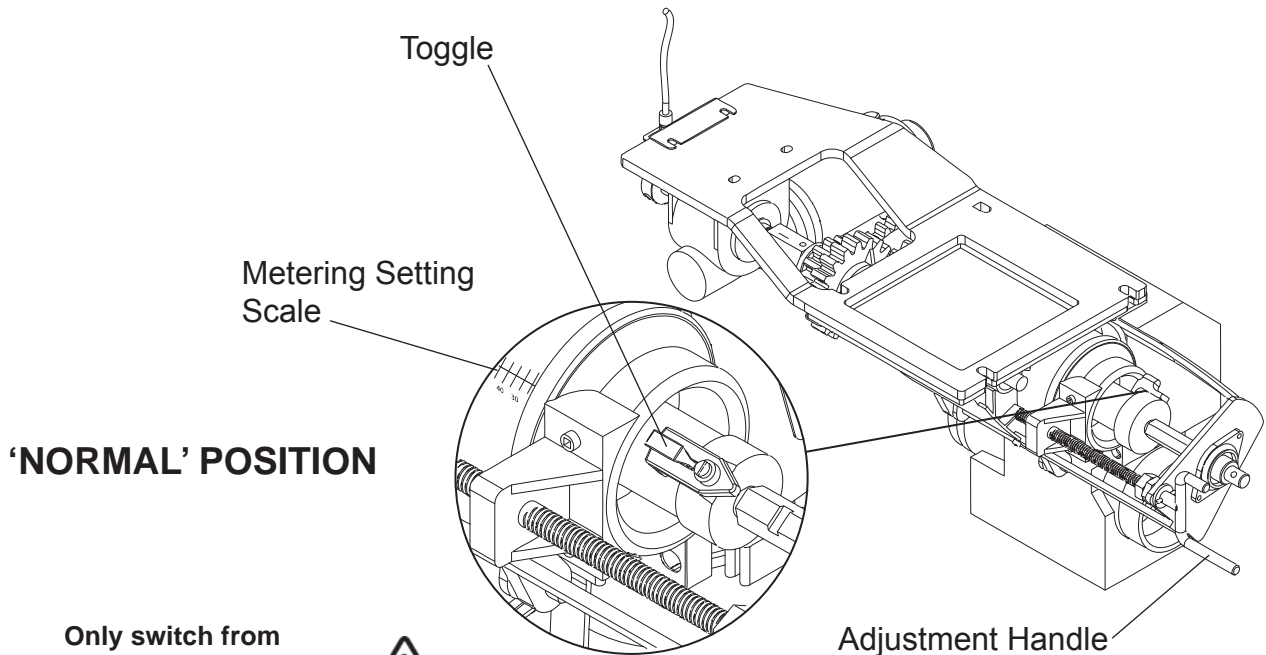

### 'NORMAL' POSITION

Only switch from normal to fine seed if the seed hopper is empty

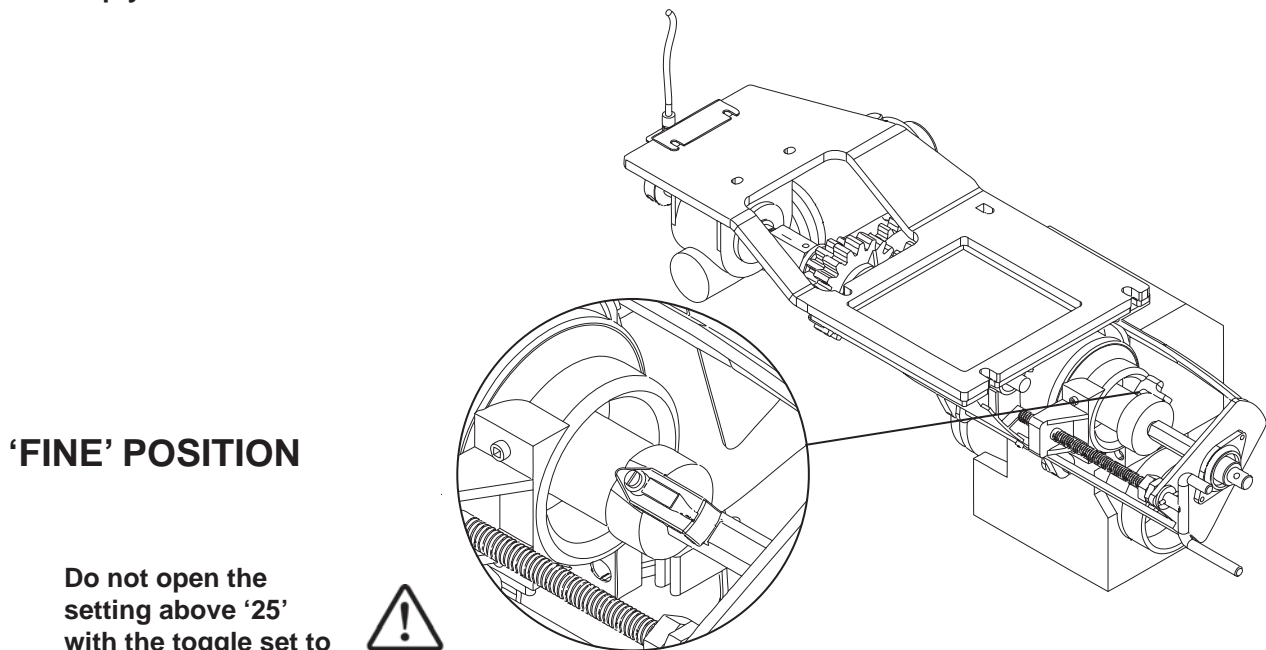

### 'FINE' POSITION

Do not open the setting above '25' with the toggle set to 'fine' as the adjuster will break.



# 'Renovator AS5300' Read Before Operation

## Components Referred to in the Pre-Calibration Setup and Calibration Process

The following pages describe how to set the machine up for calibration, the calibration process and subsequent adjustments to obtain the desired seed and/or fertilizer output.

Terms and words used in those instructions are shown below:-

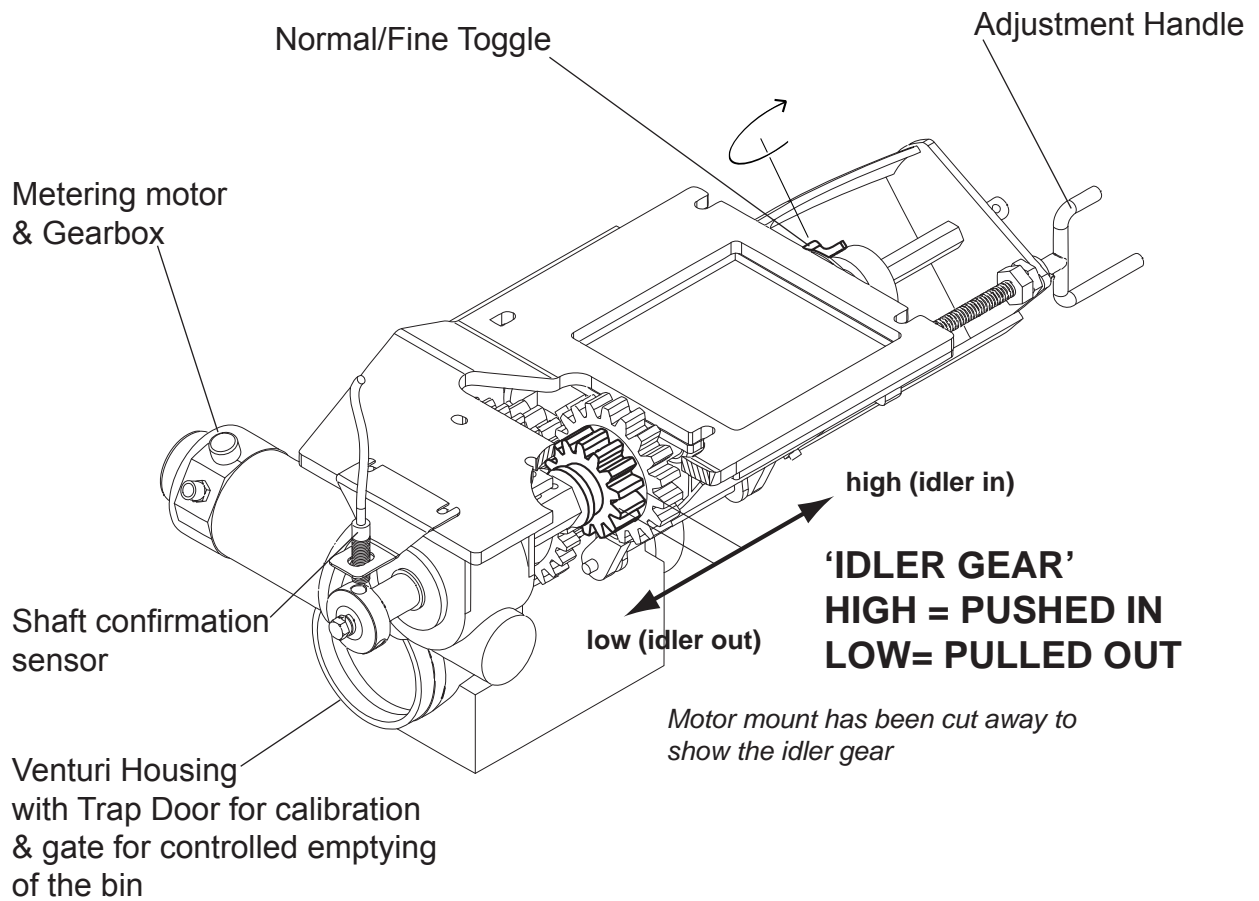

# 'Renovator AS5300' Read Before Operation

## **Components Referred to in the Setup and Calibration Process**

The following pages have been extracted from the RDS/TOPCON ISOBUS/ISOCAN Operator's manual and serve as an introduction to the functions of the Artemis ISOCAN screen. The functions and layout when operating the drill using the tractor's own ISOBUS screen are very similar.

The Section heading numbers are in relation to the RDS/TOPCON Operator's Manual ie Section 3 is for Operation and Section 5 is for Calibration.

The full RDS ISOCAN/ISOBUS manual is provided with the machine however additional copies in electronic pdf form are available. Please contact your nearest Duncan Ag/Giltrap Engineering dealer.

# 'Renovator AS5300' Read Before Operation

## 3.1 Startup

1. Press the rubber endcap on the left-hand side of the ISOCAN to switch it on. After a short period loading the individual apps, the "Dashboard" screen is displayed.

Figure 2 The "Dashboard" screen

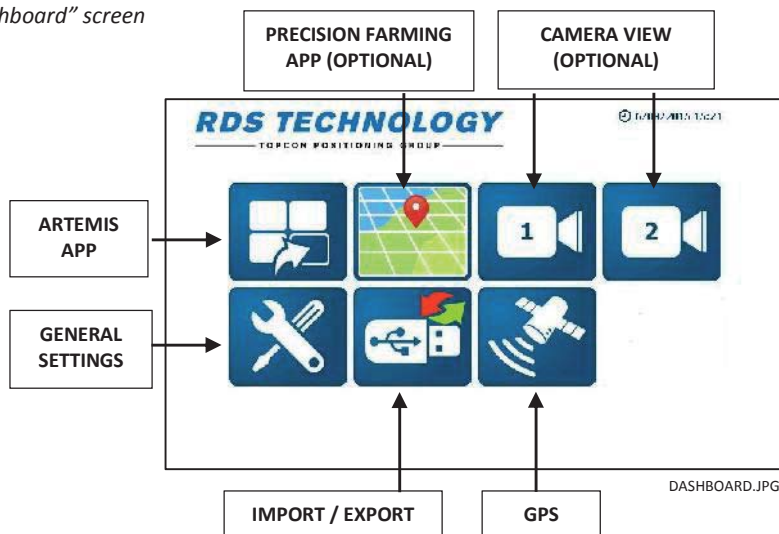

2. Press the  key to go to the Artemis application. On initial startup, the main operating screen is displayed.

## 3.2 Artemis Primary Screen Pages

There are 5 primary screen pages. Press  to cycle between the primary screen pages – Main, Totals, Seed Blockage, Hydraulic Functions (see Note 1) and Settings.

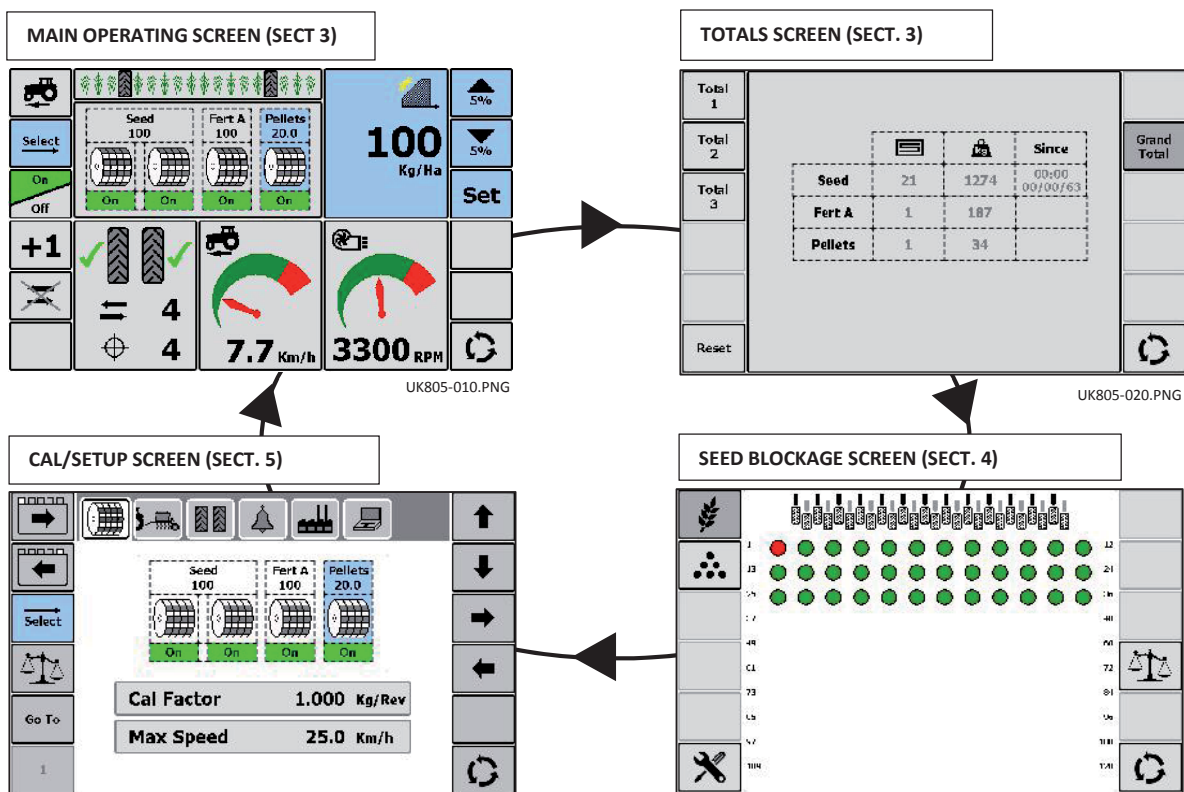

# 'Renovator AS5300' Read Before Operation

NOTE 1: The hydraulic functions screen is specific to particular drills and is not present unless enabled in the "Factory Setup" menu.

Pressing the  key returns to the dashboard. Pressing the  key again, will revert to the primary screen page or sub-menu that was last displayed.

From within the Artemis app and displaying a primary screen page or sub-menu other than the main operating screen, pressing  will return you to the main operating screen.

## 3.3 The Main Operating screen - Summary

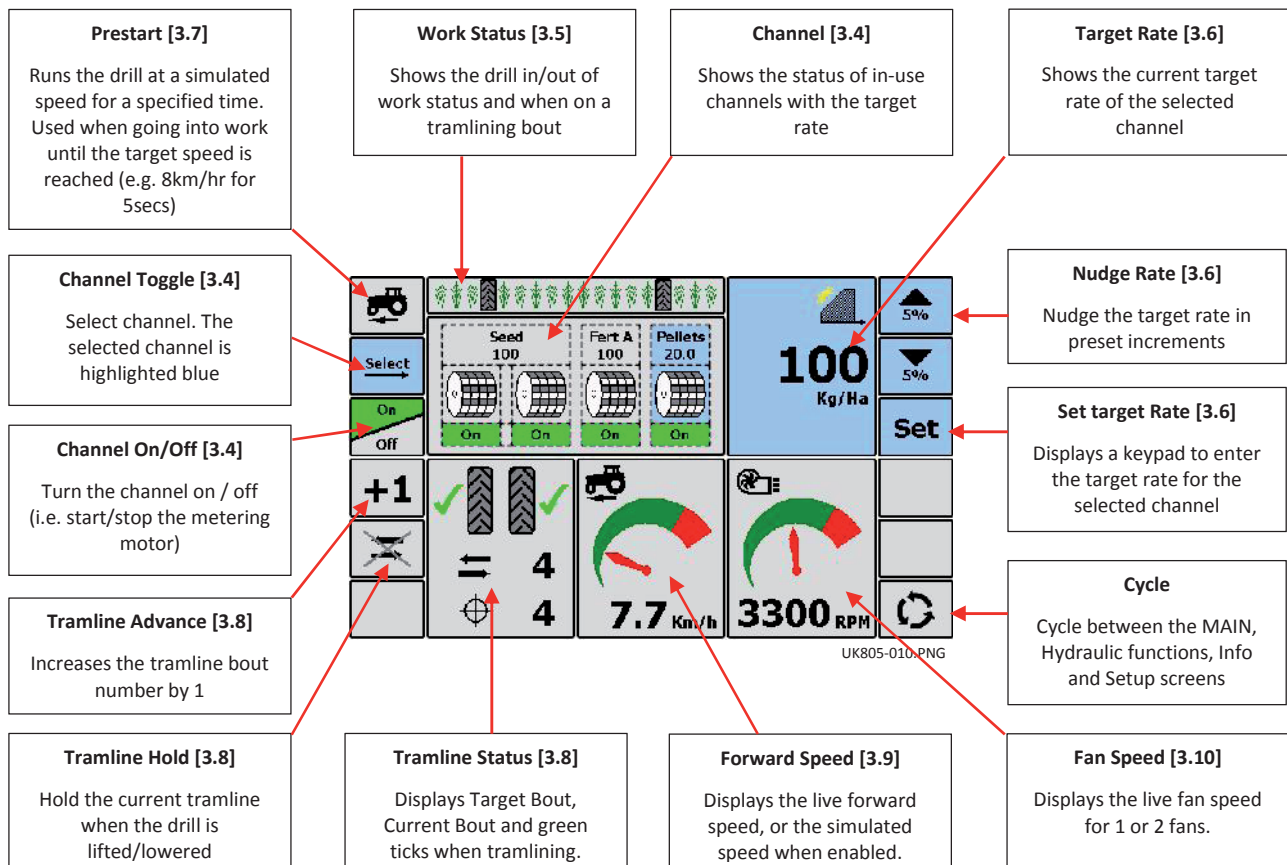

## 3.4 Channel Selection and Status

The currently selected channel is highlighted blue.

Either press , or touch a channel icon to select another channel.

Repeatedly pressing  cycles through the channels.

The channel icon indicates the product and the target application rate.

The target rate can be then set or nudged for the selected channel.

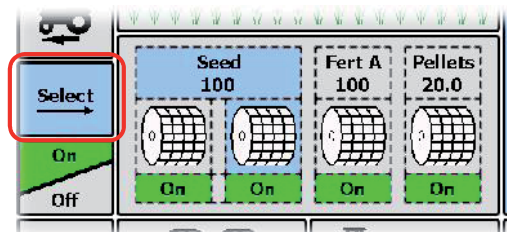



# 'Renovator AS5300' Read Before Operation

The channel icon also indicates the status of the metering motor. The motor speed is proportional to forward speed, and so when the drill is in work, the icon automatically becomes animated as the metering unit starts to turn. It also is animated when you select the Prestart sequence, or if you have a simulated forward speed activated.

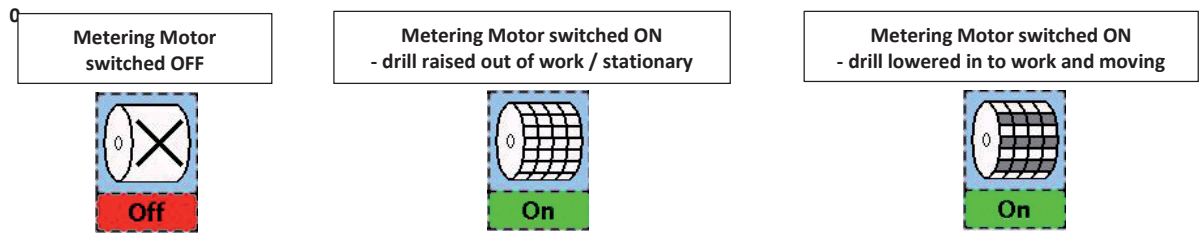

## 3.4.1 Switching Metering motor(s) On-Off / Manual Override / Half-Width Drilling

The metering motor(s) can be stopped manually as desired, eg:

- (i) An area of field needs further cultivation before seeding.
- (ii) In the case of a front-mounted hopper, the metering motor is switched off just before the end of the bout to clear the seed through (the opposite of the 'pre-start function).
- (ii) You want to drill at half-width.

The currently selected channel is highlighted blue.

To switch an individual channel:

Briefly press / to switch the currently selected channel On/Off.

Alternatively, briefly touch a channel icon to switch it On/Off.

To switch all channels:

Press and hold / for 3 seconds.

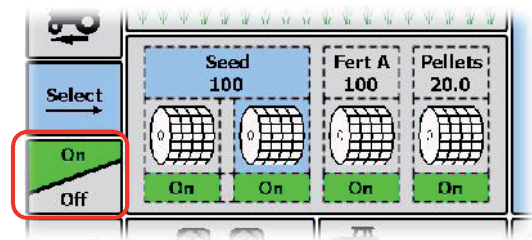

Half-width Drilling:

Applicable for drills configured with 2 linked channels, where normally for full-width drilling the motors are controlled in tandem (indicated by channel icons 1+2 and/or 3+4 being linked across the top as shown).

When half-width application is required, either left or right metering motor may be switched off by briefly touching the appropriate channel icon(s).

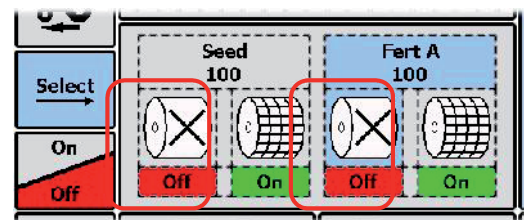

## 3.5 Work Status

Sensor(s) detect when the drill is raised out of work or lowered into work, and the work status is displayed at the top of the screen.

Drill is out of work / Metering is stopped / Area totals accumulation is stopped.



Drill is in work / Normal metering is in progress (unless being manually overridden – ref. section 3.4) / Area totals are accumulating.



As above and also indicating a tramlining bout (ref. section 3.8).



# 'Renovator AS5300' Read Before Operation

## 3.6 Setting the Application Rate

### 3.6.1 Seed and fertiliser

The drilling rate is metric units only i.e. kgs/ha.

To set the Target rate for a selected channel:

First select the channel that you want to set the rate for.

Press **Set**, enter the required rate then touch "OK".

The maximum speed to maintain the application is calculated and displayed. Press "OK" to return to the main screen.

The system will then automatically maintain this rate irrespective of forward speed (within limits).

#### To manually override the Rate for a selected channel:



For the selected channel, at any time you can adjust the rate up or down in 5% increments to suit field conditions, up to a maximum  $\pm 50\%$  from the target rate.

Press  to return to the target rate.

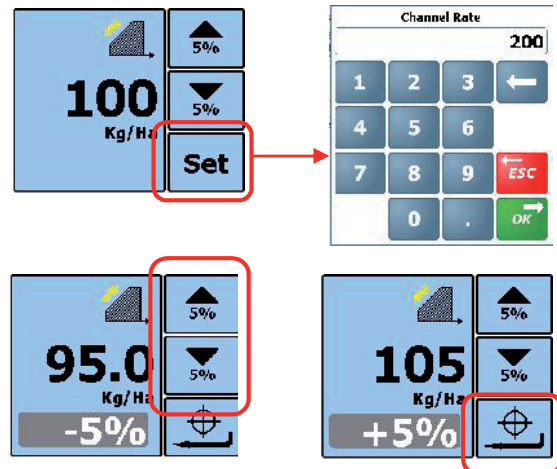
**NOTE:** The main screen page will not display or otherwise remind you of an off-target rate set for a channel, unless that channel remains selected.



### 3.6.2 Pellet/ Small seed Applicator

Where fitted, a pellet / small seed applicator will be factory-configured for either of two modes of operation – 'Fan' or 'Spinner'. The mode is indicated by the  or  icon in the rate window.

When the Applicator channel on the main operating screen is selected, due to its different mode of operation, the rate window appears slightly differently to that for normal seed / fertiliser channels.

#### Applicator in Fan configuration

Set / manually override the target rate as for other seed / fertiliser channels (3.6.1)

Touch the rate window to toggle to the fan On/Off control. The fan is normally left on but should you need to, press  to switch it off as required.

**NOTE:** The fan on/off control operates independently of the metering motor on/off control.

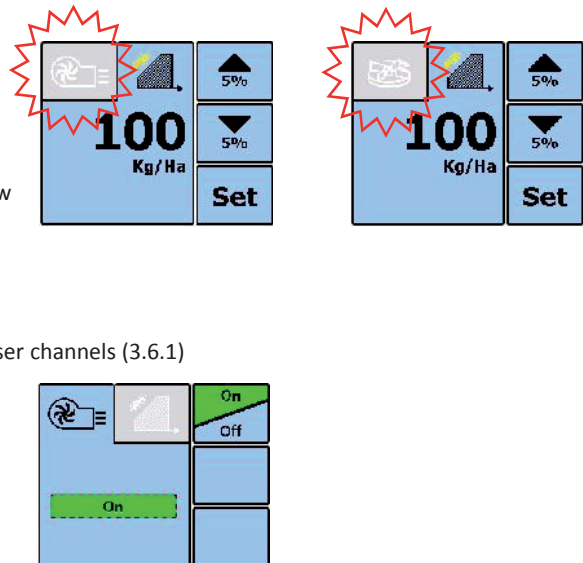

#### Applicator in Spinner configuration

Set / manually override the target rate as for other seed / fertiliser channels (3.6.1)

Touch the rate window to toggle to the spinner speed control and on/off control.

The spinner speed may be set between 0 -100% (PWM). It is a matter of trial and error to establish the % setting to achieve the desired spread width.

Press **Set**, enter the required % speed then touch "OK".

The spinner(s) are normally left on but should you need to, press  to switch them off as required.

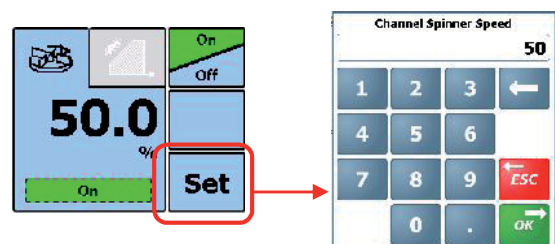

# 'Renovator AS5300' Read Before Operation

## 3.7 Pre-start Sequence

Particularly useful in the case of a front-mounted hopper, the pre-start function helps to avoid an un-seeded area on entering work. It starts the metering unit at the calibration speed while the drill is still stationary, and 'primes' the drill so that the seed reaches the coulters just as the drill enters work.

User Settings:



Cycle to the 'Drill Setup' screen and touch the  tab to view the 'Pre-start Duration' and 'Pre-start Mode'.

### Pre-start Duration:

The pre-start duration is established by trial and error tests when the system is first set up. The duration can be set from zero to 9.9 seconds.

Pre-start Mode:

'**AUTO**' mode – the Pre-start function is automatically triggered when the drill is switched into work.

'**Man**' mode - the pre-start sequence is optional.

As required, simply press the  key before moving off.

The metering motor will run at the calibration speed for the set duration, or until the forward speed exceeds the simulation speed, when full proportional control then takes over.

While the pre-start duration is active and the forward speed remains below the simulation speed, the duration counts down and the Forward Speed display is highlighted yellow.

Once the simulation speed is reached, pre-start is cancelled and the screen returns to the normal forward speed display.

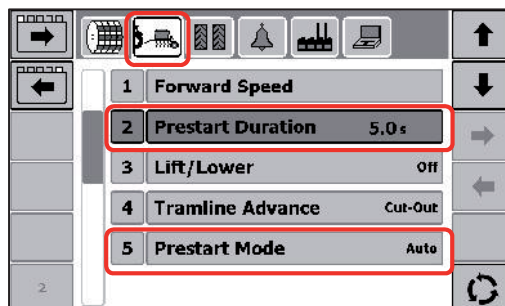

UK805-040.PNG

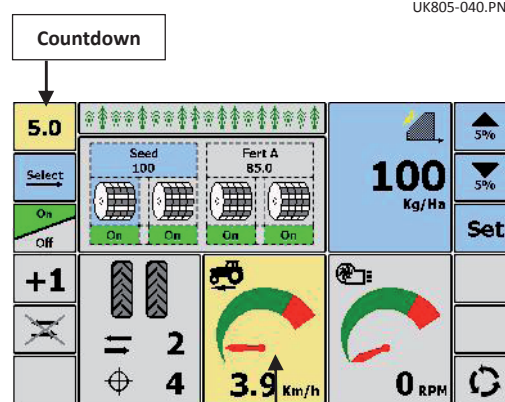

UK805-050.PNG

# 'Renovator AS5300' Pre-Calibration Setup

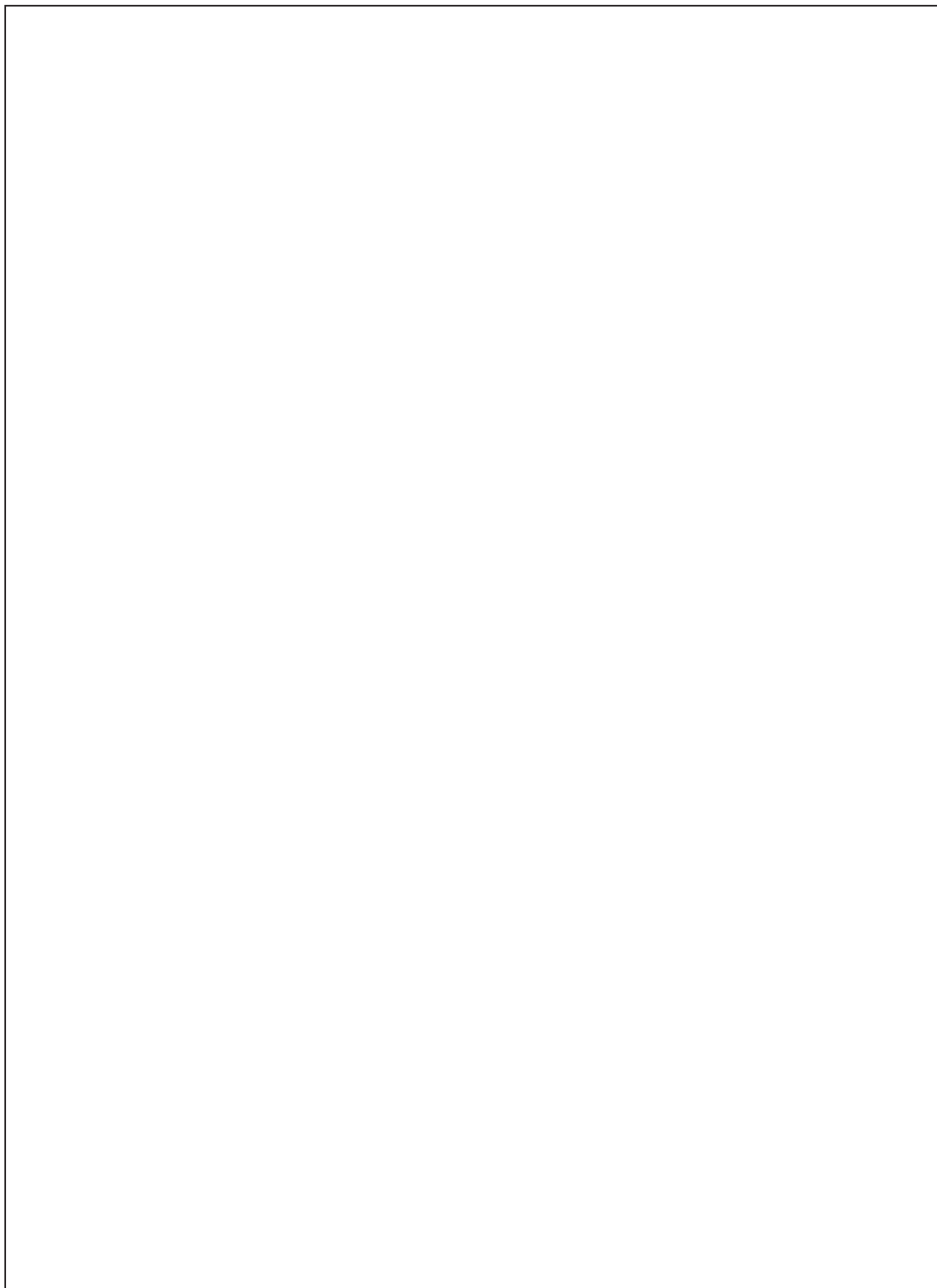

# 'Renovator AS5300' Pre-Calibration Setup

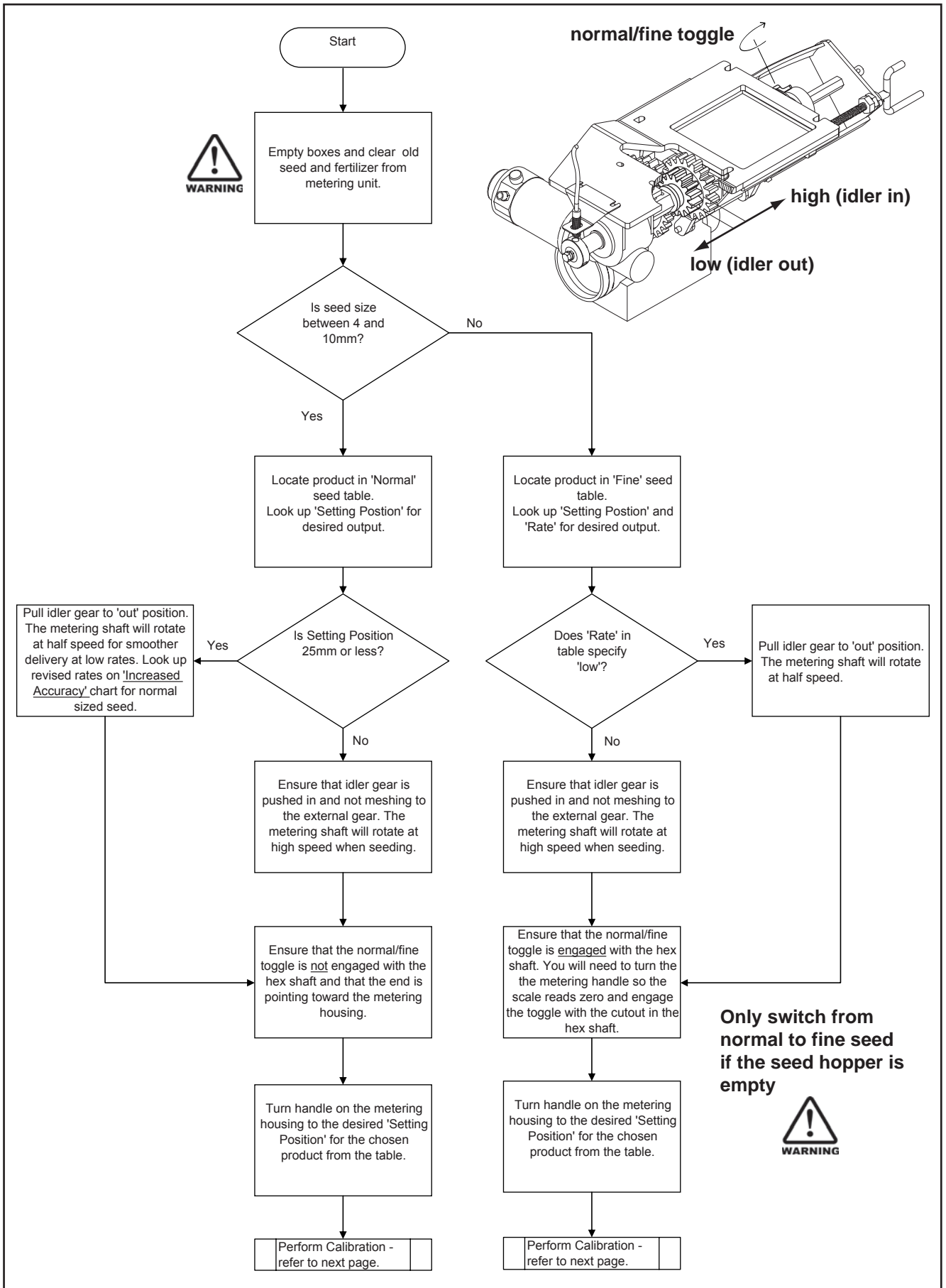

# 'Renovator AS5300' Calibration

## 5. Product Calibration

There are two ways of running the calibration test,

- from the head unit.
- via the relevant priming switch on on the drill.

**Note:** It is recommended that the drill be calibrated using the Priming Switch Method

### 5.1 Running the test from the Cab



1. From the main drilling screen, set the target rate for the channel(s) to be calibrated.
2. Setup the drill in the usual way for a bucket test on the appropriate metering unit.
3. Cycle to the 'Drill Setup' screen.

The screen displays the channel configuration as shown on the main operating screen. If multiple channels are configured, the calibration routine must be repeated for each channel including linked channels (  ).

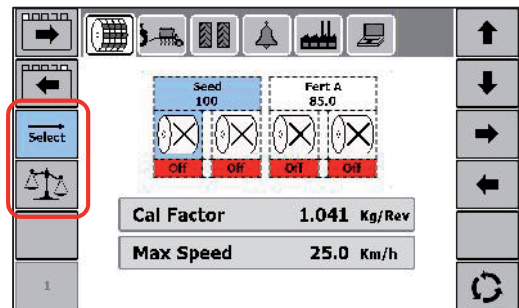
4. Press  to select the channel to calibrate, then press  .



UK805-160.PNG

5. Press  or  , (your preference) and enter the weight that you wish to meter out for the bucket test.



6. Press  .



UK805-175.PNG

The metering unit will then operate (based on the simulation speed) to dispense the programmed amount of product, then stops.

**NOTE:** At any time you can touch  to curtail the test.



UK805-180.PNG

The instrument then displays a weight figure based on the existing, programmed product calibration factor.

**NOTE:** In the case of a single motor / dual metering configuration (  ) the product collected, weighed and programmed is that from BOTH metering units.

So in this case, before going to step 7, press  and repeat steps 5 and 6 for the second metering unit, then total both weights.



# 'Renovator AS5300' Calibration

7. Weigh the contents of the container. Press **Gram** or **Kg**, (your preference) and enter the weight THAT WAS DISPENSED.

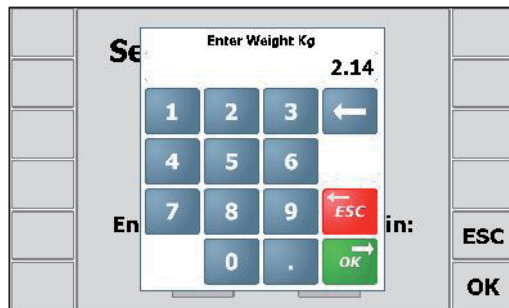

UK805-210.PNG

8. Press **OK**.

The new calibration factor (kg/rev), % error and the maximum forward speed that is permissible based on the application rate set for the channel.

9. Press **OK** to return to the "Drill Setup" screen.



UK805-200.PNG

## 5.2 Running the test using the Priming Switch

1. From the main drilling screen, first set the target rate for the channel(s) to be calibrated.
2. Setup the drill in the usual way for a bucket test on the appropriate metering unit.
3. Press the priming switch to meter out the desired amount of product.

**NOTE:** Depending on your particular drill configuration, the priming switch(es) will be setup for either momentary or latching operation.

*If set to latching, then press and release the switch to start metering, then press and release again to stop.*

*If set to momentary, then press and hold the switch to start metering, and release to stop.*

The displays switches automatically to the calibration screen once the priming switch is pressed.

When the metering unit is stopped, the instrument then displays a weight figure based on the existing programmed product calibration factor.

**NOTE:** In the case of a single motor / dual metering configuration (  ) the product collected, weighed and programmed is that from BOTH metering units.

So at this point, press **ESC** and repeat steps 2 and 3 for the second metering unit, and total the dispensed weights.



UK805-180.PNG



UK805-190.PNG

4. Weigh the contents of the container. Press **Gram** or **Kg**, (your preference) and enter the weight THAT WAS DISPENSED.



# 'Renovator AS5300' Calibration

5. Press **OK** .

The new calibration factor (kg/rev), % error and the maximum forward speed that is permissible based on the application rate set for the channel.

6. Press **OK** to return to the main operating screen.

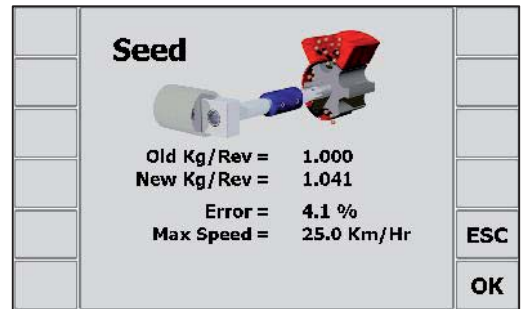

UK805-200.PNG

## 5.3 Calibrating systems with 'Accord' type metering mechanisms.

When changing from a low rate to a high rate i.e. 3kg/ha to 100kg/ha

For each channel,

1. Move the metering slide to a position for the higher rate.
2. Perform the calibration test and enter the weight dispensed (as in 5.1 / 5.2).
3. The error will be considerable, but press **OK** to accept the error and continue.
4. From the main drilling screen, set the required target rate for the channel.
5. Perform the product calibration routine again.
6. The error this time will be marginal.
7. Press **OK** to accept the error, and begin drilling.

When changing from a high rate to a low rate i.e. 100kg/ha to 3kg/ha :

For each channel,

1. Move the metering slide to a position for the lower rate.
2. Perform the calibration test and enter the weight dispensed (as in 5.1 / 5.2).

*NOTE: If using the priming switch simply dispense a small amount of product and enter the weight.*

3. The error will be considerable, but press **OK** to accept the error and continue.
4. From the main drilling screen, set the required target rate for the channel.
5. Perform the product calibration routine again, this time dispensing a suitable amount of product.
6. The error this time will be marginal.
7. Press **OK** to accept the error, and begin drilling.



# 'Renovator AS5300' Calibration Notes

Blank lined area for notes.

# 'Renovator AS5300' Seed Drill Sowing Chart

**NORMAL SEED (toggle NORMAL, Butterfly Valve Settings shown below and on page 30)**

AS5300 5,6,7

PRODUCT	SPECIFIC GRAVITY (kg/l)	Setting Position> RATE*	*10*	*15*	*20*	*25*	30	35	40	45	50	55	60	65	70	75	80	85	90	95	100	105	110
Wheat	0.77	high	18	27	37	46	56	66	75	85	94	104	113	123	133	142	151	161	170	181	190	199	209
Oats	0.5	high	13	19	25	32	38	44	51	57	64	70	76	82	89	95	102	108	114	121	127	134	140
Barley	0.68	high	17	26	35	43	51	60	68	77	86	94	102	111	120	128	136	144	153	162	170	179	188
Ryecom	0.74	high	18	26	36	45	54	63	72	81	91	99	108	117	127	136	145	154	163	172	182	191	200
Peas	0.81	high	11	22	32	42	52	63	73	84	94	105	115	125	135	146	156	167	177	187	197	208	218
Grass	0.36	high		10	14	18	23	27	32	37	42												
Pasture Mix	-	high		10	14	18	23	27	32	37	42												
DAP	1.03	high	21	31	42	52	63	73	84	94	104	115	125	135	146	156	167	177	188	198	208	219	229
Superphosphate	1.26	high	18	38	59	74	92	110	127	143	163	181	197	210	227	243	264	282	301	316	335	356	

**INCREASED ACCURACY FOR SETTING POSITION<25mm (toggle NORMAL, Butterfly Valve Settings shown below and on page 30)**

PRODUCT	SPECIFIC GRAVITY (kg/l)	Setting Position> RATE*	*10*	*15*	*20*	*25*	30
Wheat	0.77	low	9.2	13.7	18.6	23.2	28.0
Oats	0.5	low	6.5	9.4	12.7	15.9	19.1
Barley	0.68	low	8.6	12.9	17.3	21.3	25.6
Ryecom	0.74	low	8.9	13.2	17.8	22.4	27.0
Peas	0.81	low	5.7	10.8	15.9	21.0	26.1
Grass	0.36	low	-	4.9	7.0	9.2	11.3
Pasture Mix	-	low	-	4.9	7.0	9.2	11.3

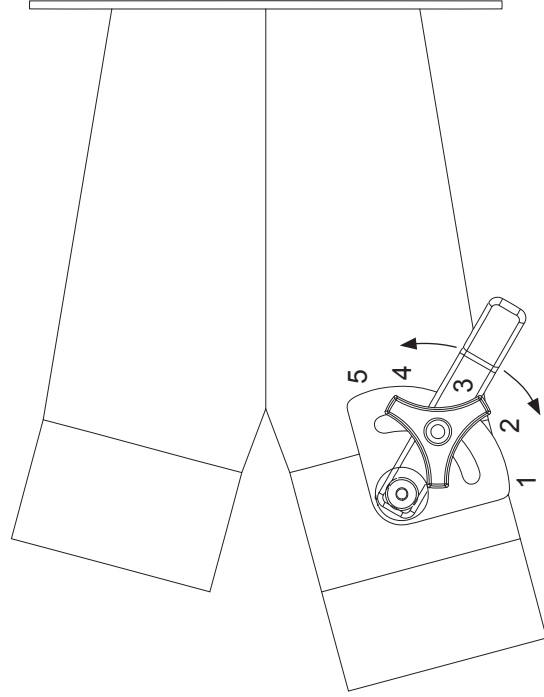

Box contents		Butterfly Position (affects rear box)		Fan Speed/rpm*
FRONT	REAR			
seed (Normal)	seed (Normal)	open	- 5	3000
seed (Normal)	seed (Fine)	closed	- 1	3000
Fertilizer	seed (Normal)	closed	- 2	3000 to 3500
Fertilizer	seed (Fine)	closed	- 1	3000 to 3500

\*MAXIMUM PERMISSABLE SPEED 4000 RPM

# 'Renovator AS5300' Seed Drill Sowing Chart

FINE SEED (toggle 'FINE', Butterfly Valve Settings shown below and on page 30)

AS5300 5,6 7"

PRODUCT	SPECIFIC GRAVITY (kg/l)	Setting Position>	2.5	5	7.5	10	12.5	15	17.5	20	22.5	25
			RATE ONCE SET DO NOT REDUCE/CLOSE WITH SEED IN BIN**									
Lucerne (Alfalfa)	0.77	low	0.59	1.65	2.48	3.50	4.27	5.03	6.08	6.98	7.76	8.36
Turnip	0.65	low	0.59	1.24	1.83	2.45	3.07	3.69	4.29	4.91	5.53	6.15
Kale	0.65	low	0.59	1.24	1.83	2.45	3.07	3.69	4.29	4.91	5.53	6.15
Swedes	0.65	low	0.59	1.24	1.83	2.45	3.07	3.69	4.29	4.91	5.53	6.15
Canola/Rape	0.65	low	0.59	1.24	1.83	2.45	3.07	3.69	4.29	4.91	5.53	6.15
White Clover	0.77	low	0.62	1.43	2.32	3.23	4.12	4.85	5.74	6.47	7.17	7.41
Red Clover	0.77	low	0.62	1.43	2.32	3.23	4.12	4.85	5.74	6.47	7.17	7.41
Grass	0.36	low			0.75	1.40	1.94	2.48	3.02	3.56	4.04	4.37
Millet	0.64	low		0.60	1.24	1.96	2.59	3.13	3.67	4.42	4.96	5.55
Grain Sorghum	0.56	low		0.17	1.51	3.23	4.04	4.58	5.66	6.58	7.39	8.46
Forage Sorghum	0.56	low		0.17	1.51	3.23	4.04	4.58	5.66	6.58	7.39	8.46
Chicory	0.54	low	0.31	0.99	1.56	2.20	2.73	3.36	4.06	4.64	5.14	5.60
Lucerne (Alfalfa)	0.77	high	1.19	3.30	4.96	7.00	8.55	10.07	12.16	13.96	15.51	16.71
Turnip	0.65	high	1.19	2.48	3.67	4.91	6.15	7.39	8.57	9.81	11.05	12.29
Kale	0.65	high	1.19	2.48	3.67	4.91	6.15	7.39	8.57	9.81	11.05	12.29
Swedes	0.65	high	1.19	2.48	3.67	4.91	6.15	7.39	8.57	9.81	11.05	12.29
Canola/Rape	0.65	high	1.19	2.48	3.67	4.91	6.15	7.39	8.57	9.81	11.05	12.29
White Clover	0.77	high	1.24	2.86	4.64	6.47	8.25	9.70	11.48	12.94	14.34	14.82
Red Clover	0.77	high	1.24	2.86	4.64	6.47	8.25	9.70	11.48	12.94	14.34	14.82
Grass	0.36	high			1.51	2.80	3.88	4.96	6.04	7.12	8.09	8.73
Millet	0.64	high		1.21	2.48	3.92	5.18	6.25	7.33	8.84	9.92	11.10
Grain Sorghum	0.56	high		0.35	3.02	6.47	8.09	9.16	11.32	13.15	14.77	16.93
Forage Sorghum	0.56	high		0.35	3.02	6.47	8.09	9.16	11.32	13.15	14.77	16.93
Chicory	0.54	high	0.63	1.98	3.13	4.40	5.46	6.73	8.12	9.28	10.29	11.20

\*\*Setting may only be reduced by a large amount if unit is turning or bin and metering device clear of product else damage will occur. Do not open the setting above '25' with the toggle set to 'fine' as the adjuster will break.

Box contents		Butterfly Position (affects rear box)	Fan Speed/rpm*
FRONT	REAR		
seed (Normal)	seed (Normal)	open - 5	3000
seed (Normal)	seed (Fine)	closed - 1	3000
Fertilizer	seed (Normal)	closed -2	3000 to 3500
Fertilizer	seed (Fine)	closed - 1	3000 to 3500

\* MAXIMUM PERMISSABLE FAN SPEED 4000 RPM

# 'Renovator AS5300' Airflow & Fan Speed

## Airflow and Fan Settings

### 1. Hydraulic Fan -connect the hoses in the following order:

First - connect Zero pressure Case Drain 3/8" hose (1/2" BSP Female QR) to hydraulic reservoir \*



Second -connect Motor Return 3/4" hose (3/4" BSP Female QR) to tractor high flow low pressure return port.

Finally - connect High Pressure Motor Feed 1/2" hose (1/2" BSP Male QR) to tractor remote.

Disconnect in the reverse order to prevent motor seal damage.

\*The tractor hydraulic reservoir or free drain connection must have zero backpressure.



2. A higher fan speed is usually required to correctly deliver high rate or heavier product such as fertilizer from the front box. The airflow to the rear box is reduced by setting the butterfly valve to the appropriate position as shown in the table. If this is not done the seed delivered to the disc units from the rear box may well bounce out of the seed slot.

The following table shows box fill combinations, butterfly position and recommended fan speeds for normal/fine seeds and fertilizer:-

Box contents		Butterfly Position (affects rear box)	Fan Speed/rpm*
FRONT	REAR		
seed (Normal)	seed (Normal)	open - 5	3000
seed (Normal)	seed (Fine)	closed - 1	3000
Fertilizer	seed (Normal)	closed -2	3000 to 3500
Fertilizer	seed (Fine)	closed - 1	3000 to 3500

\* MAXIMUM  
PERMISSABLE  
FAN SPEED  
4000 RPM

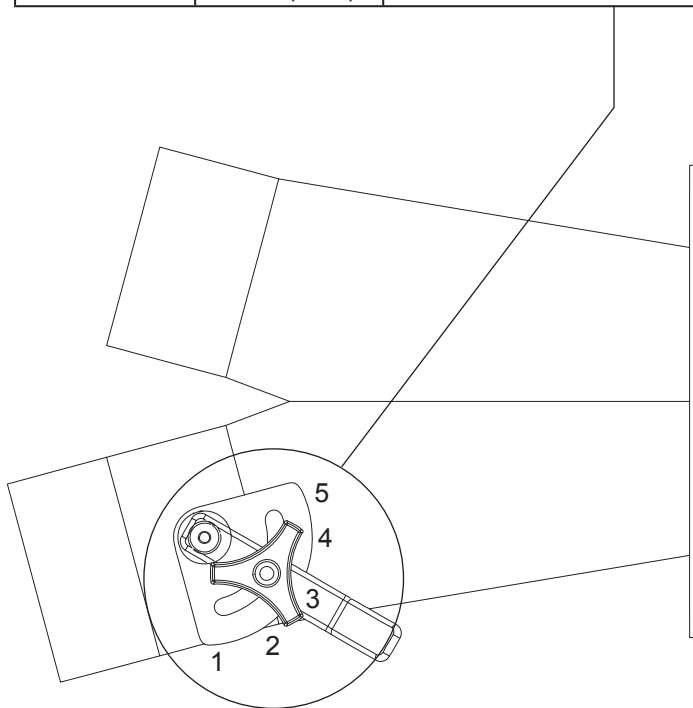

# Renovator AS5300 Calibration Notes

Lined area for calibration notes.

# 'Renovator AS5300' Maintenance & Care

## Maintenance & Care

### General Safety and Accident Prevention Advice



- 1 Make sure that if the tractor remains attached to the drill that the ignition key is removed.
- 2 During maintenance the drill should be supported in such a manner that if hydraulic failure was to occur the machine would still be adequately supported.
- 3 Wear gloves when handling components with cutting edges such as worn discs etc...
- 4 Disconnect the electrical supply from the tractor before doing any electrical maintenance.
- 5 Refer to safety sections for more safety information.

### General Cautionary Maintenance Advice



- 1 **Electric Welding** - With the electronic equipment in modern tractors it is advisable to completely disconnect the implement from the tractor, or at the very least disconnect the alternator before attempting any welding.
- 2 **Hydraulics** - Ensure hydraulic couplings (male & female) are clean before connecting. Dirty couplings will result in hydraulic oil contamination and hydraulic cylinder seal and valve damage. This in turn will result in oil leakage.  
  
No filter is fitted to the hydraulic system. If hydraulic fittings and oil supply are not going to be kept clean it is recommended that a filter be fitted to prevent hydraulic cylinder damage.
- 3 **Water Blasting** - Water blasting, steam cleaning or other pressurised cleaning processes can force dirt etc. into undesirable places that may cause damage or rapid part wear to items such as bearings, seals, chains, bushes and electrical items etc.  
Caution must be exercised.

# 'Renovator AS5300' Maintenance & Care

## Maintenance & Care - Lubrication Instructions

### Precautions with Grease

Greases should not be mixed as the structure may be weakened by the mixes of different types of thickener, which may cause softening and loss of grease from the bearings by running out.



Your new Duncan Renovator AS5300 Seed Drill will give long and efficient service if given normal care and maintained properly.

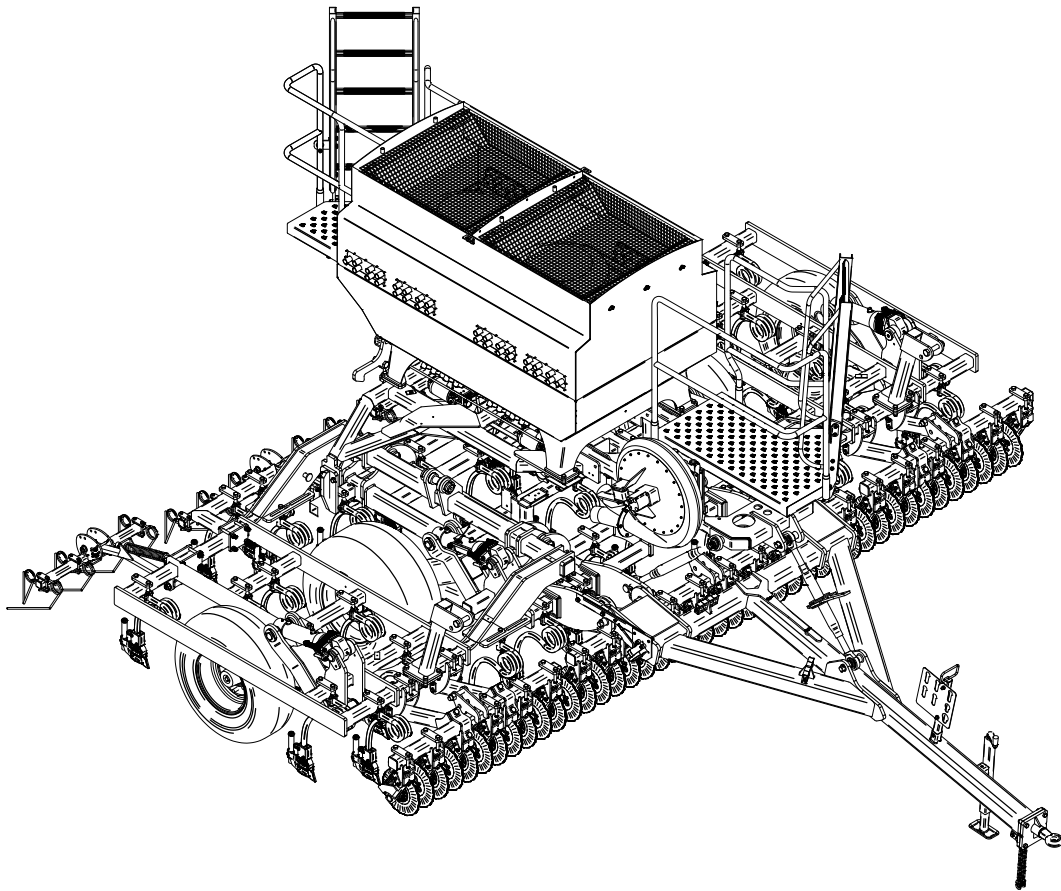

### Lubrication Chart

Item	Components	Lubricant	Frequency
1	All Wheel Bearings	Castrol LMX Grease	Annually
2	All Pivot Points, Clevises	Castrol LMX Grease	Weekly
3	Bearing Housings (roller)	Castrol LMX Grease	Weekly
4	Turnbuckle	Castrol LMX Grease	Monthly
5	Coupling	Castrol LMX Grease	Weekly

\* The lubrication frequencies are only a guide. Actual frequency will be dependent on extent of use and ground conditions.

# 'Renovator AS5300' Maintenance & Care

## Maintenance & Care - Schedule

Components	Daily	Weekly	Pre Season
	(or after 20Ha)	(or after 75Ha)	(or 500 Ha)
Swivel Hitch Coupling	•	•	•
Disc Openers	•	•	•
Metering Units	•	•	•
Box Cover	•	•	•
Pivot Pins incl Ram Clevis		•	•
Pivot Pin Fasteners		•	•
Hydraulics (Oil Leaks)		•	•
Electrics		•	•
Seed Hoses		•	•
Tines & T Boots		•	•
Tyres & Tyre Pressures		•	•
Bolted Connections			•

### Maintenance Schedule

(Refer also to Summary Chart, above)

#### 1 Bolted Connections

All bolted connections of the machine should be checked after the first 3 to 5 hours of operation and retightened if necessary and thereafter at regular intervals. It is suggested that this is done every 500 hectares or annually, whichever occurs first.

#### 2 Pivot Pins & Ram Clevis

Pivots must be greased regularly (weekly or after every 75Ha) to provide lubrication and flush out any dirt.

#### 3 Framework

The framework structure should be inspected annually for defects, i.e., cracks in members or welded connections. The framework should be cleaned prior to the inspection.

#### 4 Metering Units

Ensure that the metering units are clean and that the rubber sealing lip is not damaged. The sealing lip is located along the base of the trap door hinge. A damaged sealing lip can cause seed delivery problems.



# 'Renovator AS5300' Maintenance & Care

## Maintenance Schedule (continued)

### 5 Fan Hydraulic Motor

Hydraulic Fan -connect the hoses in the following order:

First - connect Zero pressure Case Drain 3/8" hose (1/2" BSP Female QR) to hydraulic reservoir \*

Second -connect Motor Return 3/4" hose (3/4" BSP Female QR) to tractor high flow low pressure return port.

Finally - connect High Pressure Motor feed 1/2" hose (1/2" BSP Male QR) to tractor remote.

Disconnect in the reverse order to prevent motor seal damage.



**\*The tractor hydraulic reservoir or free drain connection must have zero backpressure.**

### 6 Preparing the Machine for Storage.

Locate on a dry level surface. The machine should be stored wherever possible so the rams are not supporting any weight. The drive chains should be lubricated with suitable roller chain lubricant before prolonged periods of storage.

It is recommended that maintenance be carried out at the end of the season, giving sufficient time to obtain spare parts and/or carry out repairs if required. The seed and fertilizer bins must be completely emptied and cleaned.

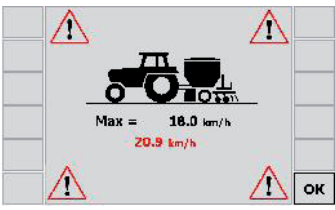
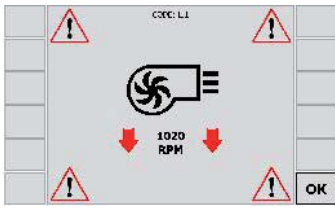

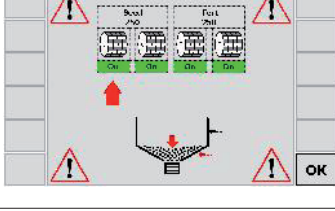
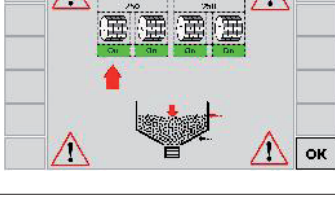
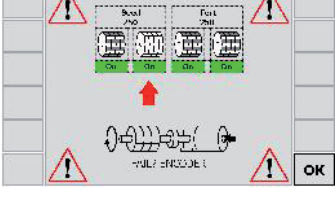
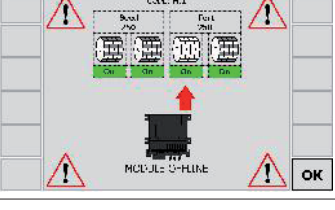
# 'Renovator AS5300' Alarm Codes

No.	Code	Screen	Reason	Check?
1	N/A		<p><b>High forward speed</b></p> <ul style="list-style-type: none"> <li>Forward speed exceeds the maximum calculated and displayed on the RATE screen</li> </ul>	<ul style="list-style-type: none"> <li>Target application rate is as required</li> <li>Calibration factor is realistic</li> <li>Adjust metering unit and recalibrate which will increase kg/rev factor and therefore increase maximum achievable forward speed</li> </ul>
2	L.1		<p><b>Low fan speed</b></p> <ul style="list-style-type: none"> <li>Fan speed below the low alarm value programmed</li> </ul>	<ul style="list-style-type: none"> <li>Fan is actually operating</li> <li>Sensor &amp; target functioning and correct</li> <li>PPR value programmed correctly</li> </ul>
3	L.2		<p><b>High fan speed</b></p> <ul style="list-style-type: none"> <li>Fan speed is above the high alarm value programmed</li> </ul>	<ul style="list-style-type: none"> <li>Sensor &amp; target functioning and correct</li> <li>PPR value programmed correctly</li> </ul>
4	L.3.1		<p><b>Low hopper level alarm</b></p> <ul style="list-style-type: none"> <li>Channel with low level highlighted</li> </ul>	<ul style="list-style-type: none"> <li>Level is actually low</li> <li>Sensor is functioning correctly</li> <li>Wiring between sensor and connection box is correct</li> <li>Wiring between connection box and CAN module is correct</li> </ul>
5	L.3.2		<p><b>Pre-Level hopper alarm</b></p> <ul style="list-style-type: none"> <li>Channel with low pre level highlighted</li> </ul>	<ul style="list-style-type: none"> <li>Level is actually low</li> <li>Sensor is functioning correctly</li> <li>Wiring between sensor and connection box is correct</li> <li>Wiring between connection box and CAN module is correct</li> </ul>
11	M.3.1		<p><b>Motor speed signal from motor not being received</b></p> <ul style="list-style-type: none"> <li>Motor being operated and pulses received from shaft confirmation sensors but no motor speed signal</li> </ul>	<ul style="list-style-type: none"> <li>Signs of mechanical damage to encoder or cabling on motor</li> <li>3way connector between motor and harness is correct</li> <li>Wiring between 3way connector and module connector is correct</li> </ul>
12	M.1		<p><b>MCM or APM is offline'</b></p>	<ul style="list-style-type: none"> <li>Check wiring between 6way connector and module connector on MCM harness</li> </ul>

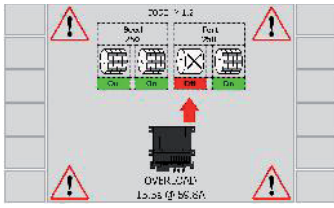
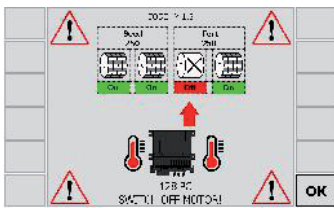
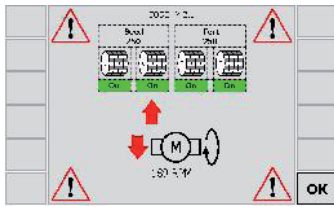
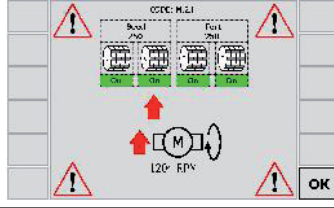
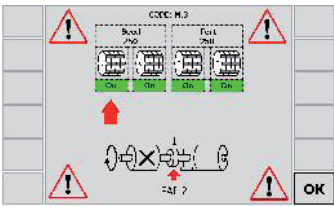
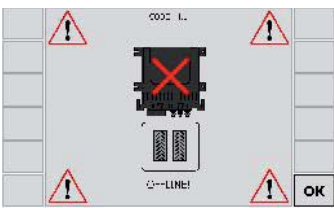
# 'Renovator AS5300' Alarm Codes

No.	Code	Screen	Reason	Check?
13	M.1.2		<b>Module overload shutdown</b> <ul style="list-style-type: none"> <li>Motor current requirement exceeded, so the module is shutdown and motor operation is inhibited</li> </ul>	The Motor is stalled. <ul style="list-style-type: none"> <li>Excessive drag on the metering unit, requiring motor high current.</li> </ul>
14	M.1.3		<b>Motor module temperature shutdown</b> <ul style="list-style-type: none"> <li>Module temperature has exceeded the value programmed</li> </ul>	The Motor speed is very low. Excessive load applied to motor which for a prolonged time, causing the module high temperature and shutdown. Check metering unit for damage / obstruction. <ul style="list-style-type: none"> <li>Re-calibrate to get motor turning faster.</li> </ul>
15	M.2.L		<b>Motor speed low</b> <ul style="list-style-type: none"> <li>Error between actual motor speed and target motor speed is greater than 10%</li> </ul>	<ul style="list-style-type: none"> <li>Target motor speed to high</li> <li>Erratic forward speed signal</li> <li>Erratic loading on motor via metering unit</li> </ul>
16	M.2.H		<b>Motor speed high</b> <ul style="list-style-type: none"> <li>Error between actual motor speed and target motor speed is greater than 10%</li> </ul>	<ul style="list-style-type: none"> <li>Target motor speed to high</li> <li>Erratic forward speed signal</li> <li>Erratic loading on motor via metering unit</li> </ul>
17	M.3		<b>Metering unit is not going around</b>	<ul style="list-style-type: none"> <li>Is metering unit rotating when motor rotates</li> <li>Sensor &amp; target functioning and correct</li> <li>PPR value programmed correctly Wiring between sensor and connection box is correct</li> <li>Wiring between connection box and CAN module is correct</li> </ul>
18	-		-	-
19	H.1		<b>Tramline module is 'offline'</b>	<ul style="list-style-type: none"> <li>Check module has got power from main battery power cable</li> <li>Check wiring between 4way connector and module connector on HBM harness</li> </ul>

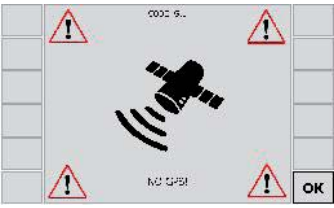
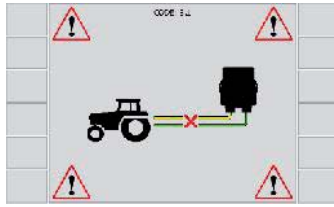
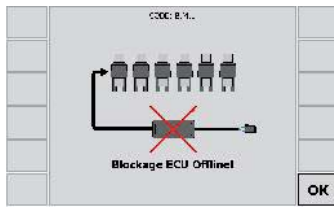
# 'Renovator AS5300' Alarm Codes

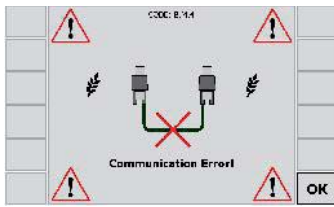
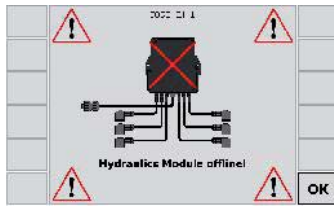
No.	Code	Screen	Reason	Check?
20	G.1		GPS signal lost.	<ul style="list-style-type: none"> <li>Check connections to GPS antenna.</li> <li>Check GPS coverage for Area</li> </ul>
21	B.1		Bridge Module is 'offline'	
22	B.M.1		Blockage monitoring ECU is 'offline'	<ul style="list-style-type: none"> <li>Check power supply to blockage ECU</li> <li>Check wiring between power harness and blockage ECU</li> <li>Check LEDs are lit and flashing on blockage ECU</li> </ul>
23	B.M.2		Wrong number of blockage sensors is detected	<ul style="list-style-type: none"> <li>The correct number of sensors is programmed in blockage ECU setup</li> <li>All sensors are wired correctly and connected</li> </ul>
24	B.M.3		Blocked sensor/row	<ul style="list-style-type: none"> <li>Row or pipe is actually blocked</li> </ul>
25	B.M.4		Communication break between blockage sensors	<ul style="list-style-type: none"> <li>Wiring between blockage sensors</li> <li>The correct number of sensors is programmed</li> </ul>
26	E.H.1		Electro hydraulic module offline	<ul style="list-style-type: none"> <li>Check wiring between 4way superseal and connection to the main loom.</li> </ul>

# 'Renovator AS5300' Diagnostics

## 10. Diagnostics

Press  to cycle to the Settings screen.

"1. Instrument" simply indicates the supply voltage.

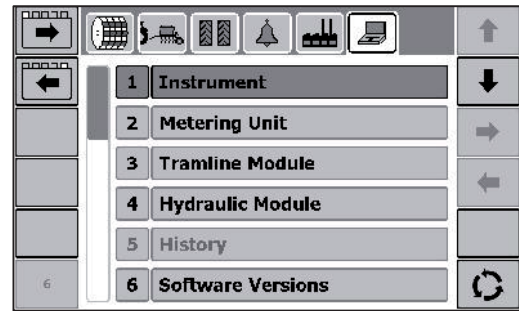

UK805-270.PNG

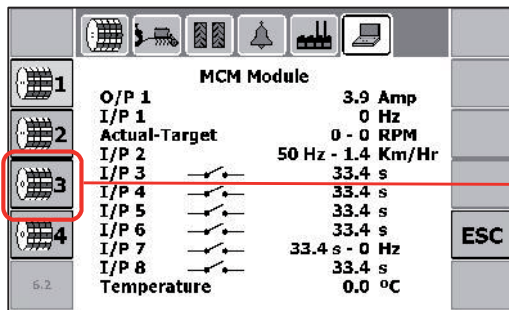

"2. Metering Unit" indicates the status of each Motor Control Module (MCM) and if applicable, the Applicator Control Module (APM). MCM I/O functions are not defined as they can vary depending on the drill, but are typically as follows, I/P 1=Encoder, I/P 2=Forward speed, I/P 3 and 4= Metering confirmation shaft(s), I/P 5=Priming switch, I/P 6=Cutout status, I/P 7 and 8=Hopper Level (sometimes these may be Cutout status).

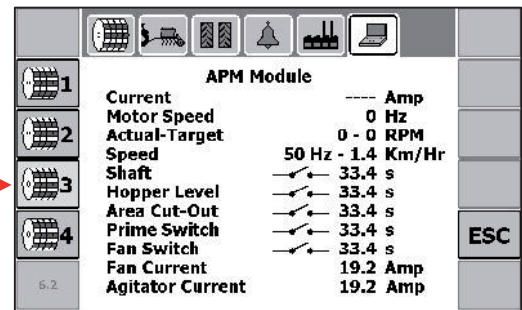

UK805-280.PNG



UK805-310.PNG

"3. Tramline Module" indicates the status of the H-bridge Module (HBM). Press  or  to test the tramline mechanisms "TL Left" and "TL Right". If operational, a current draw is indicated.

"4. Hydraulic Module". Output functions 1 to 8 are not defined as they are dependent on the make and model of drill. Please refer to the drill manufacturer for further information on hydraulic functionality.

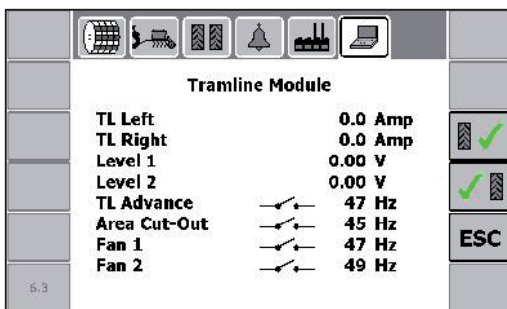

UK805-290.PNG

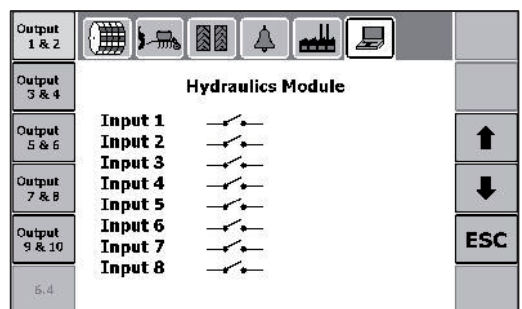

UK805-300.PNG

"6. Software versions".

NOTE: Software versions can also be viewed via the "Dashboard" (  "Global Settings" > "About System").



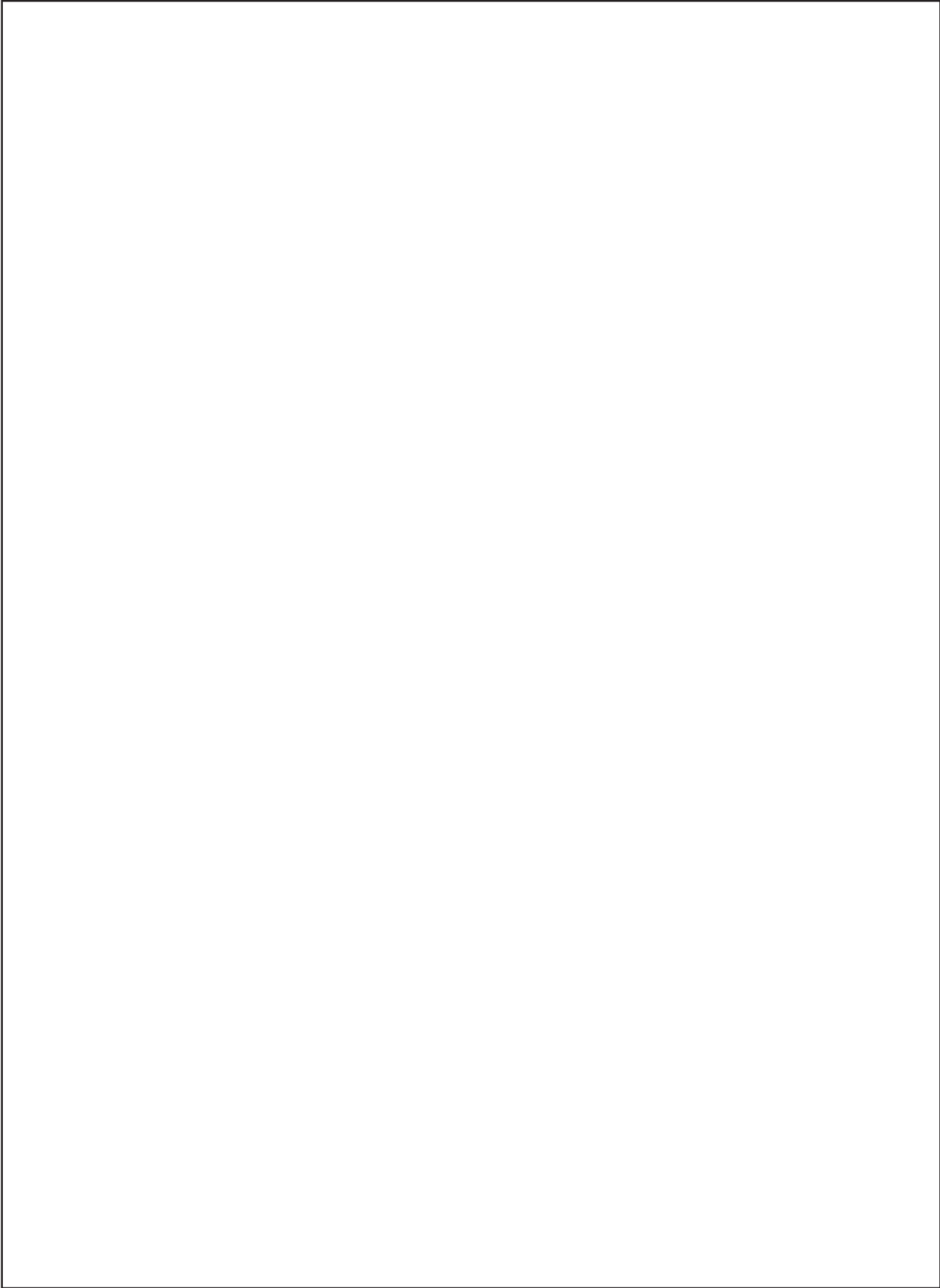

# Parts List



## Renovator AS5300

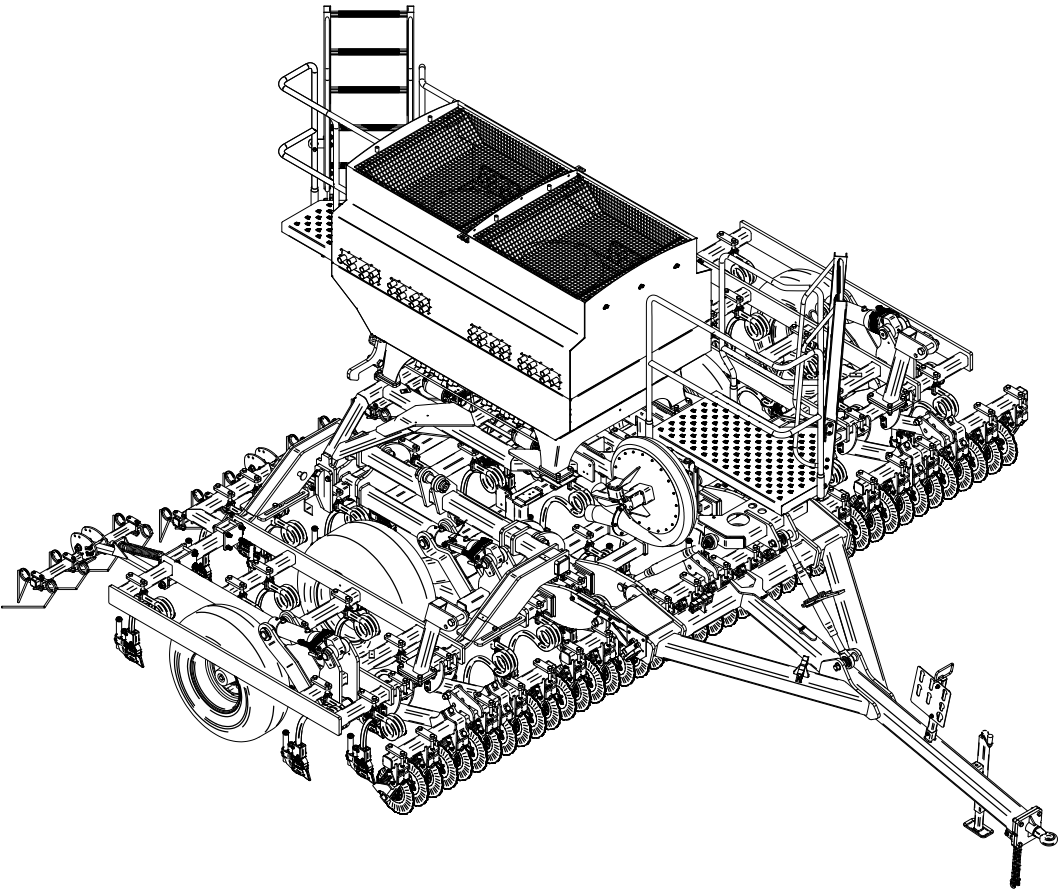

*Built to work.*

# 'Renovator AS5300' Disc Opener Parts

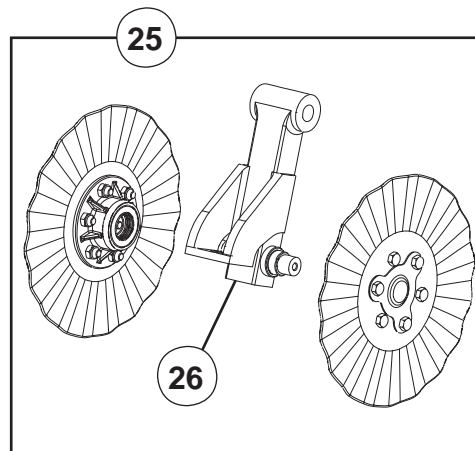
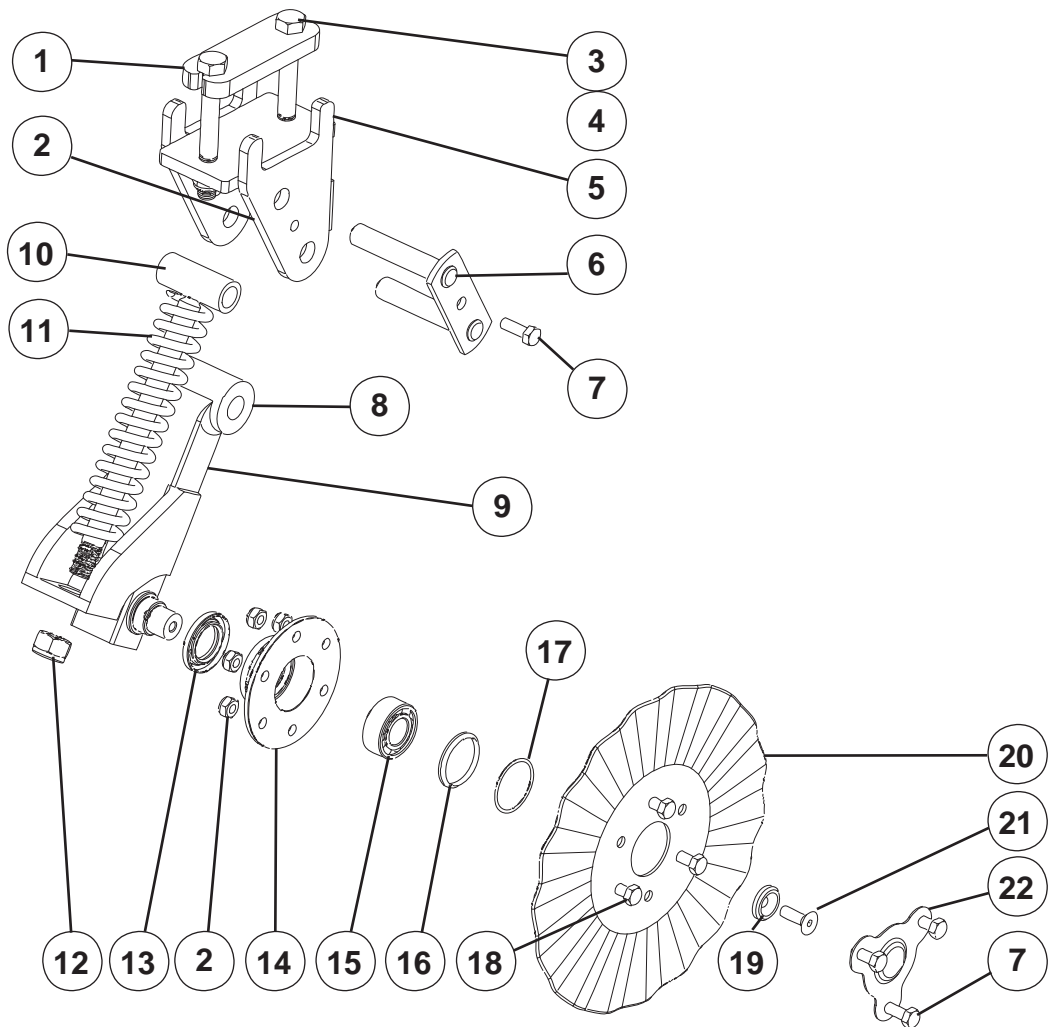



# ‘Renovator AS5300’ Disc Opener Parts

ITEM	PART No.	DESCRIPTION	QTY
1	21690	Clamp Plate	-
2	45138	M10 Nyloc Nut	-
3	45051	M16 X 130 Class 8.8 Bolt	-
4	45140	M16 Nyloc Nut	-
5	60460	Mounting Bracket	-
6	60450	Double Pivot Pin Assembly	-
7	45004	M10 x 35 Class 8.8 Bolt	-
8	43118	Grease Nipple Straight	-
9	LH=60455 RH=60457	Axle Arm (RH Shown in exploded view)	-
10	26310	T Bolt Spring Rod	-
11	60294	Disc Opener Spring	-
12	45141	M20 Nyloc Nut	-
13	45650	Seal	-
14	60466	Housing	-
15	45652	Bearing	-
16	60469	Bearing Retainer	-
17	45653	O Ring Seal	-
18	45002s	M10 x 25 Class 8.8 Set Screw	-
19	60444	Bearing Retainer	-
20	22035	Fluted Disc 318mm Dia.	-
21	45662	M10 x 30 CSK Screw	-
22	60468	Cover Plate Stainless Steel	-
23	60452	Single Disc Assembly LH	-
24	60453	Single Disc Assembly RH	-
25	60454	Double Disc Assembly 125mm (5 inch)	-
25	60455	Double Disc Assembly 147.5mm (6 inch)	-
25	74052	Double Disc Assembly 175mm (7 inch)	-
26	60458	Axle Arm 125mm (5 inch)	-
26	60459	Axle Arm 147.5mm (6 inch)	-
26	74053	Axle Arm 175mm (7 inch)	-

# 'Renovator AS5300' Tine & Boot Assembly

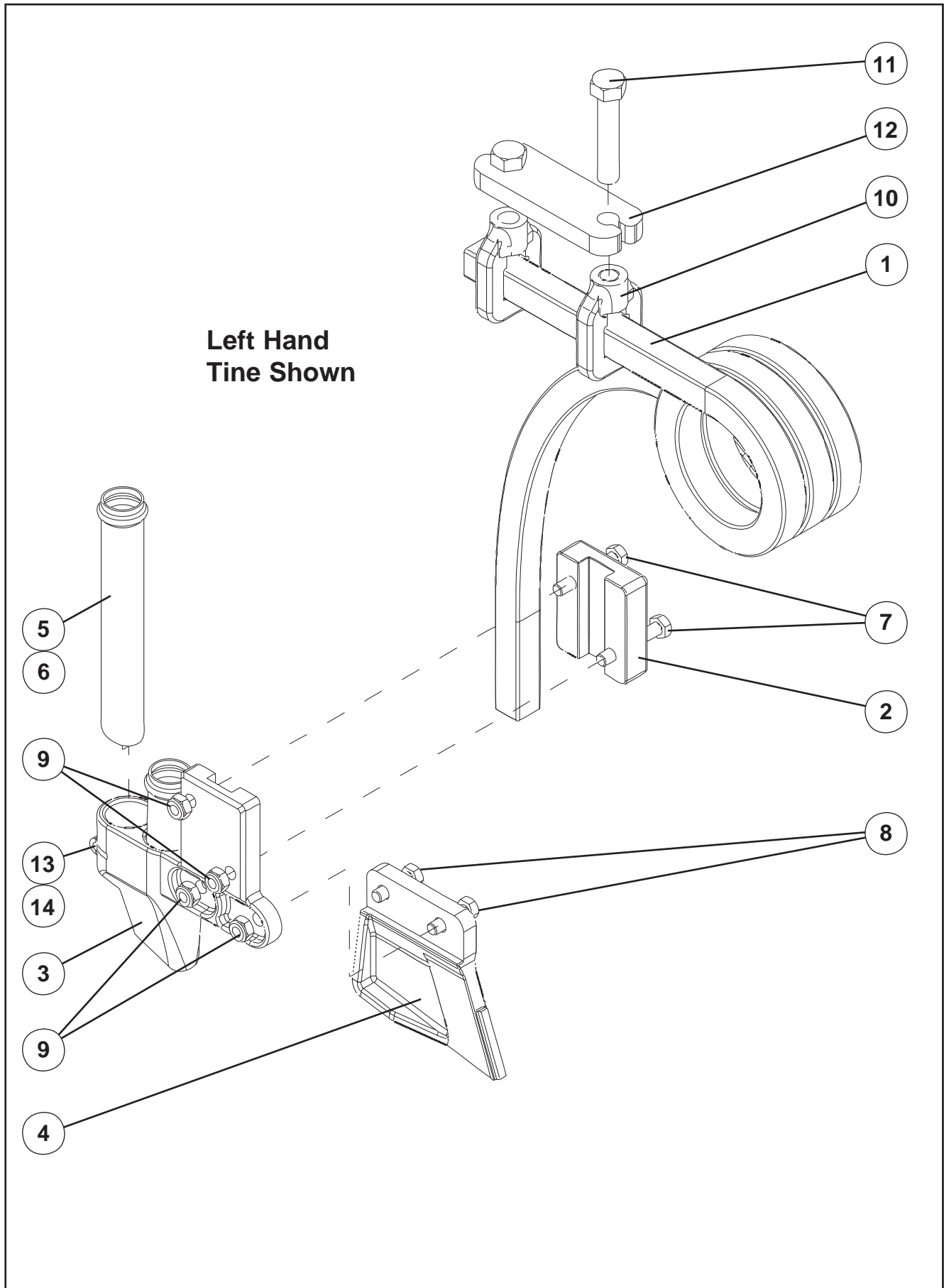

# ‘Renovator AS5300’ Tine & Boot Assembly

ITEM	PART No.	DESCRIPTION	QTY
1	21413	LH Coil Tine	-
1	21414	RH Coil Tine	-
2	26848	LH Inverted Tee Clamp	-
3	25615	RH Inverted Tee Clamp	-
4	26849	Cast Inverted Tee Point	-
5	25608ss	Fertilizer Tube: Straight, Stainless Steel	-
6	25613ss	Fertilizer Tube: Angle, Stainless Steel	-
7	45010	M10 x 65 Bolt, Class 8.8	-
8	45003	M10 x 30 Bolt, Class 8.8	-
9	45138	M10 Nyloc Nut	-
10	21691	Tine Clamp Casting	-
11	45466	M16 x 80 (4.6) Zinc Plated Bolt	-
12	21690	75 x 75 RHS Clamp Plate	-
13	45413	M8 x 35 Bolt (dual box)	-
14	45137	M8 Nyloc Nut (dual box)	-
15	43691	Feed Hose 38mm	per mtr

--	--	--	--

# 'Renovator AS5300' Tine Harrow Parts

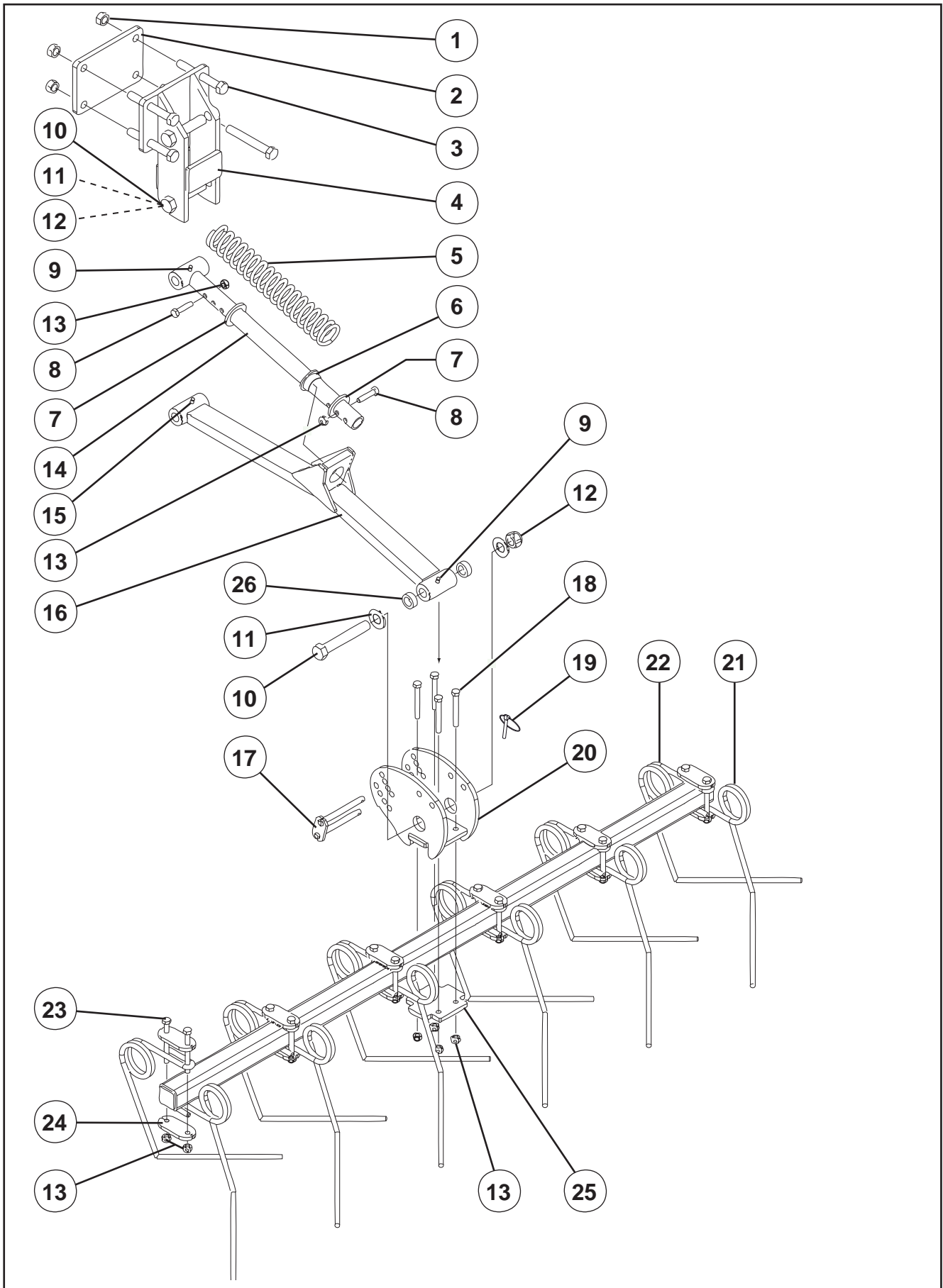

# ‘Renovator AS5300’ Tine Harrow Parts

ITEM	PART No.	DESCRIPTION	QTY
1	45140	M16 Nyloc Nut	-
2	60428	Strut Bolt Plate	-
3	45050	M16 X 120 Gr 8.8 bolt Z/P	-
4	60426	Tine Harrow Strut W/Assy	-
5	60437	Levelling Harrow Spring	-
6	60438	Guiding bar Bush	-
7	60439	Guiding Spacer	-
8	45006	M10 X 45 Gr 8.8 bolt Z/P	-
9	43118	Grease Nipple Straight	-
10	45073	M20 X 130 Gr 8.8 bolt Z/P	-
11	45161	M20 HD flat washer Z/P	-
12	45141	M20 Nyloc Nut	-
13	45138	M10 Nyloc Nut	-
14	60435	Guidingbar W/assy	-
15	43120	Grease Nipple 90°	-
16	60430	Swinging Arm W/Assy	-
17	60441	Levelling Harrow Pivot Pin W/Assy	-
18	45013	M10 x 80 Gr 8.8 bolt Z/P	-
19	43675	1/4" x 1 1/2" Lynch Pin	-
20	60421	Tine Harrow Bracket	-
21	60255	Levelling Harrow Tine -LH	-
22	60256	Levelling Harrow Tine -RH	-
23	45016	M10 X 100 Gr8.8 Bolt Z/P	-
24	60422P#	Double Retaining Plate Profile	-
25	60420	Harrow Bar Clamp Plate	-
26	60440	Swinging Bracket Spacer	-

# 'Renovator AS5300' Bushes-Mainframe Wheels

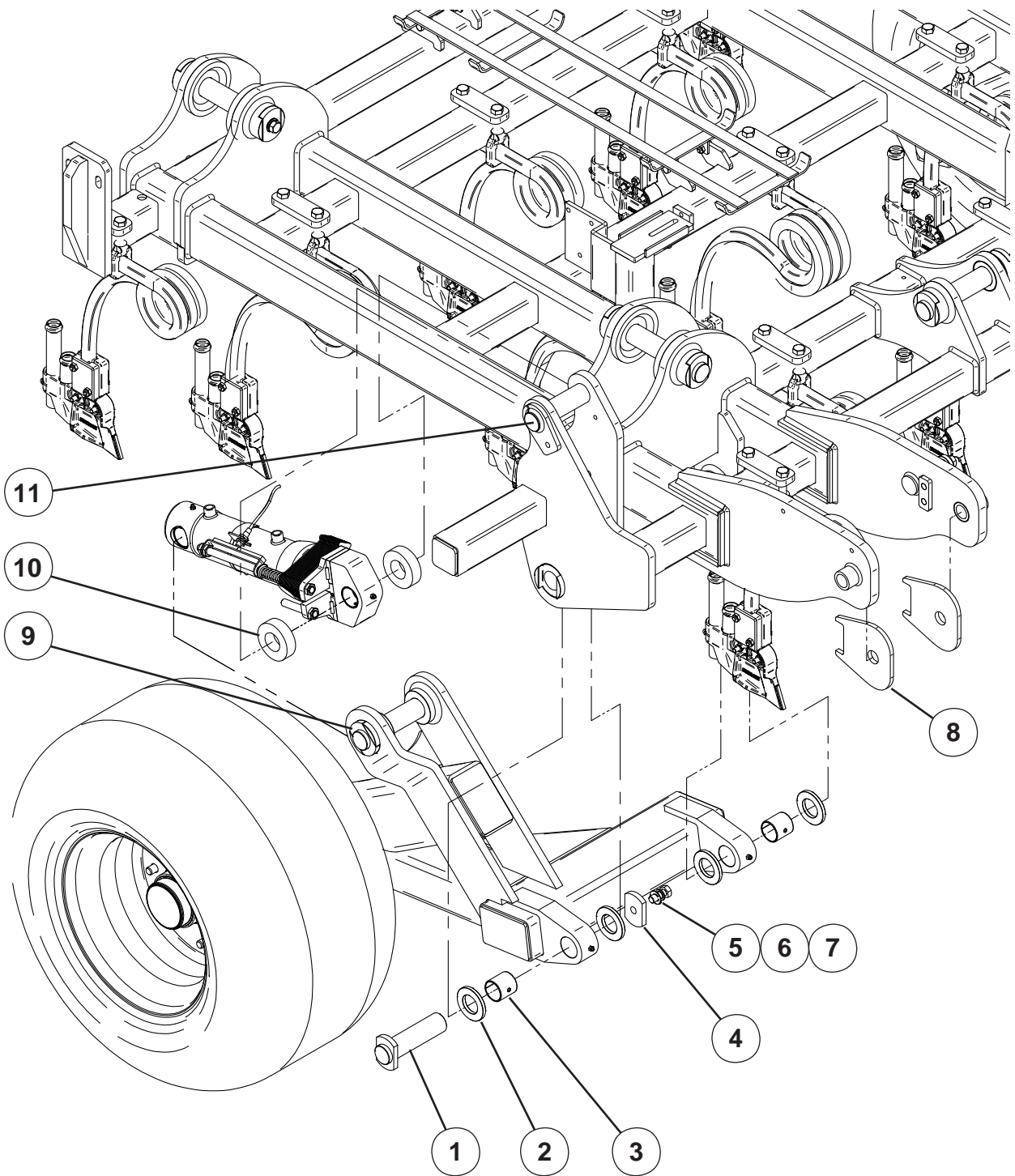

See page 58 for lift rams

# 'Renovator AS5300' Bushes-Mainframe Wheels

ITEM	PART No.	DESCRIPTION	QTY
1	72337	Pin Main Wheel Pivot W/Assy	4
2	72329	Wheel Leg Spacer	8
3	43426	Glacier Bush PM-4540SY	4
4	72335	Pin Cap Loose Plated	4
5	45154	M16 Light Flat Washer Z/P	4
6	45168	M16 Spring Washer Z/P	4
7	45038s	M16 x 40 Grade 8.8 Z/P S/Screw	4
8	72324	Drawbar Washer (nylon)	4
9	72357	Pin Main/Wing Whl Tail End W/Assy	2
10	72358	Pin Cap Loose	2
11	72775	Rod Eye Packer (Main Wheel)	4
12	43425	Glacier Bush PM-4530SY	4 per cyl
13	72772	Pin Main Whl Ram Hd End W/Assy	2

**Right Hand Side shown -parts count is for both sides**

# 'Renovator AS5300' Bushes-Wing Wheels

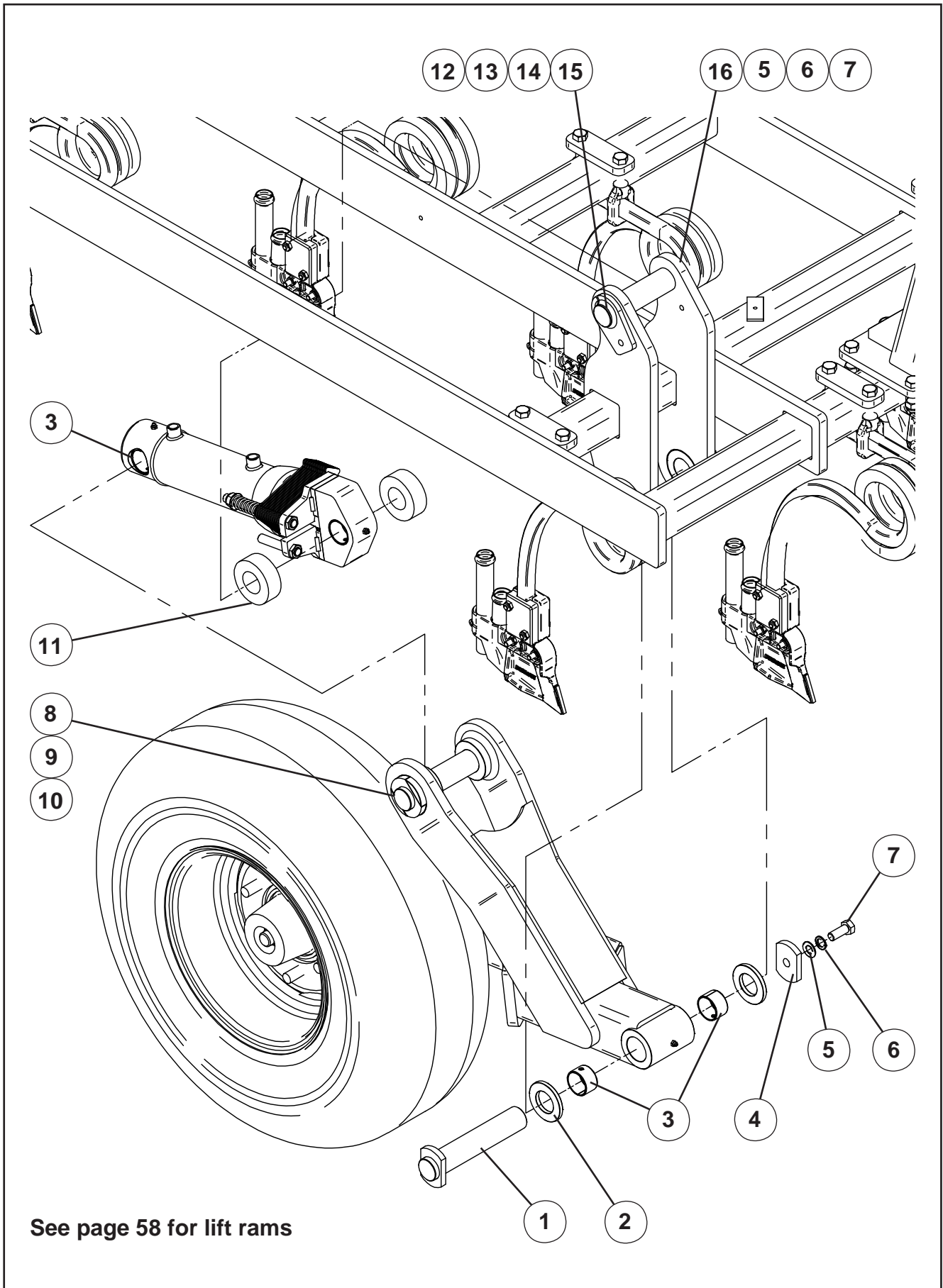



# ‘Renovator AS5300’ Bushes-Wing Wheels

ITEM	PART No.	DESCRIPTION	QTY
1	72340	Pin Wing-Wheel Pivot W/Assy	2
2	72329	Wheel Leg Spacer	4
3	43425	Glacier Bush PM-4530SY	12
4	72335	Pin Cap Loose Plated	2
5	45154	M16 Light Flat Washer Z/P	4
6	45168	M16 Spring Washer Z/P	4
7	45038s	M16 x 40 Grade 8.8 Z/P S/Screw	4
8	72357	Pin Main/Wing Whl Tail End W/Assy	2
9	72358	Pin Cap Loose	2
10	45237	M16 x 50 Csk Socket Hd Screw	2
11	72776	Rod Eye Packer (Wing Wheel)	4
12	72769	Pin Whl Ram Head End W/Assy	2
13	45153	M12 Light Flat Washer Z/P	2
14	45167	M12 Spring Washer Z/P	2
15	45019s	M12 x 30 Grade 8.8 Z/P S/Screw	2
16	72777	Pin Cap Plain	2

**Right Hand Side shown -parts count is for both sides**

# 'Renovator AS5300' Bushes-Wing Pivot

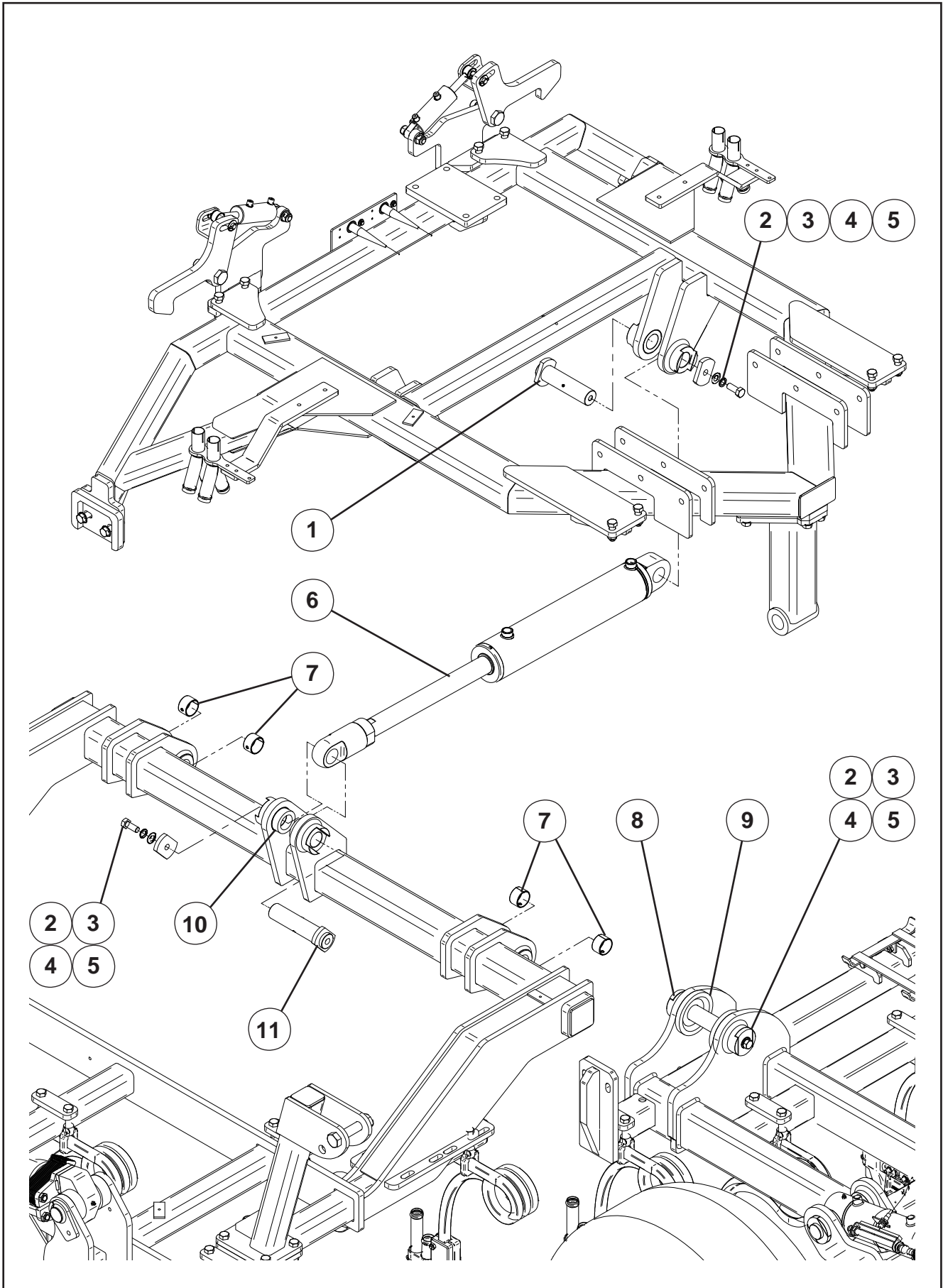

# ‘Renovator AS5300’ Bushes-Wing Pivot

ITEM	PART No.	DESCRIPTION	QTY
1	72511	Pin, Wing-Ram Tail End W/Assy	2
2	72335	Pin Cap Loose Plated	8
3	45154	M16 Light Flat Washer Z/P	8
4	45168	M16 Spring Washer Z/P	8
5	45038s	M16 x 40 Grade 8.8 Z/P S/Screw	8
6	72664	D/A Ram 4"x2"x416mm Adjustable	2
7	43425	Glacier Bush PM-4530SY	8
8	72332	Pin, Wing-Pivot W/Assy	4
9	60065	Wheel Arm Spacer	8
10	72765	Rod Eye Packer (Wing Fold)	4
11	72594	Pin, Wing-Ram Head End W/Assy	2

**Right Hand Side shown -parts count is for both sides**

# 'Renovator AS5300' Lift Rams

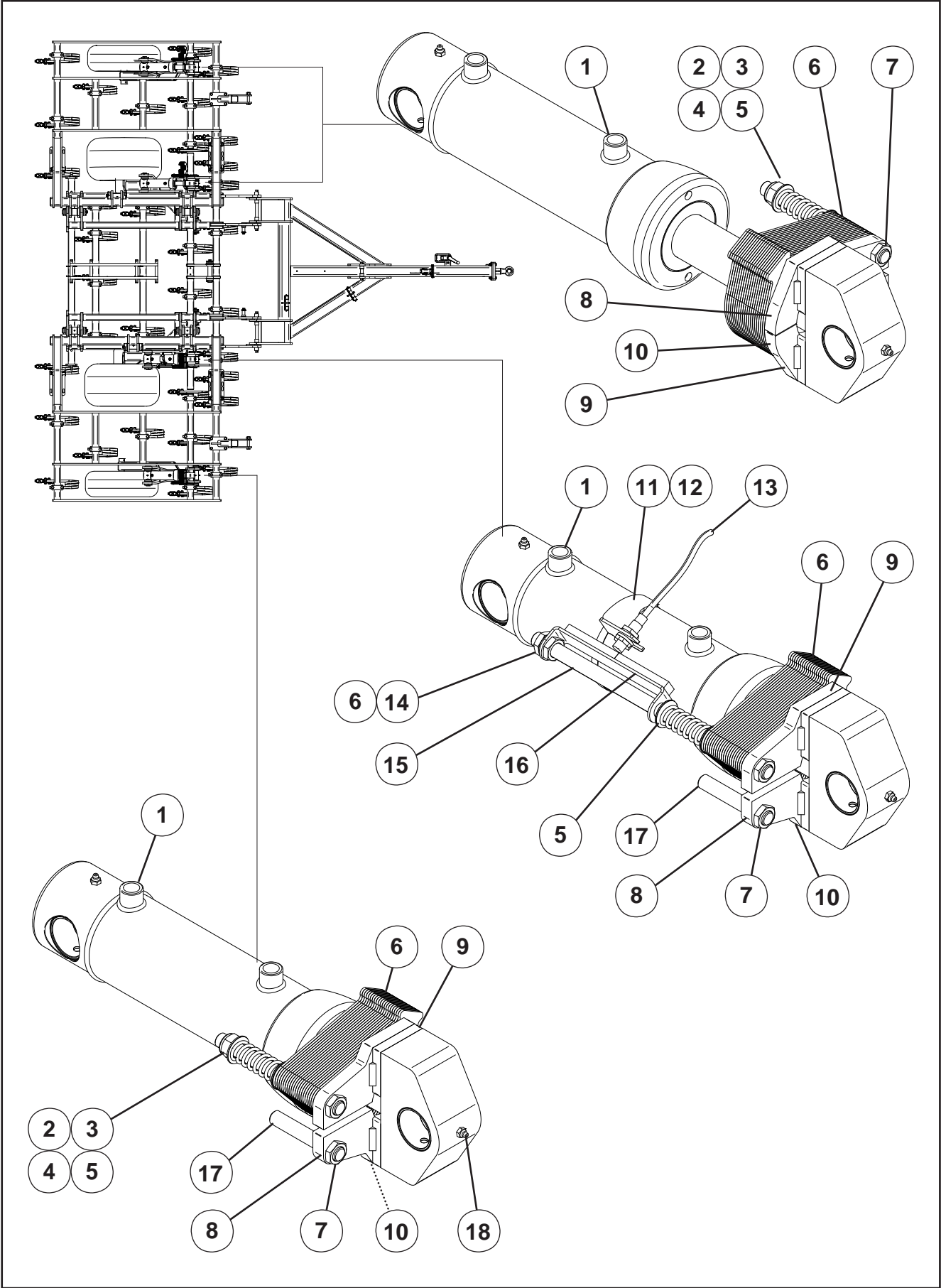

# ‘Renovator AS5300’ Lift Rams

ITEM	PART No.	DESCRIPTION	QTY
1	72670	D/A Ram 3.5x2"x 188mm 3/4 UN'O	-
2	72709	Pivot Rod Short	-
3	45140ss	M16 Nyloc Nut Stainless	-
4	45154ss	M16 Light Flat Washer Stainless	-
5	19867	Compression Spring	-
6	72703	Depth Stop Plate Profile	-
7	45119ss	M16 Stainless Hex Half Nut	-
8	72716	Pivot & Top Plate 'A' W/Assy	-
9	72715	Pivot & Top Plate 'B' W/Assy	-
10	45238	M12 x 50 Csk Socket Hd Screw	-
11	29129	Wheel Sensor Mount	-
12	44082	Hose Clamp Stainless 82-108mm	-
13	43949	Shaft Sensor c/w 2Way Amp SS	-
14	45168ss	M16 Spring Washer Stainless	-
15	72707	Pivot Rod Assembly Long	-
16	72712	Magnet Carrier Assembly	-
17	72710	Stop Rod	-
18	43118	M8 x 1.25p Straight Grease Nipple	-