

Owners Manual

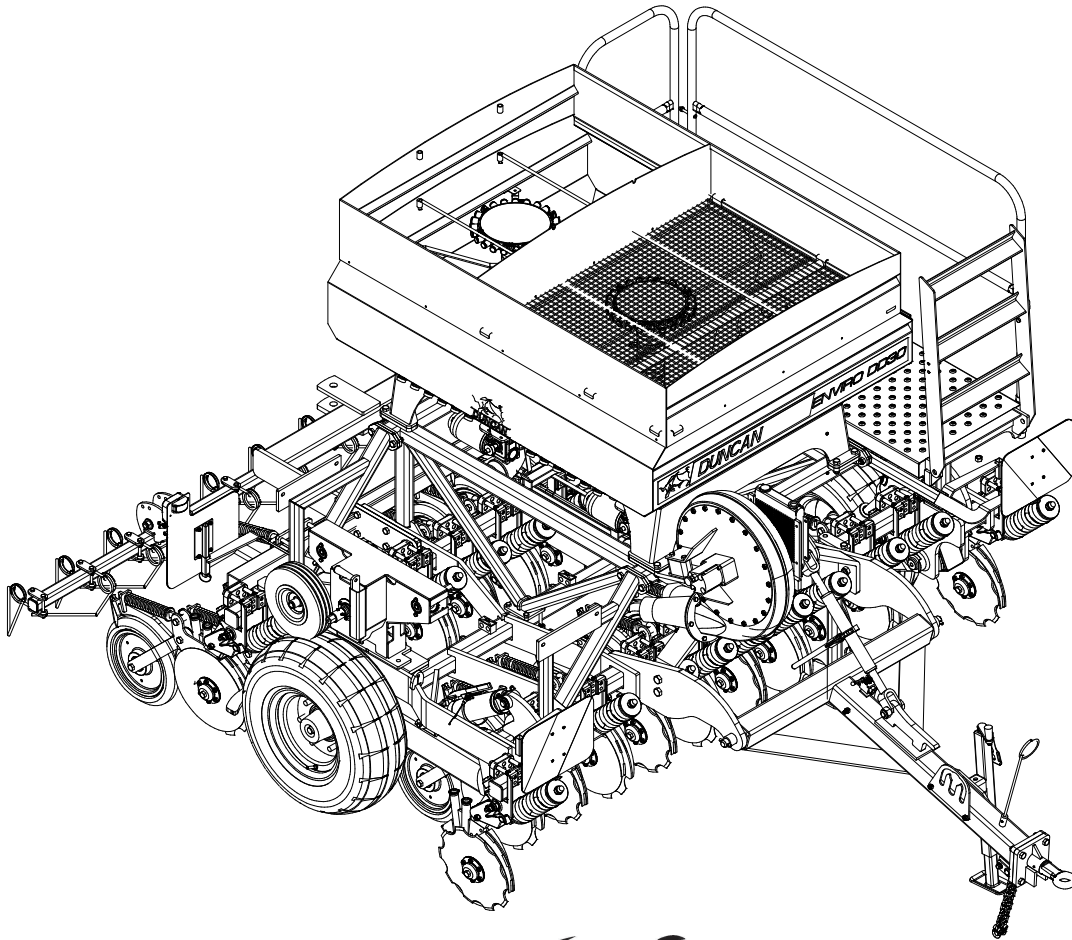

Enviro DD30 ORIGINAL INSTRUCTIONS



Built to work.

Head Office:
P.O. Box 2018
Hilton Highway, Washdyke
Timaru, New Zealand
Telephone (03) 688 2029
Facsimile (03) 688 2821

Australian Branch:
Building 2 107-117 Boundary
Road
Laverton North, Melbourne,
Victoria 3026 Australia
Telephone (03) 9369-6548
Facsimile (03) 9314-6810

**Pt. No. 67394
Issue 0922**

Enviro DD30 Contents

	Page
Introduction	2
Acquisition & Warranty	2
Disclaimer	2
Description of Machine	
Working Principle	3
Specification	
Dimensions & Capacities	5
SAFETY - General	
Safety Symbols on Machine	6
Operator Safety	7
Be Prepared for Emergencies	7
Appropriate Dress	8
Transport This Machine Safely	8
Handle Agricultural Chemicals Safely	9
Avoid High Pressure Fluids	9
Safe Work Practices	9
Practise Safe Maintenance	10
SAFETY - Machine Specific	
Hazard Points	11
Safety Decals & Safety Guards	13
Transport	14
Setup, Calibration & Operating Procedure	
Read Before Operation	15
Pre-calibration setup flowchart	16
Calibration procedure	17
Hand Crank Turns for Seed Rate Calibration .	18
Calibration Deviations	19
Sowing Chart -NORMAL seed	20
Sowing Chart -FINE seed	21
Airflow & Fan Speed	22
Operation	23
Depth Control	24
Farmscan Jackal Settings	25
Blank Page for your Calibration Notes	27
Maintenance & Care	
General	28
Lubrication Instructions	29
Maintenance Schedule	30
Storage	32
Troubleshooting/Maintenance Notes	33
Commisioning/Troubleshooting Phasing Rams	34
Parts List	
Base Machine	39
Hose Connection Colours	79
Optional Extras	82

Introduction

Acquisition & Warranty

On delivery of your new Duncan Enviro DD30 please check that the machine is not damaged. In cases of shipping damage, please ask your dealer to arrange for the appropriate claim to be lodged immediately. Assemble any parts supplied loose and inspect your machine with the aid of this manual to familiarise yourself with its features. If you have any queries ask your dealer straight away. The machine is covered by our 12 month warranty on faulty parts, subject to normal use.



Record below the serial number of your machine and keep it in a secure place to help trace the machine and assist us when you order parts.

Model:
Serial No:
Owner:
.....
.....
Delivery Date:
Dealer:
.....
.....

This Document contains the Original Operating Instructions for this machine and are verified by the Manufacturer. Signed:..... Product Development Manager
--

The Owner's Manual

Your new Duncan Enviro DD30 will give long and efficient service if given normal care and operated properly.

This owner's manual is provided so that you can become thoroughly familiar with the design of the machine and to furnish information on correct operation, adjustment and maintenance. **Only persons well acquainted with these guidelines should be allowed to use the equipment.**

A separate illustrated parts section has been provided so that if any parts are required your dealer will be able to supply them by reference to part numbers.

The manual is considered as part of your machine and must remain with the machine when it is sold.

Right and left hand references in this manual are determined by standing behind the machine and facing in the direction of travel.

Disclaimer Every effort has been made to ensure that the information in this manual was accurate and up to date at the time of going to press. Giltrap AG reserves the right to make subsequent changes to the machine, where necessary, without notification. The Company will not be responsible for any damage or consequential loss arising out of misinterpretation or failure to follow recommended procedures. Nor will it be liable for any damage caused by or arising out of modification or misuse of its product. The owner has a responsibility to protect himself and others by observing all safety information and by ensuring all operators are well acquainted with the safety information, trained in the correct use of the machine and applying safe work practices.
--



Description of Machine

The Duncan 'Enviro DD30' is a Double Disc drill. The large split hopper is mounted on a robust frame accommodating large diameter tyres. Sowing depth is controlled by adjusting the hydraulic ram as required. The quality European air metering units handle all seeds from turnip and rape through to peas and maize and permits easy calibration. The seeders are driven via a jockey wheel with individually selected high or low ranges. For transport, the drive is easily disconnected by raising the drill to its transport height.

Working Principle

The air flow and metering units are set to give the desired sowing and/or fertilizer rate. The seeding slot is opened by a unique leading scalloped disc and followed by a plain disc. Air delivers seed down the flexible tubes between the vee of each disc unit and drops into the prepared seed slot. Optional press wheels, tine harrows or following roller enhance seed to soil contact

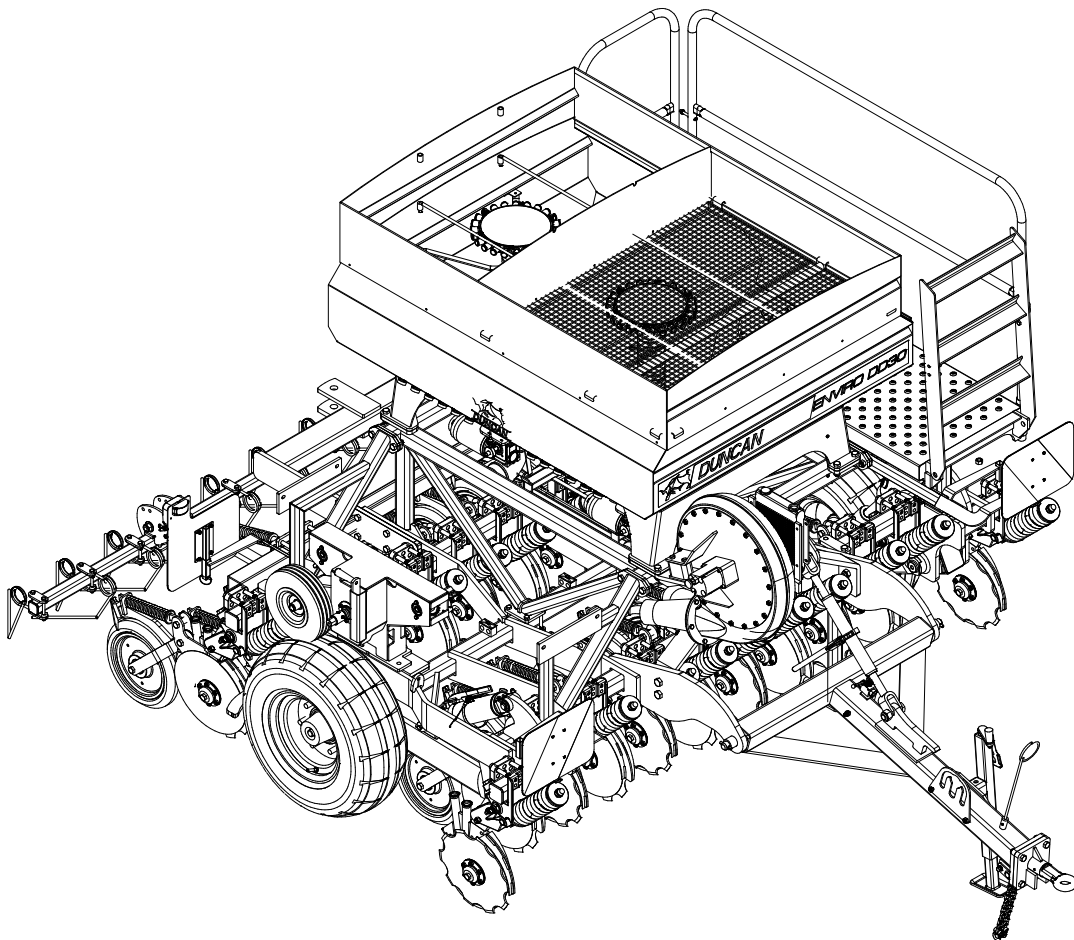

'Enviro DD30' Dimensions & Capacities

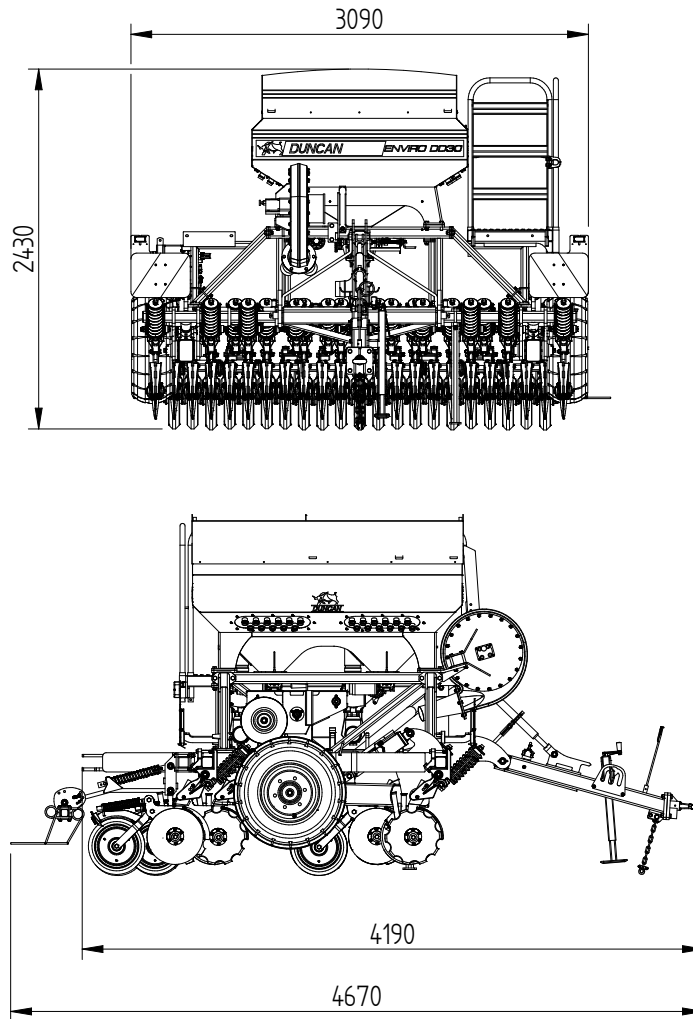

Dimensions & Capacities	23 Run
Width (over wheels /mm)	3090
Transport Height (mm)	2660
Height (Groundwheels up /mm)	2430
Machine Length (mm)	4190 (4670 including Tine Harrows)
Weight with Press Wheels fitted	2700
Tyre Size	10.0/75-15.3 (18 ply AW702)
Recommended Tyre Pressure	7 bar (101 psi)
Maximum speed (km/hr)	40 (tyre rating 138A8)
Jockey Tyre Size	410/350 x 6 x 4 ply
Jockey Tyre Pressure*	3.44 bar (50 psi) -TYRE IS FILLED WITH ANTI-PUNCTURE SEALANT*
Row Spacing	125
Effective Sowing Width	2875
Box Capacity (litres per box)	700
Tractor HP Rating range	110-180
Tractor Hydraulic Flow Capacity	At least 40 litres per minute
<i>*Pressure gauges may be damaged if they are not filtered</i>	



ATTENTION

On the machine important safety information is indicated by these symbols. These highlight general safety aspects in regard to the machine rather than specific hazards.



Do not ride or allow passengers on the machine.

Under no circumstances are passengers to be permitted on the machine while it is in operation or being transported. Any footboards and/or footsteps are provided solely for the purpose of preparing the machine for use.



Keep clothing and body extremities well clear of pinch points while the machine is operating (seeding or calibrating). Keep well clear of moving parts at all times.

These signs typically occur wherever trapping points exist. These include drive chains, sprockets, shafts, wheels, discs, pivot points, etc. Guards are provided with the machine for safety reasons (where practical without compromising machine performance). Ensure these are always fitted during operation.



Always exercise extreme caution in the vicinity of sharp edges and points.

Where possible guards are provided with the machine for safety reasons (where practical without compromising machine performance). Ensure these are always fitted during operation.



Footboards, footsteps, drawbars and other machine surfaces may be slippery when wet.

Apply extra caution in wet conditions and in the early morning when surfaces are wet.

KEEP CLEAR

Keep Clear. (It is dangerous to be in this area when the machine is operating.)

SAFETY - General

N.B. Throughout this manual important safety information is indicated by these symbols in the margin:



A prohibition should be observed under all circumstances.



A warning indicates a hazard that could cause death or injury if the warning is ignored.



A caution indicates a hazard that may cause damage to property if the caution is ignored.

This section of the manual offers general guidelines for the safe operation of machinery. It does not replace local safety regulations. These guidelines were current at the time of publication, but may be superseded by later regulations.

Giltrap AG has made every effort to highlight all risks to personnel or property. Owners and operators have a responsibility to exercise care and safe work practices at all times in the vicinity of the machine.

Owners are advised to keep up to date on safety issues and to communicate these to all users of the machine.

Contact the Occupational Safety and Health Service (OSH) for further information about general safety aspects. If you have safety concerns specifically related to this machine, contact your dealer immediately.

Operator Safety

Read this manual carefully before operating new equipment. Learn how to use this machine safely. Be thoroughly familiar with the controls and the proper use of the equipment before using it.

Take careful note of all safety instructions both in this manual and on the machine itself. Failure to comply with instructions could result in personal injury and/or damage to the machine.

Replace missing or damaged safety signs on the machine and ensure that these remain clearly visible.

It is the owner's responsibility to ensure that anyone who operates, adjusts, lubricates, maintains, cleans or uses the machine in any way has had suitable instruction and is familiar with the information in this manual (particularly with regard to safety aspects).

Operators and other users of the machine should be aware of potential hazards and operating limitations.

Be Prepared for Emergencies

Keep a first aid kit and fire extinguisher handy.

Keep emergency numbers for doctors, ambulance, hospital and fire department near your telephone.



SAFETY - General (Continued)



WARNING

Appropriate Dress

Wear close fitting clothing and avoid rings or other forms of jewellery which could become caught in the machinery.

People with long hair must have it securely fixed and confined close to the head.

Refer to local safety standards for protective clothing and recommended safety equipment.

Adequate protection, such as a face mask, should be worn if operating this machine in dry and dusty conditions.



WARNING

Transport This Machine Safely

Ensure that all linkage pins and security clips are fitted correctly. With trailing machines tow with the drawbar only, as this is the only safe towing point on the machine.

Always check that bystanders (especially children) are well clear (front and rear) before starting and moving the tractor and the machine.

Plan safe routes of travel, and be aware of power lines and other roadside hazards. Take particular care when towing implements on hillsides.

Do not ride or allow passengers on the machine.

This machine is not designed to carry passengers, and no riders are permitted.



NO RIDE

Road transport

On public roads,

- A speed of 40km/h must not be exceeded.
- Do not operate during the hours of darkness unless standard lights are fitted and clearly visible. (This also applies when visibility is limited, e.g., in foggy conditions.)

See the guidelines in the *Vehicle Dimensions and Mass Rule*, issued by the Land & Transport Safety Authority.

Avoid tip-overs

Avoid holes, ditches and obstructions which may cause the machine to tip over, especially on hillsides. Never drive near the edge of a gully or steep embankment - it might cave in. Slow down for hillsides, rough ground and sharp turns.



SAFETY - General (Continued)

Handle Agricultural Chemicals Safely

All farm chemicals should be stored, used, handled and disposed of safely and in accordance with the supplier's/manufacturer's recommendations.



Read the product label before using, noting any warnings or special cautions, including any protective clothing or equipment that may be required, ie. respirator.

Do not eat or smoke while handling sprays, fertilisers, coated seeds, etc. Afterwards, always wash your hands and face before you eat, drink, smoke, or use the toilet.



Store sprays, fertilisers, coated seeds, etc. out of reach of children and pets, and away from food and animal feeds.

Any symptoms of illness during or after using chemicals should be treated according to the supplier's/manufacturer's recommendations. If severe, **call a physician or get the patient to hospital immediately.** Keep the container and/or label for reference.

Avoid High Pressure Fluids

Avoid any contact with fluids leaking under pressure, because the fluids can penetrate the skin surface.



Any fluid which penetrates the skin, will need to be **removed immediately by a medical expert.** Seek specialist advice on this type of injury.

Relieve the pressure before disconnecting any hydraulic or other lines. Make all repairs and tighten all fittings before re-connection to pressurised fluid.

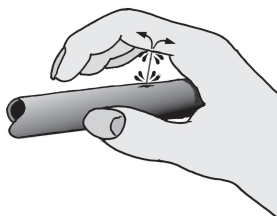

Keep your hands and body away from any pinholes or high pressure jets. Search for leaks with a piece of cardboard instead of using your hand directly.

Safe Work Practices

All farm machinery is potentially dangerous and should be treated with caution and respect.

Before starting the machine, ensure that all controls are placed in neutral and that bystanders are well clear. Check that the guards have been securely fitted and that any adjustments have been made correctly.



Where possible, disconnect or isolate the drive mechanism to the implement. Lower the machine onto the ground when not in use.

Do not operate this equipment when severe weather conditions appear imminent.

SAFETY - General (Continued)



Practice Safe Maintenance

Keep the machine in safe working condition. Routine maintenance and regular servicing will help reduce risks and prolong the life of the machine.

General Maintenance

Accidents occur most frequently during servicing and repair. The following general rules must be followed when maintaining or working with machinery:

- All operating and maintenance manuals must be read before and referred to while using or servicing any piece of equipment.
- Turn off all machinery power sources and isolate the machine before making adjustments, doing lubrication, repairs or any other maintenance on the machine.
- Ensure that the machine hydraulics are disconnected from the power source.
- Wear gloves when handling components with cutting edges, such as any ground cutting components.
- Beware of hazards created by springs under tension or compression when dismantling or maintaining the machine.
- It is recommended that you clean the machine with a water blaster or similar apparatus before commencing maintenance.

Make Sure the Machine is Well Supported

When machinery is fitted with hydraulics, do not rely on the hydraulics to support the machine. During maintenance or while making adjustments under the machine, always lock the hydraulics and support the machine securely. Place blocks or other stable supports under elevated parts before working on these.



Electrical Maintenance

Disconnect the electrical supply from the tractor before doing any electrical maintenance.



Welding

With electronic equipment in modern tractors it is advisable to disconnect the machine from the tractor, or at least disconnect the alternator and battery before attempting any welding.



Use Only Genuine Spare Parts

Unauthorised modifications or non-genuine spare parts may be hazardous and impair the safe operation and working life of the machine.

Excess lubricants must be disposed of safely so as not to become a hazard.

SAFETY - Machine Specific

This section of the manual gives specific guidelines for the safe operation of the Enviro DD30.

These guidelines were current at the time of publication, but may be superseded by later circumstances. They do not necessarily cover every possible hazard and must be read in conjunction with the **SAFETY - General** section (Page 7 to 10).

Hazard Points on the Enviro DD30

The lists below are not all-inclusive and serve only to highlight the more obvious areas of risk.



The decals attached to the machine are a general reminder that there are hazardous areas on the machine, rather than specifically highlighting all possible hazards.

For decal locations on machine, refer Page 13.



No Ride

Passengers are not permitted anywhere on the machine.



Pinch Points/Moving Parts

Hazardous areas include:

- Drive chains.
- Sprockets between the drive wheel, the transfer shaft and the gearbox (RH side).
- Sprockets between the gearbox and the box shafts (RH side).
- Agitator drive units (LH side).
- Agitator shaft inside the boxes.
- Seeder units, box shaft and shaft connectors.
- Wheel legs and main frame assemblies
- Between discs and other sub-assembly parts (where fitted).
- Finger tine assemblies (where fitted).
- Hydraulic Fan.



**Slippery
When
Wet**

KEEP CLEAR

Slippery When Wet

Hazardous areas include:

- Footboards and footstep.
- All smooth surfaces on the frame structure.

Keep Clear

Hazardous areas include:

- Between the tractor and Enviro DD30.
- Immediately adjacent to the Enviro DD30 side.

SAFETY - Machine Specific (Continued)



Hazard Points on the Enviro DD30 (Continued)

For guard locations on machine, refer Page 13.



Transport

The two wheels located at the sides of the machine are for the purpose of controlling sowing depth. These are also used to support the machine weight during transport (while linked to the tractor).

Important - Refer to safety cautions in the **Transport** section, page 14 of the manual. Ensure that all linkage pins and security clips are fitted correctly.

Maintenance

Refer Page 32 for reference to the **Maintenance and Care** section of the manual.

Lubrication

Refer Page 33 for reference to the **Maintenance and Care** section of the manual.

SAFETY - Machine Specific (Continued)

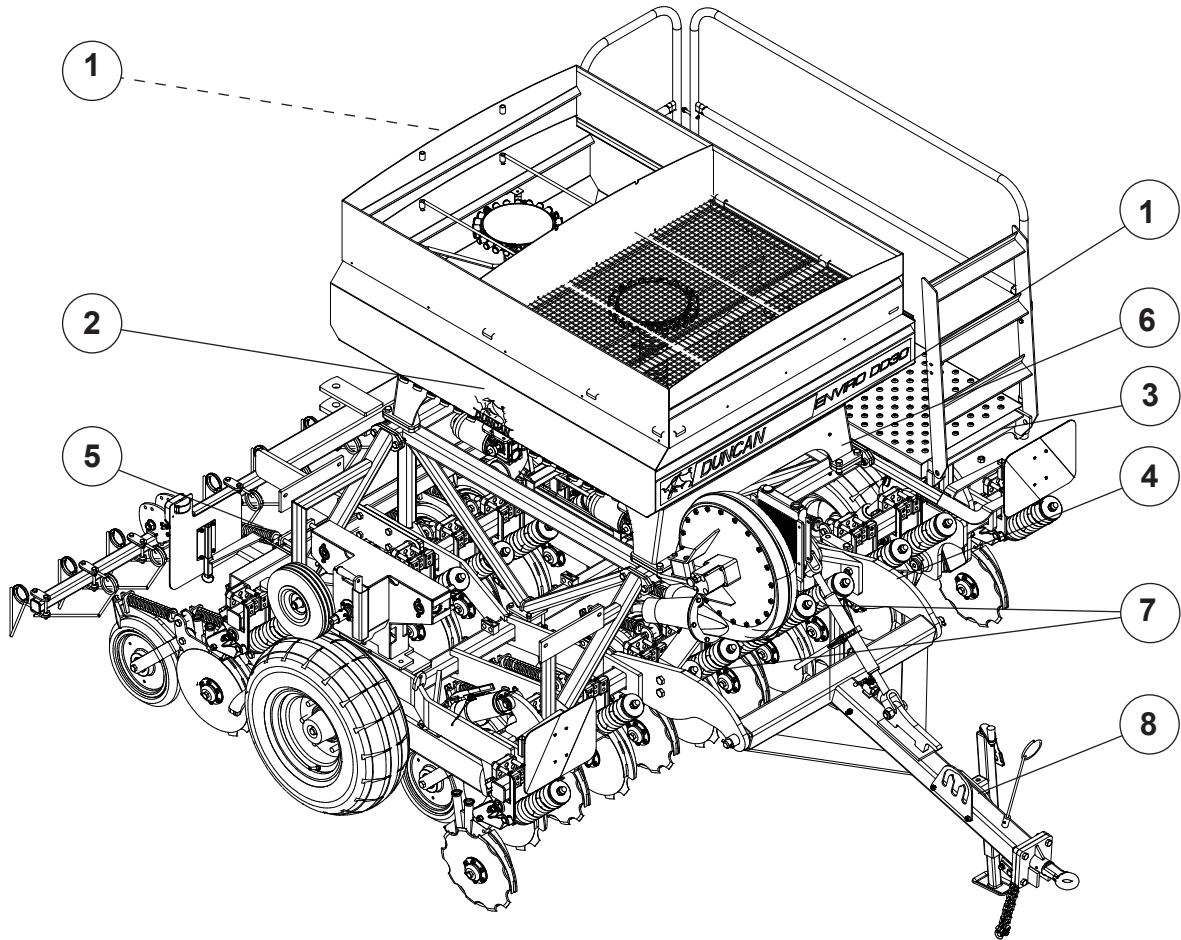

Item	Decal/Guard	Pt. No.	Qty
1	'No Ride'	43900	3
2	'Pinch Point/Moving Parts'	43901	5
3	'Slippery When Wet'	43902	2
4	'Keep Clear'	43904	2
5	Jockey Drive Swing Guard	25745	1
6	'40 km/hr'	43912	2
7	'Lift Point'	14389	2
8	'Hose Connection Colours'	72818	1

'Enviro DD30' Transport

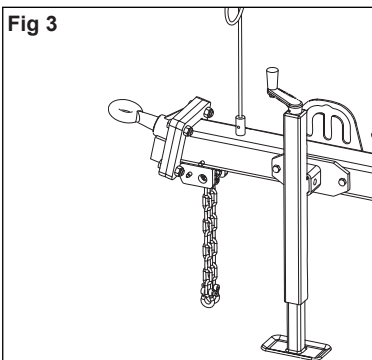
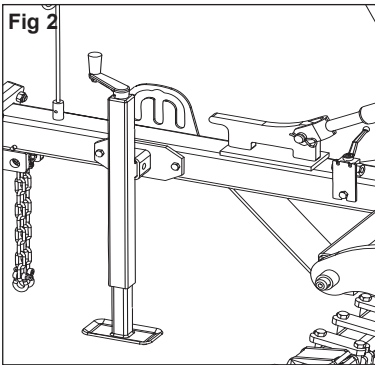
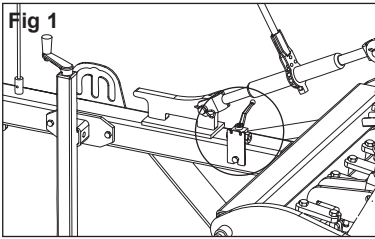

Transport

1 Raise the drill into the transport position and hold at the full extent of the rams for a few seconds to allow cylinders to rephase/equalise.

2 **Important** - To avoid machine damage due to drill lowering during transport, always close the hydraulic valve on the drawbar. Move the handle to a position at 90° to the hydraulic line as shown in Fig 1. This applies to the drawbar and disc opener hydraulic valves where fitted.

3 Locate jack stand in transport position, if fitted. Refer Fig 2.

4 Ensure lighting and oversize warning requirements meet recommendations published by the local Land Transport Authority or equivalent.

5 **Maximum towing speed 40 km/hr.**
For countries other than New Zealand other speed restrictions may apply, please refer to your local transport authority.

Ensure towing vehicle requirements are adequate for the towed vehicle e.g. mass, brakes. Refer to recommendations published by the local Land Transport Authority or equivalent.

Braking when towing can cause the load to jackknife. Use extra care when towing in adverse conditions such as mud, inclines and sharp bends.

Lower towing speeds are recommended on farm roads/tracks and where one wheel is on or over a road verge.

6 **Attach safety chains to tractor.** Refer Fig 3. Safety chains must be crossed over underneath the coupling and attached to the towing vehicle. The attachment points must be as close as practical to the towing coupling and one each side. The towbar on the towing vehicle must be rated for the towed mass. **Do not remove or replace the safety chains provided with any other than those specified in the parts manual.**

Note: The safety chains are provided with sufficient length to cater for all towing vehicles. Safety chains must be shortened by cutting off excess length so that if the coupling fails the drawbar will not hit the ground.

7 If the machine is fitted with row markers or other vertical extensions, check clearance under power lines en route.

8 **Important** - For greater disc opener ground clearance, adjust the ram or turnbuckle on the disc opener unit so they are at maximum height, and/or extend the drawbar ram or turnbuckle to level the machine chassis.



'Enviro DD30' Read Before Operation

Components Referred to in the Pre-Calibration Setup and Calibration Process

The following pages describe how to set the machine up for calibration, the calibration process and subsequent adjustments to obtain the desired seed and/or fertilizer output.

Terms and words used in those instructions are shown below:-

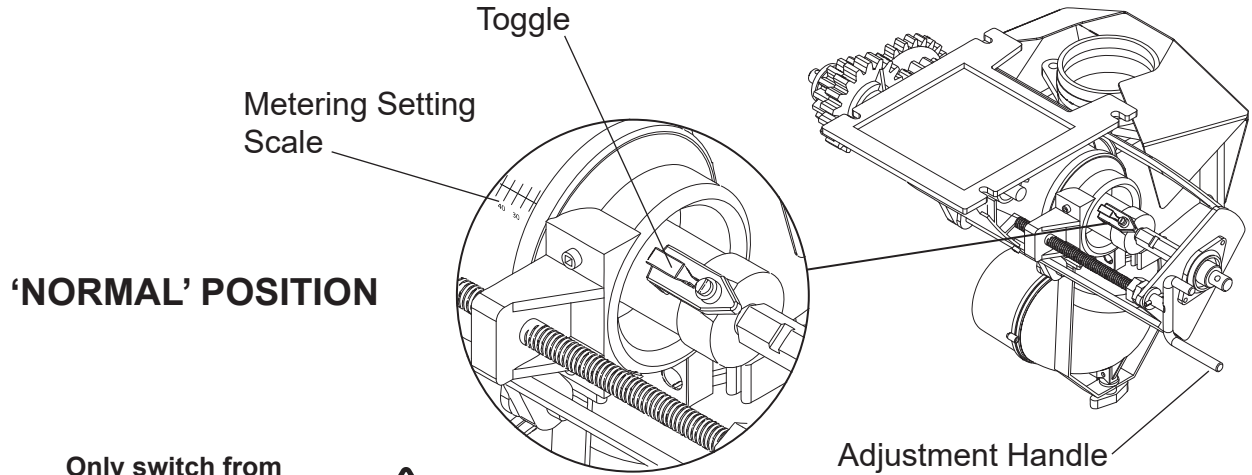

Only switch from normal to fine seed if the seed hopper is empty

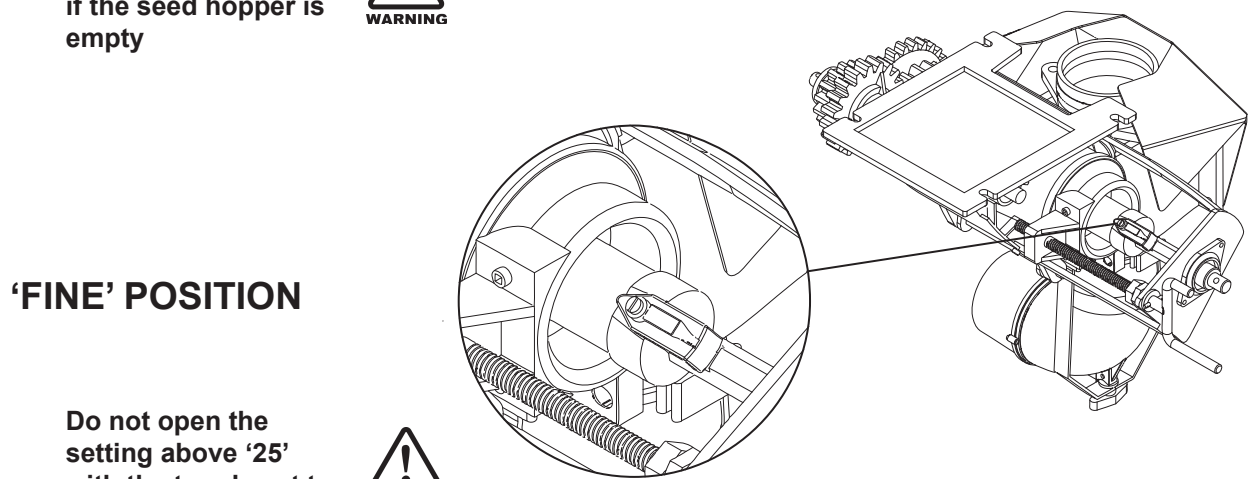

Do not open the setting above '25' with the toggle set to 'fine' as the adjuster will break.

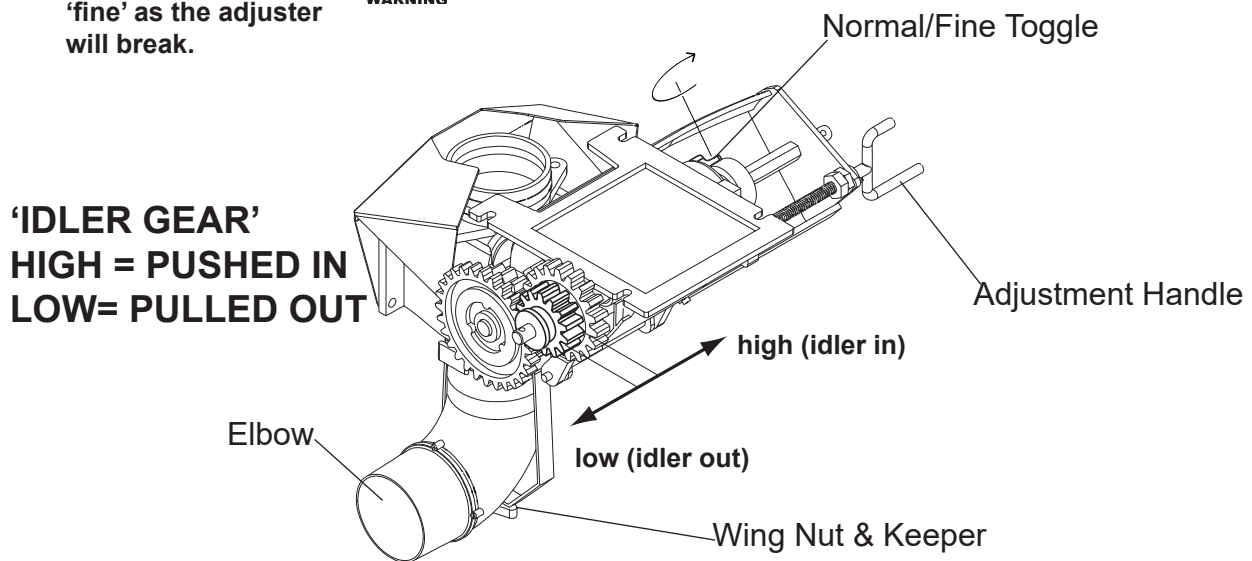

'Enviro DD30' Pre-Calibration Setup

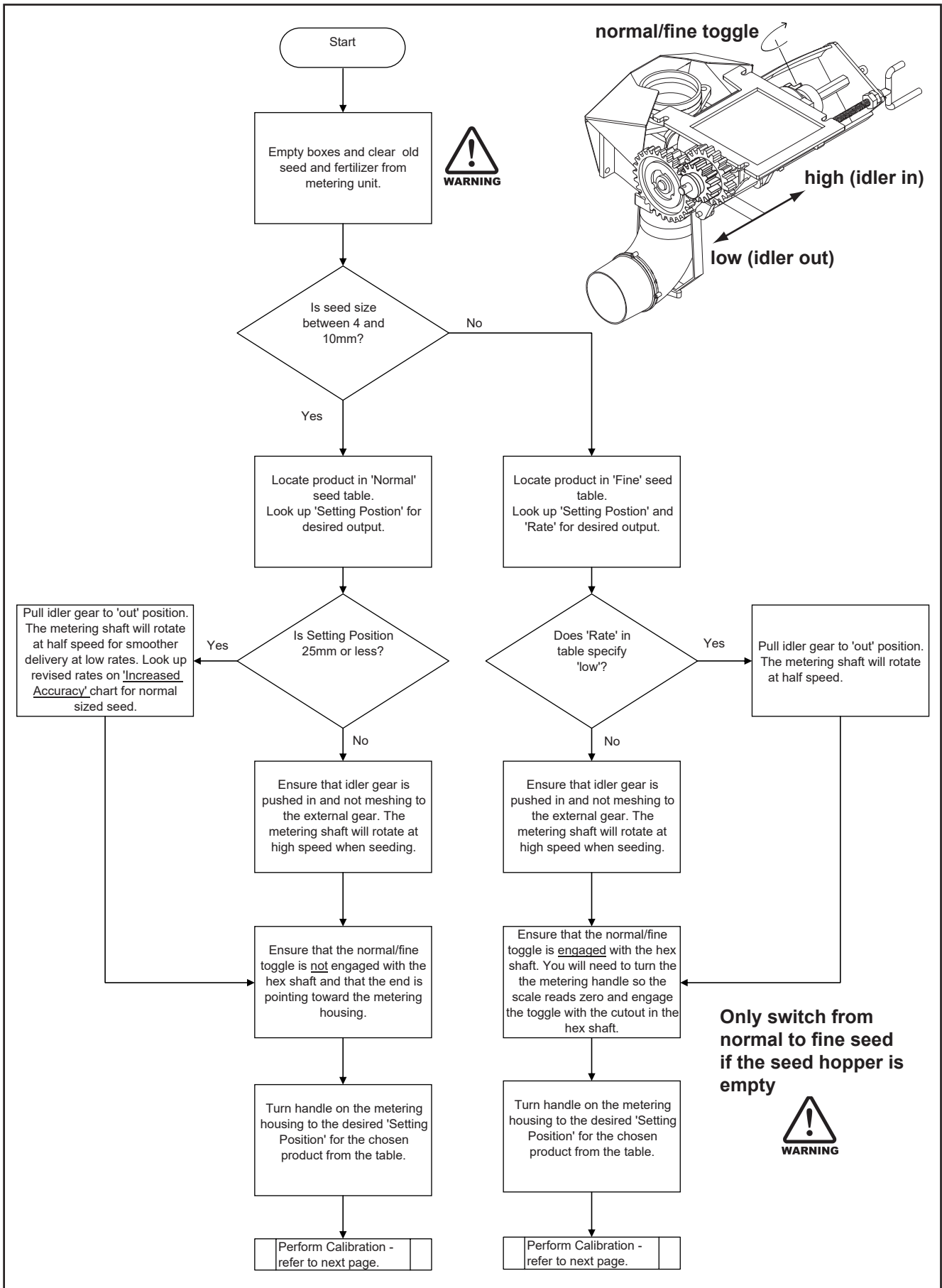

'Enviro DD30' Calibration

Seed Calibration

The calibration test should be done to confirm the settings of the required seed rate and is done with the drill stationary and level with the fan off.



The metering units must be set prior to filling with seed.

Seed Calibration Procedures

- 1 Ensure that the metering unit is free from debris. Close the trap-door.
- 2 Fill the appropriate bin. A minimum depth of 300mm is required for calibration with normal seeds.
- 3 Release the elbows from under the metering housings by unscrewing the wing nut and swinging the keeper out of the way. Move the elbow to one side.
- 4 Unhook the calibration tray from the rear of the machine, locate it on the guides and slide the tray under the bin outlets.
- 5 The bins are calibrated one-at-a-time; on the drive pedestal (outboard) end, remove the lynch pin and disconnect the unused driveshaft. Attach the end to the dummy shaft provided on the pedestal.
- 6 Place the crank handle over the hexagonal drive dog turn anti-clockwise until the seed flows consistently..To ensure complete filling of the seed unit continue turning the crank until an even flow of seed is coming out of the seeder units, then empty into the seedbox. The drill is now ready for calibration.
- 8 Turn the crank handle anti-clockwise 32 turns - this represents 1/40th Hectare

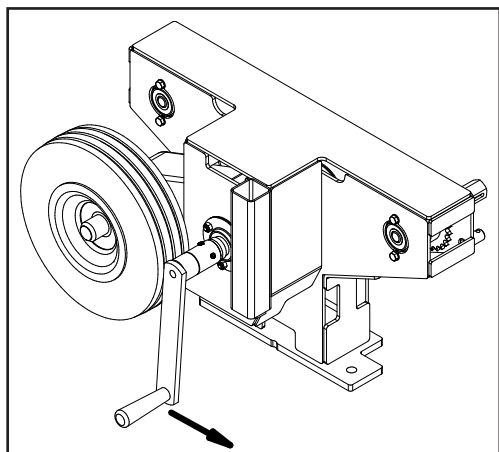

Note The Calibration is usually done for 1/40th Hectare. For very small seed rates or when using inaccurate scales (i.e. unable to measure to the nearest gram) the calculation based on 1/10th hectare should be used. In this case the turn the crank handle 128 turns.

Scales must be accurate to 2 grams as any error will be multiplied by either 10 or 40 giving inaccurate calibration results.

For $\frac{1}{40}$ Hectare (250m²) Calibration
Seed Rate = Actual Seed Collected (kg) x 40

For $\frac{1}{10}$ Hectare (1000m²) Calibration
Seed Rate = Actual Seed Collected (kg) x 10

'Enviro DD30' Calibration

Hand Crank Turns for Seed Rate Calibration

Machine Size	Row Spacing(mm)	Sowing Width (m)	Turns for 1/40 Hectare	Turns for 1/10 Hectare
23 Run	125	2.875	32	128

- 9 Weigh the seed collected during the test in kilograms.

Caution: Scales must be accurate to 2 grams, as any error will be multiplied by either 10 or 40, giving inaccurate calibration results.

- 10 Calculate the seed rate by multiplying the kgs previously collected x 40 (1/40th ha method) or x 10 (1/10th ha method) depending on the requirement.

The seed rate should be correct. Large differences should be checked by recalibration. If there are still large errors, empty the seed bin, check the metering housings for wear or damage and start again from the pre-calibration setup.

- 11 Small errors, due to seed coatings or seed sizes can be corrected by adjusting the metering unit as follows:-

>Check and write down the **actual metering setting** on the metering unit.

>Write down the **actual seeding rate** that you calculated.

>Write down the **required seeding rate** (the number you *expected* from the calculation).

Calculate the error and correction as follows:-

$$\text{error} = \frac{\text{difference between actual and required seeding rate}}{\text{required seeding rate}}$$

$$\text{correction} = \text{error} \times \text{actual seeding rate}$$

- 12 If the **actual seeding rate** that you calculated is **smaller than** the **required seeding rate** then **increase** the metering setting by the **correction** amount.

- 13 Conversely, **reduce** the **metering setting** by the **correction** amount if the observed or **actual seeding rate** is **more than** the **required seeding rate**.

Care must be taken when the metering setting is significantly reduced as the unit can be damaged. If any resistance is felt, rotate the jockey wheel when adjusting the settings down. If the toggle is set to 'fine' and the settings needs to be reduced very low, empty the bin and start again.



- 14 Recalibrate from step 6.

- 15 Where a coated seed is used it is advisable to check the calibration after 1 hectare as dressings can tend to create a coating on the seed metering wheels thus changing the the flowing properties of the seed which in turn alters the seed rate.

'Enviro DD30' Calibration

Wheel Slip Deviations

It is always possible with rubber tyred drills in extreme ground conditions to get wheel slip. Not normally a problem with cleated type tyres in good condition, but more so in the arable situation with the less aggressive tread patterns. The result: large differences between the calibration test and the actual sowing rate, obviously less seed deposited than required.

To check number of crank turns for calibration

Should you require to check this in a practical way proceed as follows:

For an area of 250m² (1/40 Hectare), the travel distance for your machine is 87 metres.

Place the crank handle over the hexagonal drive dog on the gearbox.

Move the machine forward over the measured distance, counting the number of turns of the crank handle as you go.

Using this number of crank turns repeat the calibration.

'Enviro DD30' Sowing Chart Normal

NORMAL SEED (toggle NORMAL, Butterfly Valve Settings shown below and on page 22)

PRODUCT	SPECIFIC GRAVITY (kg/l)	Setting Position> RATE*	*10*	*15*	*20*	*25*	30	35	40	45	50	55	60	65	70	75	80	85	90	95	100	105	110
Wheat	0.8	high	34	51	69	86	104	122	140	157	174	192	210	228	246	264	281	298	316	335	352	370	387
Oats	0.5	high	24	35	47	59	71	82	94	106	118	130	141	153	165	177	189	200	212	224	236	248	260
Barley	0.7	high	32	48	64	79	95	111	127	143	159	174	190	206	222	238	253	268	284	300	316	332	348
Ryecorn	0.7	high	33	49	66	83	100	117	134	151	168	184	200	217	235	252	269	286	302	319	337	354	371
Peas	0.8	high	21	40	59	78	97	117	136	155	174	194	213	232	251	270	289	309	328	347	366	385	404
Grass	0.4	high		18	26	34	42	50															
Pasture Mix	-	high		18	26	34	42	50															
DAP	1.0	high	39	58	77	97	116	135	155	174	193	213	232	251	270	290	309	328	348	367	386	406	425
Superphosphate	1.3	high	34	70	109	138	171	204	235	266	303	336	366	390	421	451	489	524	558	586	622	660	

INCREASED ACCURACY FOR SETTING POSITION<25mm (toggle NORMAL, Butterfly Valve Settings shown below and on page 22)

PRODUCT	SPECIFIC GRAVITY (kg/l)	Setting Position> RATE*	*10*	*15*	*20*	*25*	30
Wheat	0.8	low	17	25.5	34.5	43	52
Oats	0.5	low	12	17.5	23.5	29.5	35.5
Barley	0.7	low	16	24	32	39.5	47.5
Ryecorn	0.7	low	16.5	24.5	33	41.5	50
Peas	0.8	low	10.5	20	29.5	39	48.5
Grass	0.4	low	-	9	13	17	21
Pasture Mix	-	low	-	9	13	17	21

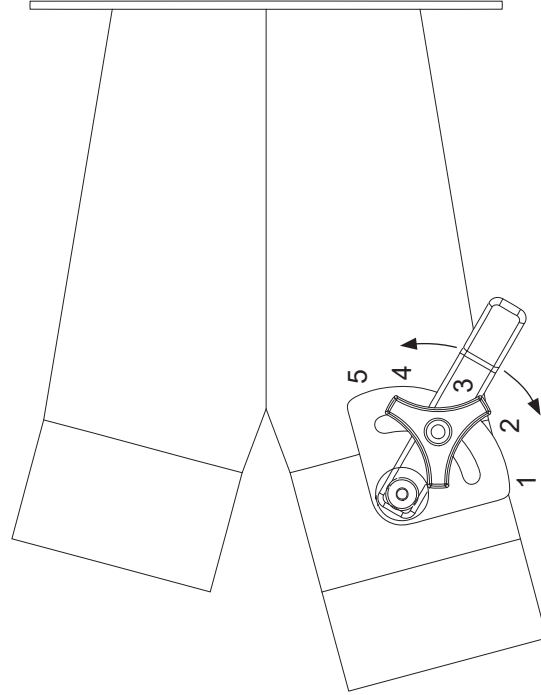

Box contents		Butterfly Position (affects rear box)	Fan Speed/rpm*
FRONT	REAR		
seed (Normal)	seed (Normal)	open - 5	3000
seed (Normal)	seed (Fine)	closed - 1	3000
Fertilizer	seed (Normal)	closed - 2	3000 to 3500
Fertilizer	seed (Fine)	closed - 1	3000 to 3500

*MAXIMUM PERMISSIBLE SPEED 4000 RPM

'Enviro DD30' Sowing Chart Fine

FINE SEED (toggle 'FINE', Butterfly Valve Settings shown below and on page 22)												
PRODUCT	SPECIFIC GRAVITY (kg/l)	Setting Position>	2.5	5	7.5	10	12.5	15	17.5	20	22.5	25
			RATE ONCE SET DO NOT REDUCE/CLOSE WITH SEED IN BIN**									
Lucerne (Alfalfa)	0.8	low	1.1	3.1	4.6	6.5	7.9	9.3	11.3	13.0	14.4	15.5
Turnip	0.7	low	1.1	2.3	3.4	4.6	5.7	6.9	8.0	9.1	10.3	11.4
Kale	0.7	low	1.1	2.3	3.4	4.6	5.7	6.9	8.0	9.1	10.3	11.4
Swedes	0.7	low	1.1	2.3	3.4	4.6	5.7	6.9	8.0	9.1	10.3	11.4
Canola/Rape	0.7	low	1.1	2.3	3.4	4.6	5.7	6.9	8.0	9.1	10.3	11.4
White Clover	0.8	low	1.2	2.7	4.3	6.0	7.7	9.0	10.7	12.0	13.3	13.8
Red Clover	0.8	low	1.2	2.7	4.3	6.0	7.7	9.0	10.7	12.0	13.3	13.8
Grass	0.4	low			1.4	2.6	3.6	4.6	5.6	6.6	7.5	8.1
Millet	0.6	low		1.1	2.3	3.6	4.8	5.8	6.8	8.2	9.2	10.3
Grain Sorghum	0.6	low		0.3	2.8	6.0	7.5	8.5	10.5	12.2	13.7	15.7
Forage Sorghum	0.6	low		0.3	2.8	6.0	7.5	8.5	10.5	12.2	13.7	15.7
Chicory	0.5	low	0.6	1.8	2.9	4.1	5.1	6.2	7.5	8.6	9.5	10.4
Lucerne (Alfalfa)	0.8	high	2.2	6.1	9.2	13.0	15.9	18.7	22.6	25.9	28.8	31.0
Turnip	0.7	high	2.2	4.6	6.8	9.1	11.4	13.7	15.9	18.2	20.5	22.8
Kale	0.7	high	2.2	4.6	6.8	9.1	11.4	13.7	15.9	18.2	20.5	22.8
Swedes	0.7	high	2.2	4.6	6.8	9.1	11.4	13.7	15.9	18.2	20.5	22.8
Canola/Rape	0.7	high	2.2	4.6	6.8	9.1	11.4	13.7	15.9	18.2	20.5	22.8
White Clover	0.8	high	2.3	5.3	8.6	12.0	15.3	18.0	21.3	24.0	26.6	27.5
Red Clover	0.8	high	2.3	5.3	8.6	12.0	15.3	18.0	21.3	24.0	26.6	27.5
Grass	0.4	high			2.8	5.2	7.2	9.2	11.2	13.2	15.0	16.2
Millet	0.6	high		2.2	4.6	7.3	9.6	11.6	13.6	16.4	18.4	20.6
Grain Sorghum	0.6	high		0.6	5.6	12.0	15.0	17.0	21.0	24.4	27.4	31.4
Forage Sorghum	0.6	high		0.6	5.6	12.0	15.0	17.0	21.0	24.4	27.4	31.4
Chicory	0.5	high	1.2	3.7	5.8	8.2	10.1	12.5	15.1	17.2	19.1	20.8

**Setting may only be reduced by a large amount if unit is turning or bin and metering device clear of product else damage will occur. Do not open the setting above '25' with the toggle set to 'fine' as the adjuster will break.

Box contents		Butterfly Position (affects rear box)	Fan Speed/rpm*
FRONT	REAR		
seed (Normal)	seed (Normal)	open - 5	3000
seed (Normal)	seed (Fine)	closed - 1	3000
Fertilizer	seed (Normal)	closed -2	3000 to 3500
Fertilizer	seed (Fine)	closed - 1	3000 to 3500

* MAXIMUM PERMISSABLE FAN SPEED 4000 RPM

'Enviro DD30' Airflow & Fan Speed

Airflow and Fan Settings

1. Hydraulic Fan -connect the hoses in the following order:

First - connect Zero pressure Case Drain 3/8" hose (1/2" BSP Female QR) to hydraulic reservoir * Hose marked with short RED wrap.



Second -connect Motor Return 3/4" hose (3/4" BSP Female QR) to tractor high flow low pressure return port. Hose marked with medium length RED wrap.

Finally - connect High Pressure Motor Feed 1/2" hose (1/2" BSP Male QR) to tractor remote. Hose marked with long RED wrap.

Disconnect in the reverse order to prevent motor seal damage.

*The tractor hydraulic reservoir or free drain connection must have zero backpressure.



2. A higher fan speed is usually required to correctly deliver high rate or heavier product such as fertilizer from the front box. The airflow to the rear box is reduced by setting the butterfly valve to the appropriate position as shown in the table. If this is not done the seed delivered to the disc units from the rear box may well bounce out of the seed slot.

The following table shows box fill combinations, butterfly position and recommended fan speeds for normal/fine seeds and fertilizer:-

Box contents		Butterfly Position (affects rear box)	Fan Speed/rpm*
FRONT	REAR		
seed (Normal)	seed (Normal)	open - 5	3000
seed (Normal)	seed (Fine)	closed - 1	3000
Fertilizer	seed (Normal)	closed -2	3000 to 3500
Fertilizer	seed (Fine)	closed - 1	3000 to 3500

* MAXIMUM
PERMISSABLE
FAN SPEED
4000 RPM

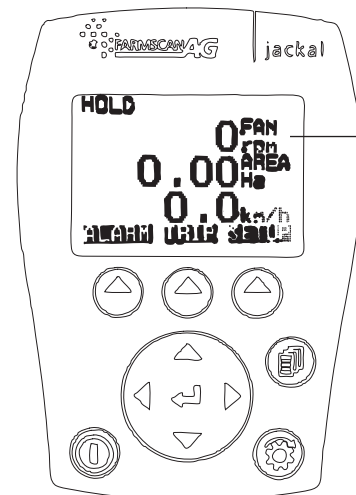
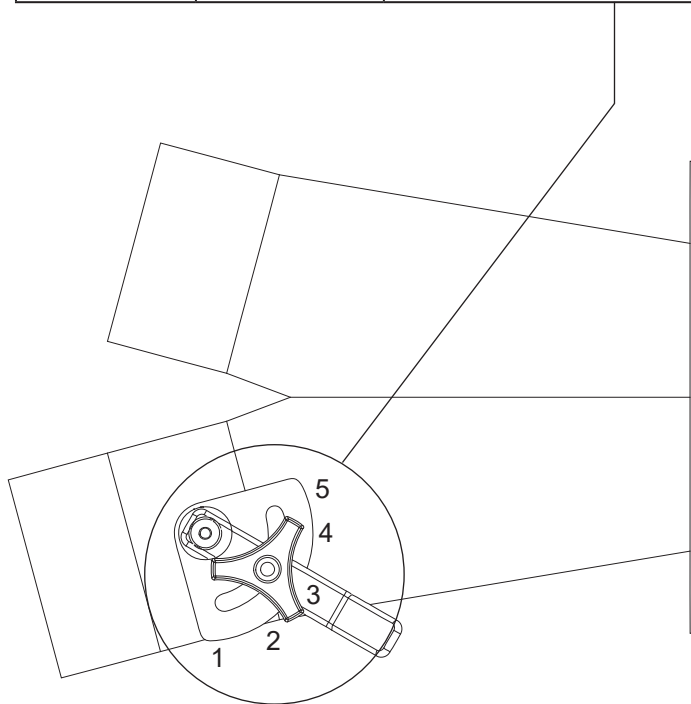

The Fan Speed shown on the Farmscan Jackal is for illustrative purposes only. Refer to the table for the correct setting.

Operation

General Operation Guidelines

1 Hydraulic Fan -connect the hoses in the following order:

First - connect Zero pressure Case Drain 3/8" hose (1/2" BSP Female QR) to hydraulic reservoir * Hose marked with short RED wrap.



Second -connect Motor Return 3/4" hose (3/4" BSP Female QR) to tractor high flow low pressure return port. Hose marked with medium length RED wrap.

**Finally - connect High Pressure Motor feed 1/2" hose (1/2" BSP Male QR) to tractor remote. Hose marked with long RED wrap.
Disconnect in the reverse order to prevent motor seal damage.**

***The tractor hydraulic reservoir or free drain connection must have zero backpressure.**



- 2 Use a sufficiently powerful tractor which is heavy enough to tow the drill safely.
- 3 Operate the drill at a speed of 6-12 km/hr (4-8 mph).
In stony and uneven ground conditions a lower speed is more appropriate
- 4 Check that the drill is level during calibration and while seeding.
- 5 Check tyre pressure before seeding. Refer page 5.
- 6 Double check seed rates before seeding.
- 7 Raise the drill out of the ground when making any turns.
- 8 Raise the drill out of the ground before backing up.
- 9 After prolonged storage, check to see that all drive mechanisms and hydraulic equipment are functioning correctly. Check that the seed tubes are not perished or blocked.

Sowing Speed

Typical travel speeds when sowing range from 6-12 km/hr in good conditions. In stoney and uneven ground conditions a lower speed is recommended to minimise rapid part deterioration. Sowing too fast can result in:

- 1 Poor contour following and uneven sowing depth.
- 2 Impact damage to:
 - a Ground engaging components.
 - b Bearings, housings & axles.
 - c Fasteners & structural components.
- 3 More extreme conditions will result in greater vibration and uneven seed flow at low seeding rates.

'Enviro DD30' General Operation

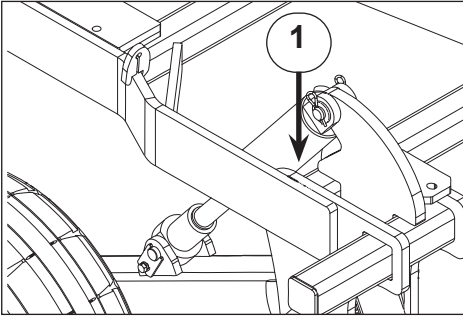

Sowing Depth Control

The sowing depth is dependent on:

- 1 The wheel height in relation to the chassis
- 2 Tyre pressure
- 3 Ground condition i.e. hard or soft

The wheel height in relation to the chassis is controlled using the threaded depth adjustment collar (1) on the non-drive wheel leg ram. The rams are phasing and only require depth stops under the master cylinder.

Level Drill

Use the drawbar turnbuckle or ram to tilt the drill so it is sitting level. An adjustment may be required after a short period of use because the paint wears off the discs and the discs sharpen which in turn improves the penetration abilities.

Ensure that the front and rear rows are at an even depth.

Transport Position

When in the transport position the hydraulic cylinders are fully extended. In this position the cylinders fully equalise by allowing oil to bypass the master cylinder piston. It is recommended to raise the drill into the transport position when turning at headlands or regularly to counteract the effects of oil leakage past the piston and ensure cylinder rods are equally extended and minimise variations in sowing depth.

'Enviro DD30' Jackal Areameter

Farmscan Jackal v3.5 Settings Setup

The unit supplied with the machine has already been setup at the factory to the settings shown below.

Refer to the manual supplied with your Farmscan Jackal kit for additional information and operation.

Farmscan Jackal v3.5 Factory Setup for Enviro DD30 Air

Refer to the Farmscan Jackal v3.5 manual.

Input 1 - Three wire proximity sensor for 'Area/Speed Wheel' measurement taken from shaft on drive pedestal.

The white 'signal' lead is connected to input A1.

Input 1 Edit	
m/pulse	
Auto Set:	
Target:0.000m	
Meas.pulses:	0
Manual Ratio:	2.750000
NEXT	EDIT

Other Settings	
Implement Width:	2.875 m
Extern.Run/Hold:	Disabled
Alarm Beep:2	
NEXT	EDIT

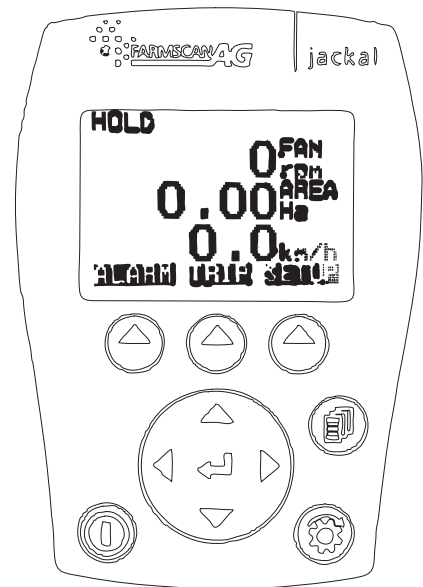

Input 2 - Three wire proximity sensor for fan 'Tachometer' measurement. The white 'signal' lead is connected to input A2.

Input 2 Edit	
pulse/rev	
Auto Set:	
Target:0.000rev	
Meas.pulses:	0
Manual Ratio:	1.000000
NEXT	EDIT

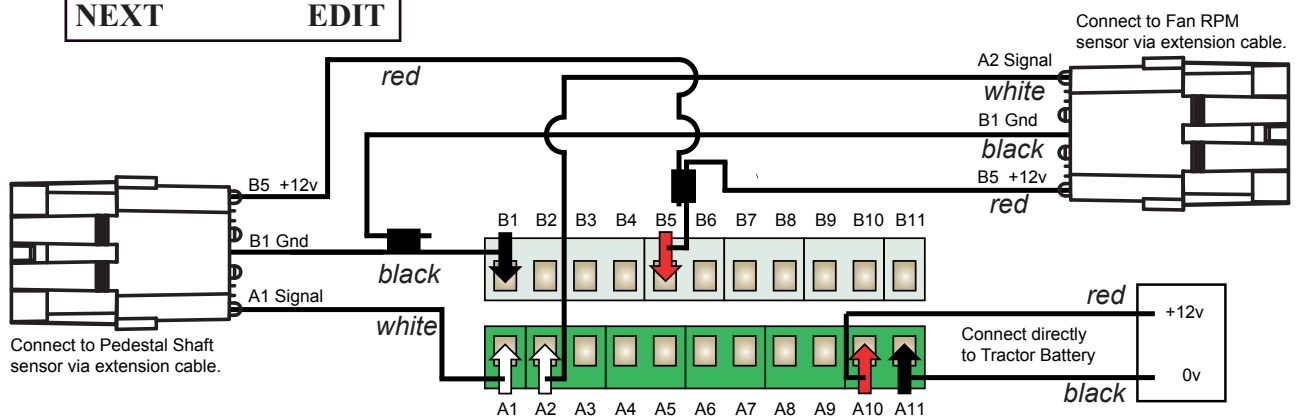

Refer to the Farmscan manual if you want to make additional sensor connections.

It is advisable, as with all things electronic, to have a backup of your totals. We suggest you record these on a daily basis in a notebook or diary.

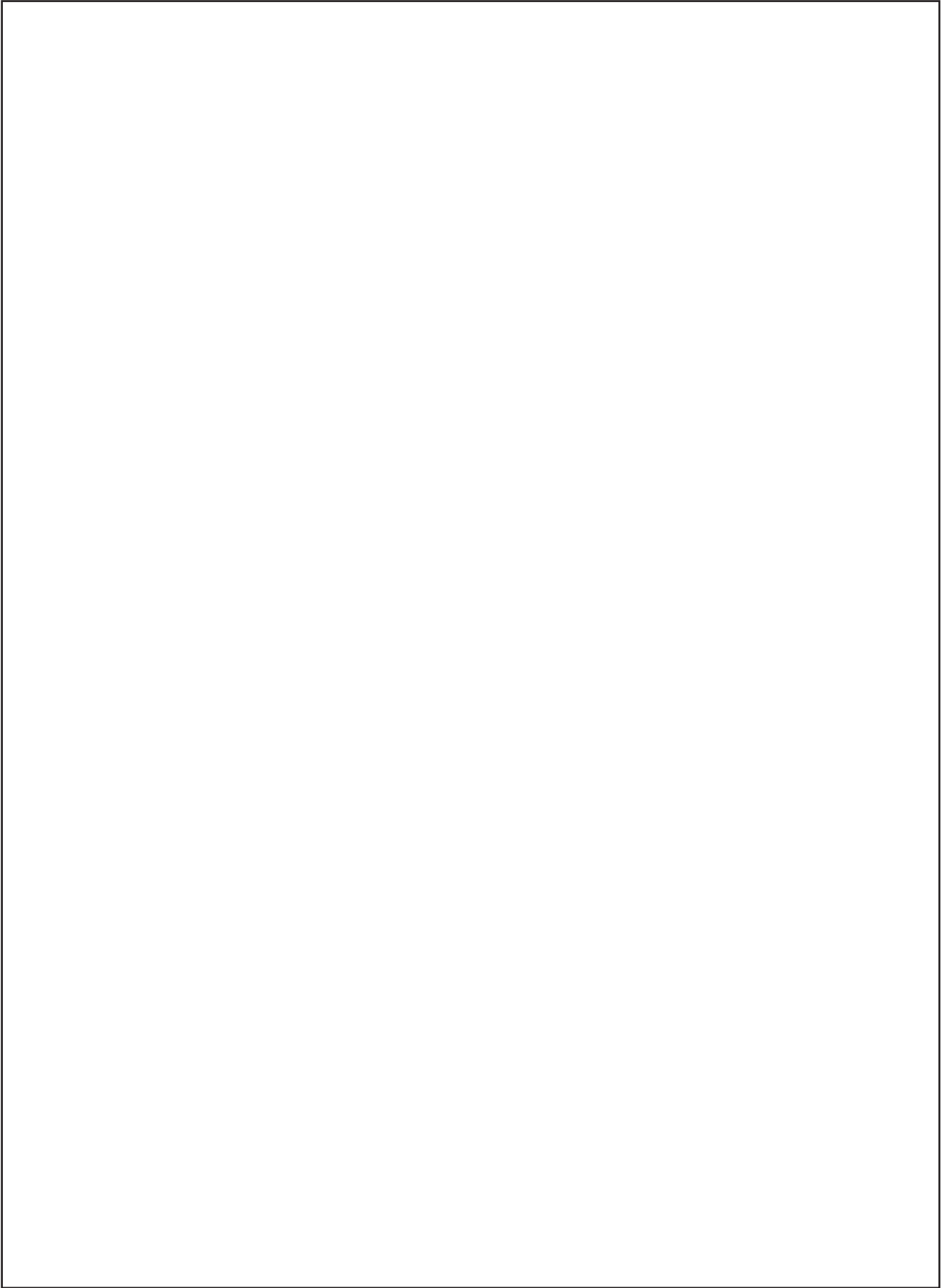

'Enviro DD30' Maintenance & Care

Maintenance & Care

General Safety and Accident Prevention Advice



- 1 Make sure that if the tractor remains attached to the drill that the ignition key is removed.
- 2 During maintenance the drill should be supported in such a manner that if hydraulic failure was to occur the machine would still be adequately supported.
- 3 Wear gloves when handling components with cutting edges such as worn discs etc...
- 4 Disconnect the electrical supply from the tractor before doing any electrical maintenance.
- 5 Refer to safety sections for more safety information.

General Cautionary Maintenance Advice



- 1 **Electric Welding** - With the electronic equipment in modern tractors it is advisable to completely disconnect the implement from the tractor, or at the very least disconnect the alternator before attempting any welding.
- 2 **Hydraulics** - Ensure hydraulic couplings (male & female) are clean before connecting. Dirty couplings will result in hydraulic oil contamination and hydraulic cylinder seal/poppet valve damage and bore scores. This in turn will result in oil leakage past the piston seals.

No filter is fitted to the hydraulic system. If hydraulic fittings and oil supply are not going to be kept clean it is recommended that a filter be fitted to prevent hydraulic cylinder damage.
- 3 **Water Blasting** - Water blasting, steam cleaning or other pressurised cleaning processes can force dirt etc. into undesirable places that may cause damage or rapid part wear to items such as bearings, seals, chains, bushes etc. Caution must be exercised.

'Enviro DD30' Maintenance & Care

Maintenance & Care - Lubrication Instructions

Precautions with Grease

Greases should not be mixed as the structure may be weakened by the mixes of different types of thickener, which may cause softening and loss of grease from the bearings by running out.



Your new Duncan Enviro DD30 Seed Drill will give long and efficient service if given normal care and maintained properly.

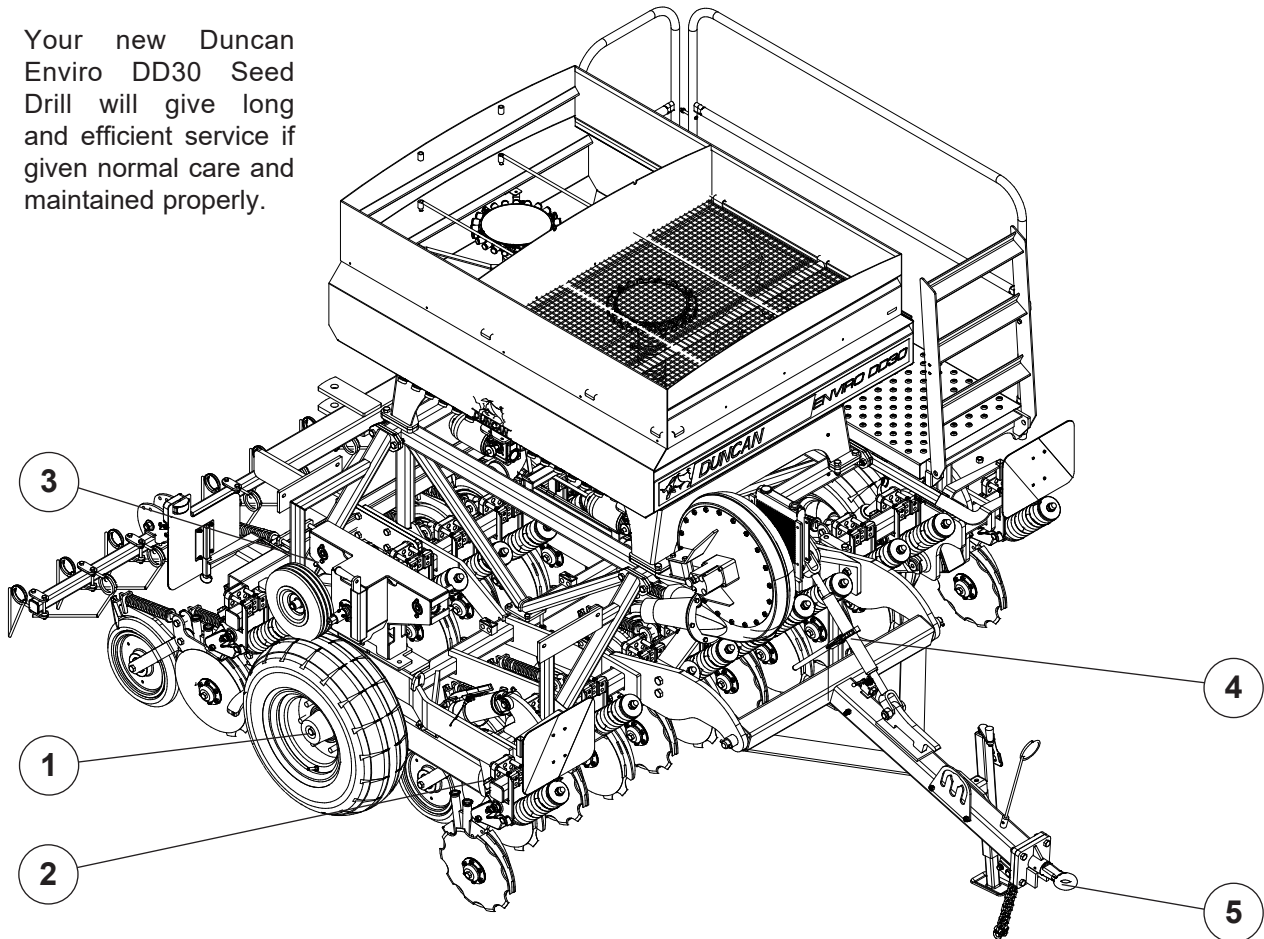

Lubrication Chart

Item	Components	Lubricant	Frequency
1	Wheel Bearings	Castrol LMX Grease	Annually
2	Wheel Leg Pivots	Castrol LMX Grease	Weekly
3	Drive Chains	Suitable Roller Chain Lubricant	See Maintenance Schedule
4	Turnbuckle	Castrol LMX Grease	Monthly
5	Coupling	Castrol LMX Grease	Weekly

* The lubrication frequencies are only a guide. Actual frequency will be dependent on extent of use and ground conditions.

'Enviro DD30' Maintenance & Care

Maintenance & Care - Lubrication Instructions

Components	Daily (or after 20Ha)	Weekly (or after 75Ha)	Pre Season (or 500 Ha)
Depth Adjustment Collar	•	•	•
Wheel Nuts	•	•	•
Pivot Pin Fasteners		•	•
Coupling & Safety Chains		•	•
Roller Chains		•	•
Hydraulics (Oil Leaks)		•	•
Tyre Pressures (58psi /4.0 bar)		•	•
Bolted Connections			•

Maintenance Schedule

(Refer also to Summary Chart, above)

1 Bolted Connections

All bolted connections of the machine should be checked after the first 3 to 5 hours of operation and retightened if necessary and thereafter at regular intervals. It is suggested that this is done every 500 hectares or annually, whichever occurs first.

2 Drive Chains

All drive chains should first be checked after every 20 hours of operation and thereafter weekly or after 75Ha of operation as follows:-

The metering units of the seed drill are driven via driveshafts and roller chains from the drive wheel. Cleaning of the roller chains is recommended after long periods of operation. Remove the chain, wash in kerosene and then dip them in heated grease or oil or spray them with a suitable commercial roller chain lubricant. Do not heat the black plastic chain tensioners; just wash in kerosene and refit. The lubricant on the chain will transfer to the tensioner in use.

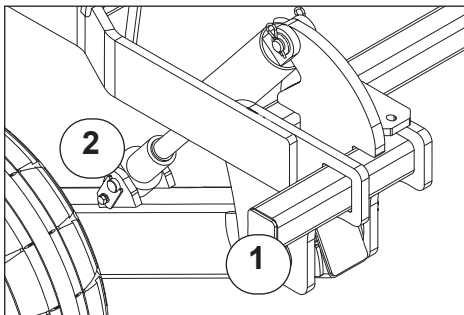

4 Wheel Arm Pivots

Wheel arm pivots must be greased regularly (weekly or after every 75Ha) to provide lubrication and flush out any dirt. (1).

5. Depth Adjustment Collar

Grease the depth adjustment collar (2) regularly to ensure it does not seize up. Also check for dirt buildup around the ram shaft seals to ensure seal damage does not occur. Refer Fig 26

'Enviro DD30' Maintenance & Care

Maintenance Schedule (continued)

6 Framework

The framework structure should be inspected annually for defects, i.e., cracks in members or welded connections. The framework should be cleaned prior to the inspection.

7 Metering Units

Ensure that the metering units are clean and that the rubber sealing lip is not damaged. The sealing lip is located along the base of the trap door hinge. A damaged sealing lip can cause seed delivery problems.

8 Fan Hydraulic Motor

Hydraulic Fan -connect the hoses in the following order:

First - connect Zero pressure Case Drain 3/8" hose (1/2" BSP Female QR) to hydraulic reservoir *
Hose marked with short RED wrap.

Second -connect Motor Return 3/4" hose (3/4" BSP Female QR) to tractor high flow low pressure return port.
Hose marked with medium length RED wrap.

Finally - connect High Pressure Motor Feed 1/2" hose (1/2" BSP Male QR) to tractor remote.
Hose marked with long RED wrap.

Disconnect in the reverse order to prevent motor seal damage.

*The tractor hydraulic reservoir or free drain connection must have zero backpressure.

'Enviro DD30' Maintenance & Care

Maintenance & Care (Continued)

Preparing the Machine for Storage.

Locate on a dry level surface. The machine should be stored wherever possible so the rams are not supporting any weight. The drive chains should be lubricated with suitable roller chain lubricant before prolonged periods of storage.

It is recommended that maintenance be carried out at the end of the season, giving sufficient time to obtain spare parts and/or carry out repairs if required.

The seed and fertilizer bins must be completely emptied and cleaned

Leave the metering unit trap doors open.

Fit the cover to the bin.

‘Enviro DD30’ Troubleshooting

Problem	Possible Cause	Action	Refer to Page...
Over Sowing	Jockey wheel under inflated	<i>Check pressure</i>	5
	Are the Jackal meter settings correct?	<i>Check settings</i>	25
	Has the setup/calibration procedure been followed correctly?	<i>Check setup and recalibrate</i>	20
	Gearwheel position incorrect	<i>Check setup for seed type</i>	20
	Crank handle turned too quickly when calibrating	<i>Only 1.5 seconds per revolution</i>	21
Under Sowing	Has the setup/calibration procedure been followed correctly?	<i>Check setup and recalibrate</i>	20
	Gearwheel position incorrect	<i>Check setup for seed type</i>	20
	Are the calibration scales in kg (not lbs)?	<i>Check scales</i>	-
	Sowing at shallow depths. Is there sufficient pressure on the jockey wheel?	<i>Check and adjust spring pressure</i>	-
	Metering unit is clogged	<i>Clean metering unit</i>	-
Cracking noises coming from the metering unit	Very large seed	<i>Remove roll pins from agitator shaft</i>	

'Enviro DD30' Phasing Cylinders

Commisioning Phasing Cylinders

1. General

(a) The cylinders will re-phase in both directions. Each piston is fitted with 2 poppet valves which open at the end of the stroke to allow oil to bypass the piston. The bypass of oil at the end of the stroke allows for initial bleeding of the system and re-phasing in operation.

(b) The valve in the piston is a precision device, **CLEANLINESS IS OF THE UTMOST IMPORTANCE.** Contamination in the oil will accelerate deterioration of the valve seat. Cylinders will creep once the integrity of the seating is lost.

2. Bleeding the System

(a) Initial bleeding after connection to the tractor

Purge all air from the system by fully stroking rams in both directions. Allow the oil to flow through the cylinders with the tractor at an idle for a minimum of 2 minutes at each end of the stroke.

(b) Re-phasing after initial bleeding

After initial bleeding the cylinders will only require occasional re-phasing during operation. This is done by extending the rams for about 30 seconds or until all cylinders have reached the end of their stroke.

3. Fault Finding

1. Cylinders creeping during operation

There are two primary causes of this:

- (i) Air in the hydraulic system
- (ii) By passing of the poppet valve.

(a) Check that there is no air in the system. Raise and lower the machine. All cylinders should move instantaneously, any lag indicates that there is air in the system. Other signs of air in the system are hoses vibrating/squealing or the control handle shuddering. Re-bleed the system if necessary.

(b) If there is no sign of air in the system and the cylinders still creep, raise the machine off the depth stop and measure the movement of each cylinder rod.

(c) If both cylinders move at the same rate it is likely to be the control valve/lock out valve that is leaking.

(d) If the slave continues moving after the master cylinder has hit the depth stop it is likely to be the piston in the master cylinder that is bypassing.

(e) If the slave cylinder extends while the master cylinder retracts it is likely to be the piston in the master cylinder that is bypassing.

(f) If the master cylinder does not move but the slave does it is likely to be the piston in the slave cylinder that is bypassing.

(g) If the piston is bypassing it is likely to be contamination in the phasing valve. The cylinder will have to be dismantled, cleaned and fitted with a new poppet valve.

'Enviro DD30' Phasing Cylinders

Commisioning Phasing Cylinders (continued)

3. Fault Finding (continued)

2. Cylinders moving at different rates

(a) Check that there is no air in the system. Raise and lower the machine; all cylinders should move at the same time, any lag indicates that there is air in the system. Re-bleed the system if necessary.

(b) Ensure that the cylinders have been connected correctly. The cylinders should be connected in series so that the bore sizes go down in 1/4" increments. The Rod end port of the master cylinder (3.5" bore) is connected to the piston end port of the slave cylinder (3.25" bore).

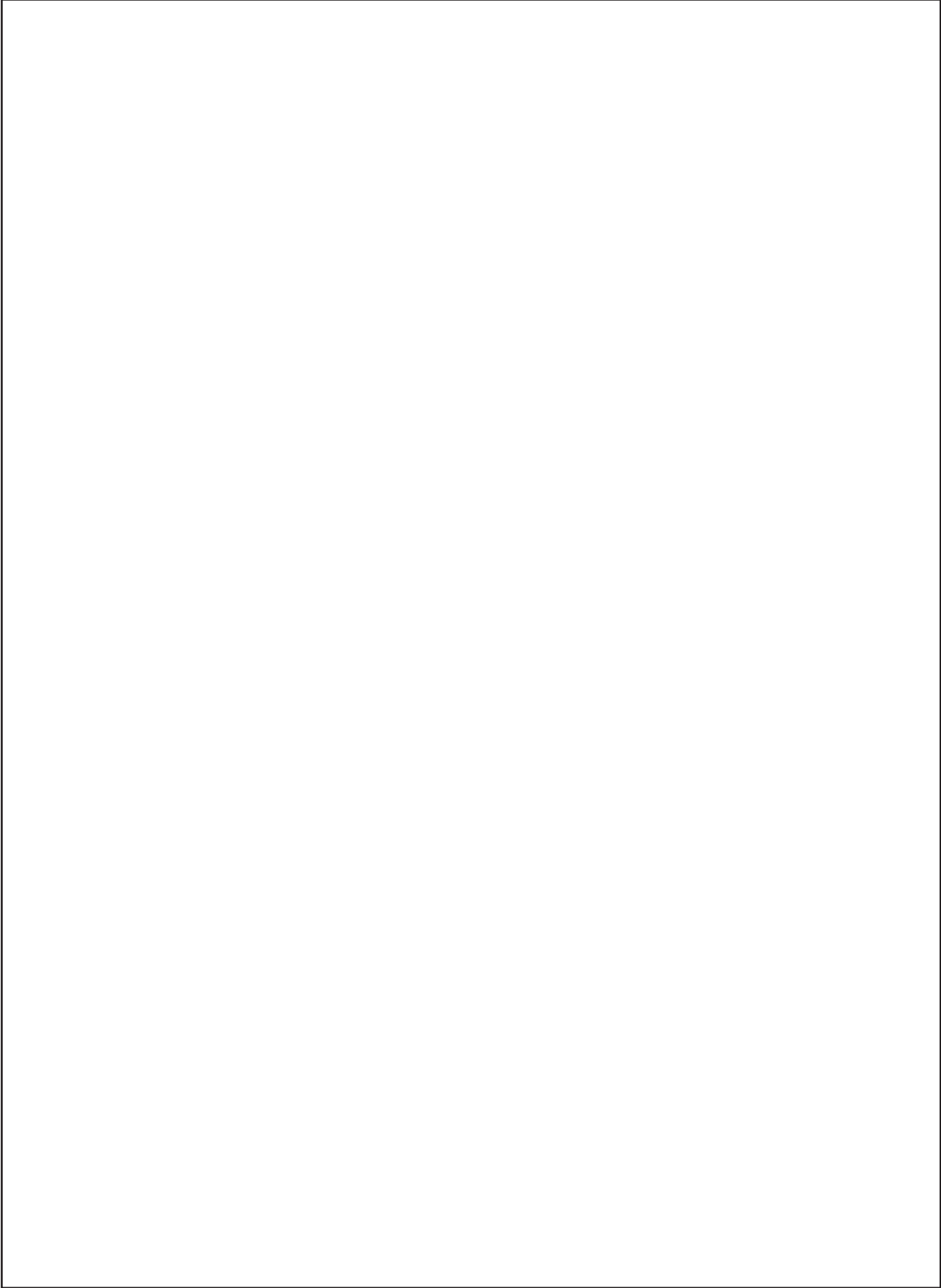

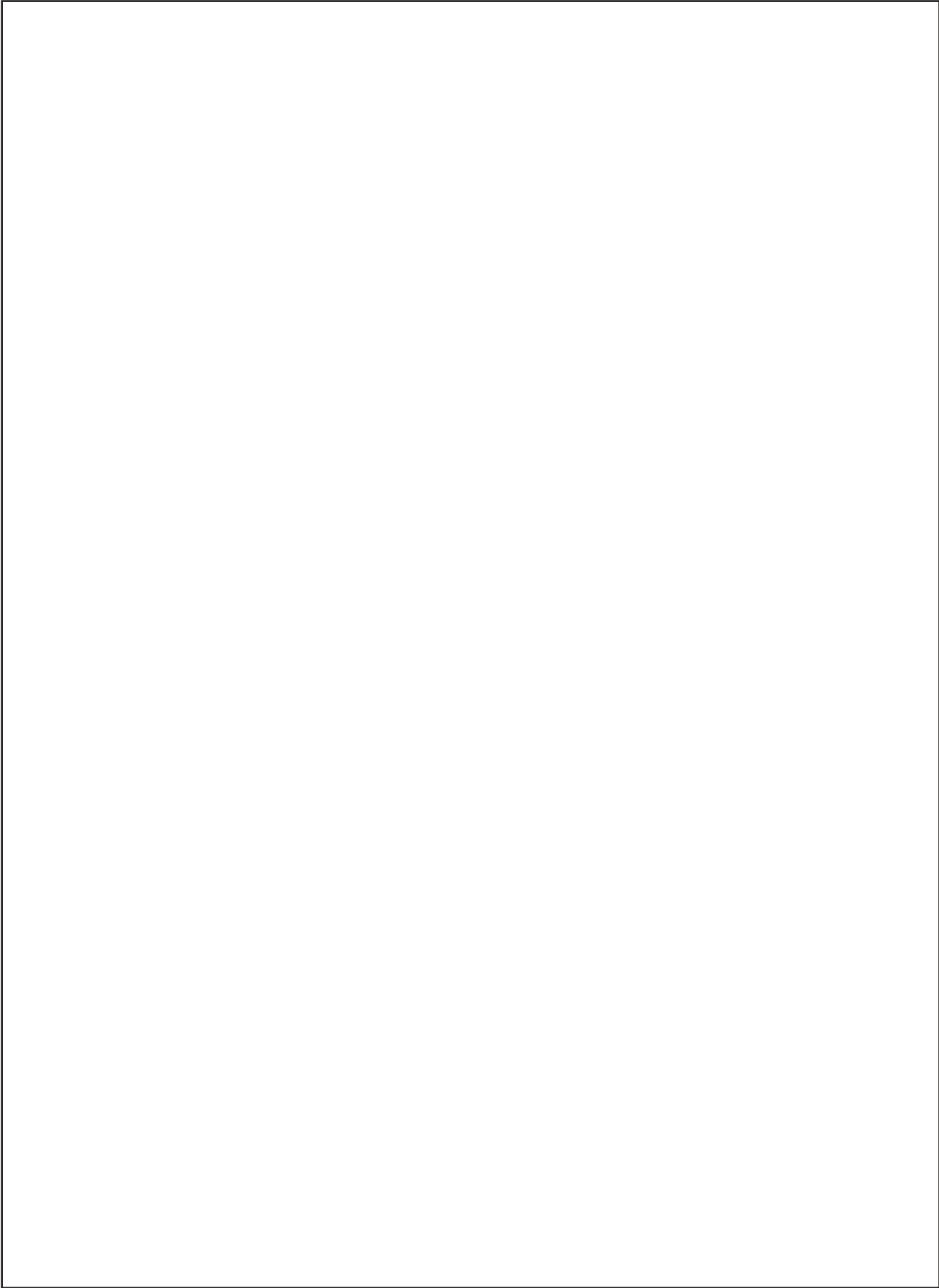

Parts List



'Enviro DD30 Air' Seed Drill

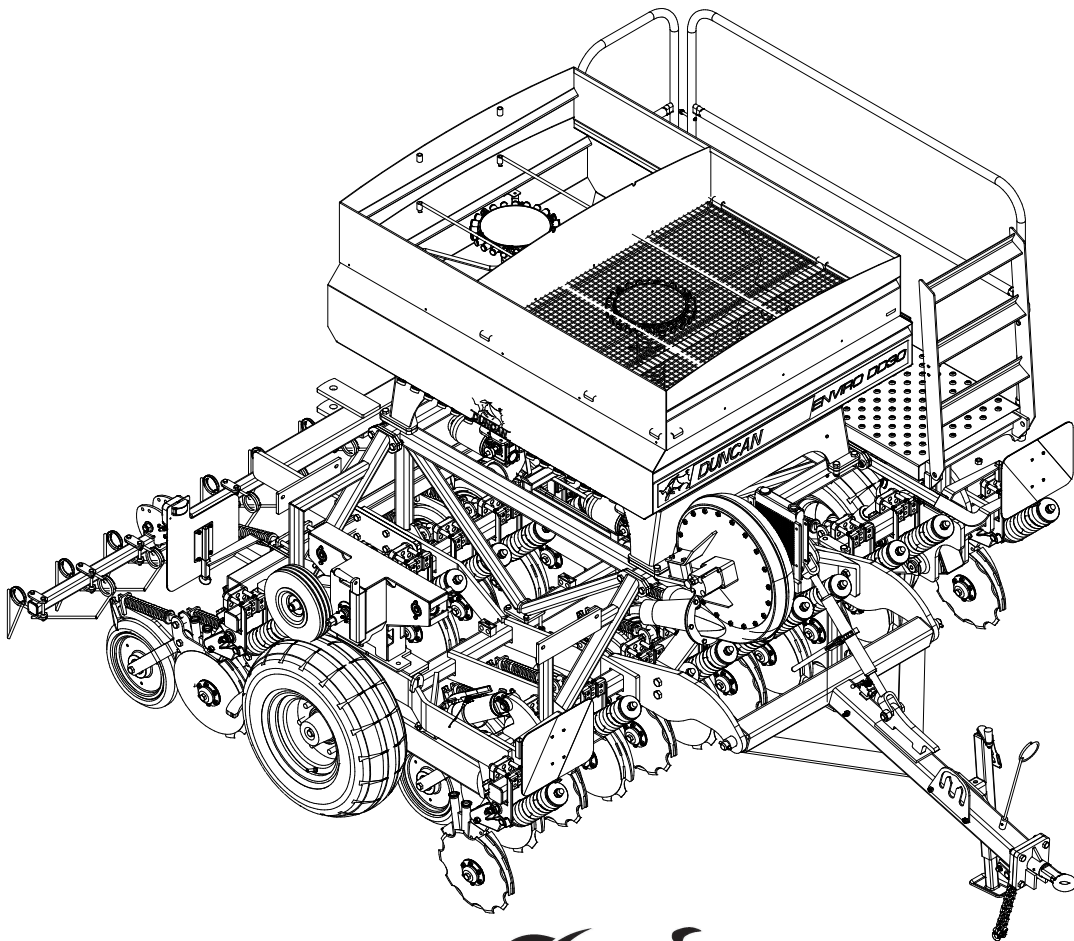

Built to work.

Head Office:
P.O. Box 2018
Hilton Highway, Washdyke
Timaru, New Zealand
Telephone (03) 688 2029
Facsimile (03) 688 2821

Australian Branch:
Building 2 107-117 Boundary
Road
Laverton North, Melbourne,
Victoria 3026 Australia
Telephone (03) 9369-6548
Facsimile (03) 9314-6810

Pt. No. 67394
Issue 0922

'Enviro DD30' Complete Assembly

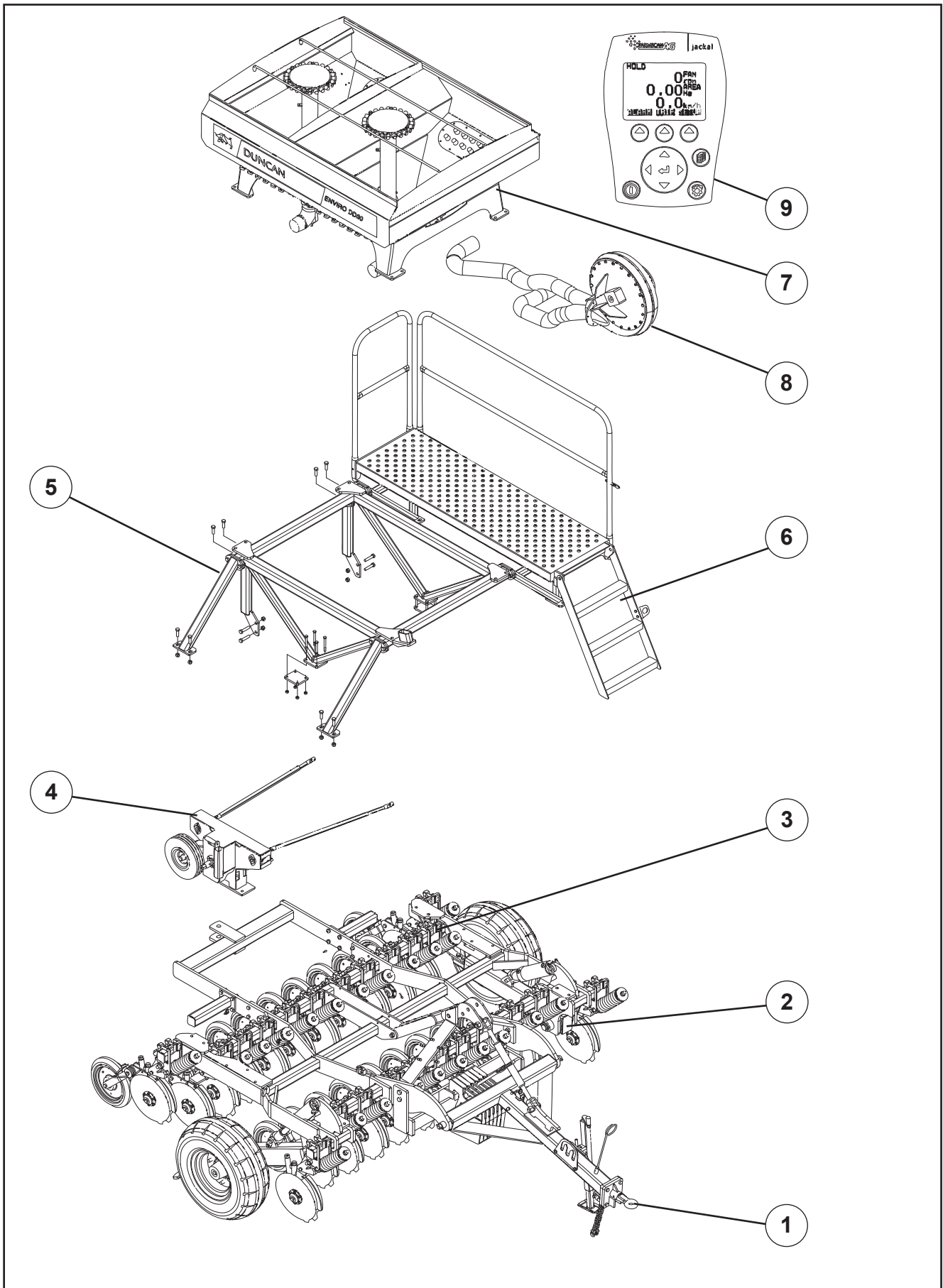

‘Enviro DD30’ Complete Assembly

ITEM	PART No.	DESCRIPTION	QTY
1	Refer Page 42	Main Frame & Drawbar Assembly	-
2	Refer Page 46	Wheel Leg	2
3	Refer Page 50	Disc Assemblies	-
4	Refer Page 62	Seed Metering Drive Pedestal	1
5	Refer Page 68	Box Mounting Frame	1
6	Refer Page 70	Footboard & Ladder	1
7	Refer Page 72	Seed Box & Metering Units	1
8	Refer Page 76	Fan & Air Hoses	1
9	Refer Page 81	Farmscan Jackal	1
10	Refer Page 82	Lighting Kit (Optional)	-
11	Refer Page 84	Rear Tow Hitch & Tine Harrow Mount (Optional)	-
12	Refer Page 86	Tine Harrow (Optional)	-
13	Refer Page 88	Uni-Roller (Optional)	-
14	Refer page 90	Weights (Optional)	-



'Enviro DD30' Mainframe and Drawbar

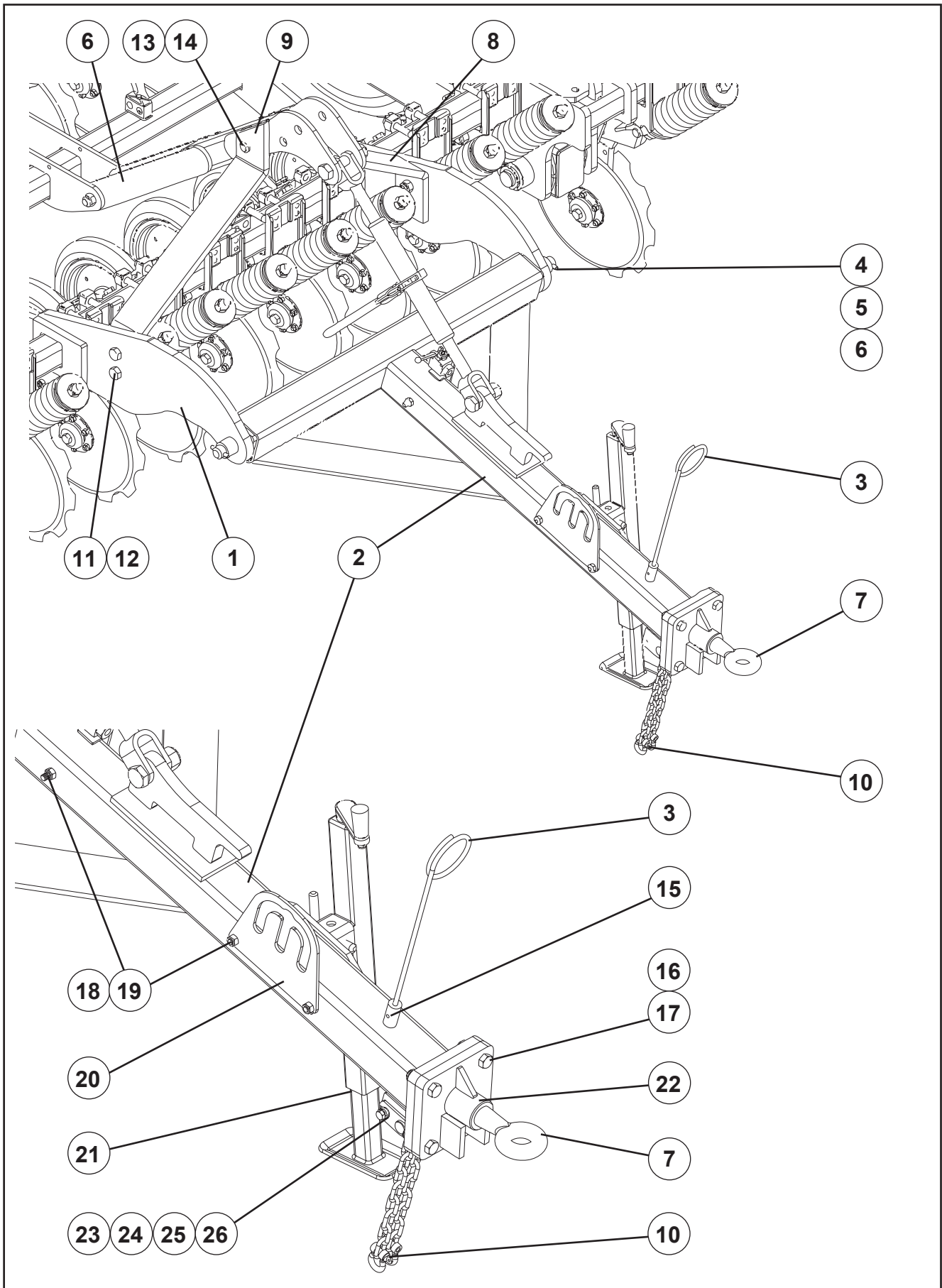

‘Enviro DD30’ Mainframe and Drawbar

ITEM	PART No.	DESCRIPTION	QTY
1	63000	Mainframe 23 Run	1
2	60033	Drawbar Welded Assembly	1
3	4800315	Hose Support	1
4	60094	Drawbar Axle	1
5	45285	Roll Pin	2
6	63115	Centre Hitch Welded Assembly	1
7	60405	Towing Eye Assembly	1
8	26577	LH Support Stay	1
9	26578	RH Support Stay	1
10	43832	Safety Chain Assembly	2
11	45066	M20 x 70 Grade 8.8 Bolt	4
12	45141	M20 Nyloc Nut	6
13	47244	7/8" UNF Bolt x 6.5"	1
14	47548	7/8" UNF Nut	1
15	45181	M8 x 12 S/H Grub Screw	1
16	45042	M16 x 60 Grade 8.8 Bolt	4
17	45140	M16 Nyloc Nut	4
18	45033	M12 x 120 Grade 8.8 Bolt	3
19	45139	M12 Nyloc Nut	3
20	60409P	Hose Rack	1
21	26850k	Stand Kit	1
22	43007	Grease Nipple	1
23	22262	Clevis Pin Tabbed	1
24	45001s	M10 x 20 S/Screw Grade 8.8 ZP	1
25	45152	M10 Light Flat Washer	1
26	45166	M10 Spring Washer	1
27	43660	20 Dia Double Tube Clamp	-

'Enviro DD30' Mainframe and Drawbar

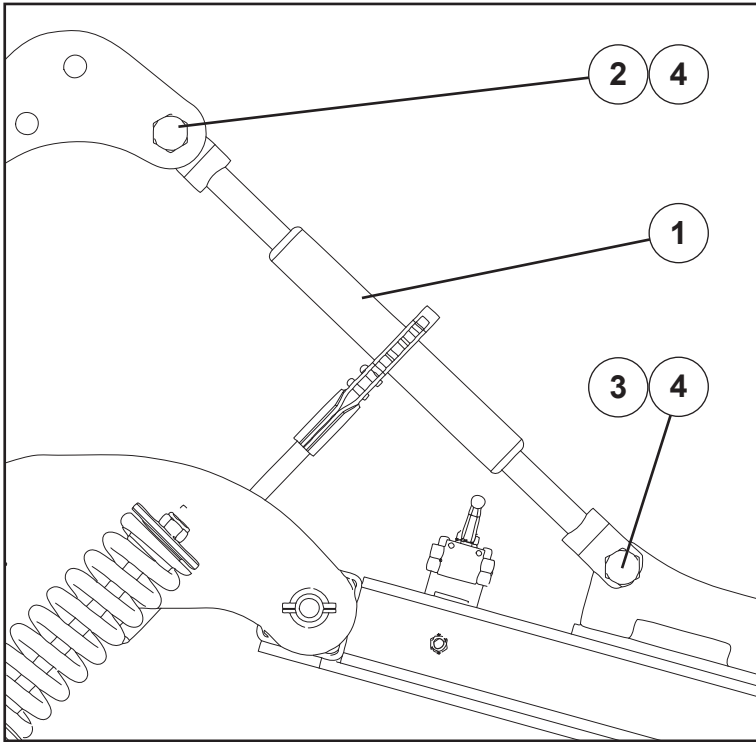

Note: Drawbar hydraulic parts can be purchased as a kit.
The part number is 26720K.

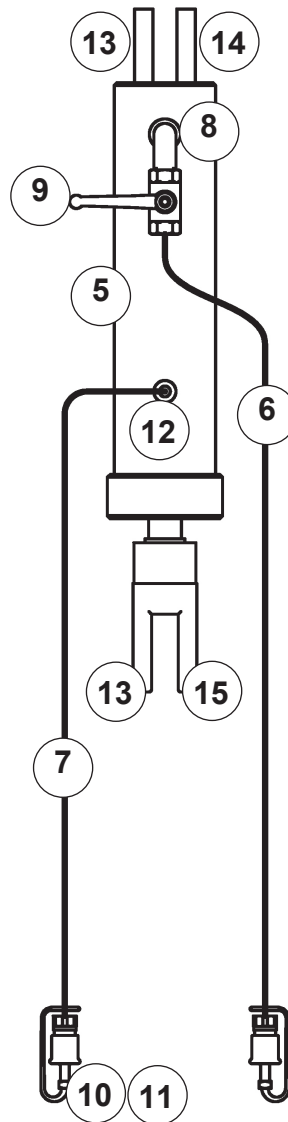

‘Enviro DD30’ Mainframe and Drawbar

ITEM	PART No.	DESCRIPTION	QTY
		Drawbar Turnbuckle Parts	
1	43395	H/D Ratchet Turnbuckle	1
2	47254	Bolt 1" UNF x 5" HT	1
3	47251	Bolt 1" UNF x 3.5" HT	1
4	47552	1" UNF Nyloc Nut	2
		Drawbar Hydraulic Parts	
5	43852	Hydraulic Cylinder	1
6	26723	Hydraulic Hose 2.80m	1
7	26724	Hydraulic Hose 2.50m	1
8	43496	3/4" UNO to 3/8"BSPT Elbow	1
9	43393	3/8" BSP S/S Ball Valve	1
10	43147	1/2" BSP Quick Release Coupling	2
11	43617	Dust Cover	2
12	43280	3/4" UNO to 3/8" BSPM Nipple	1
13	47552	1" UNF Nyloc Nut	2
14	47254	Bolt 1" UNF x 5" HT	1
15	47251	Bolt 1" UNF x 3.5" HT	1
-	48050	Seal Kit for Ram 43852	-

'Enviro DD30' Wheel Leg

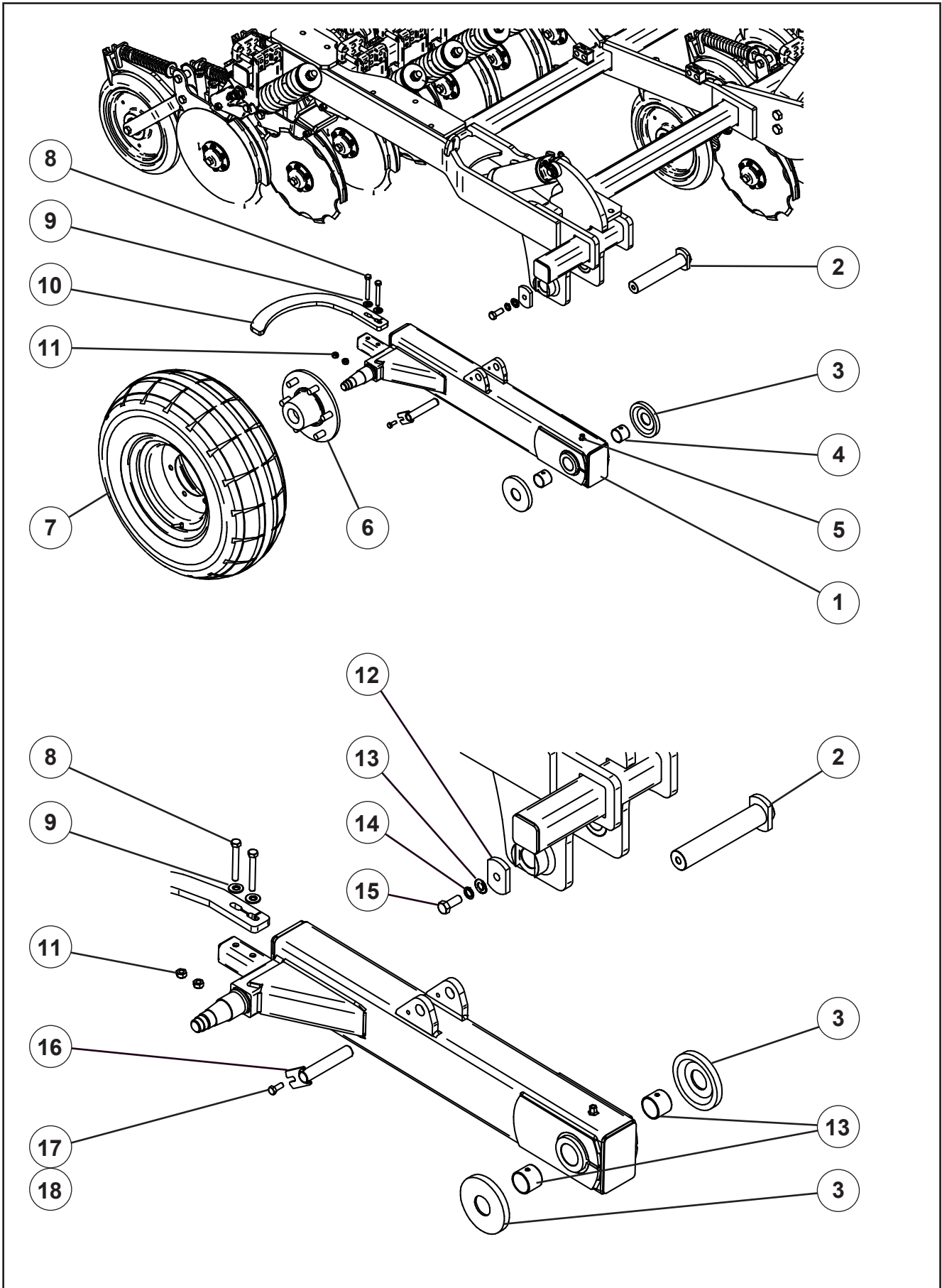

'Enviro DD30' Wheel Leg

ITEM	PART No.	DESCRIPTION	QTY
1	60046	Left Hand Wheel Leg (not shown)	1
1	60062	Right Hand Wheel Leg	1
2	72332	Pin Whl Leg W/Assy	2
3	60065	Spacer	4
4	43426	Glacier Bush Ø45	4
5	43010	90° Grease Nipple	2
6	60245	Mk4 Ren Hub Only ADR-6 Stud	2
6	45648A	Bearing Kit (Mk4 Hub) 60mm	-
6	45648B	Seal Kit(Mk4 Hub60mm)100 X 55	-
6	45648C	Dust Cap (Mk4 Hub)	-
6	45648D	Castle Nut/Pin(Mk4 Axle60mm)	-
6	45648E	Wheel Nut & Washer.Mk4hub 60mm (for 2 hubs)	-
6	45648F	Wheel Stud For Mk4 Hub 60mm (for 2 hubs)	-
7	45638	10.0/75-15,3 Wheel Assy 6 Stud	2
7	45638 RIM	Rim 9X15.3/6 Stud/205 Pcd	-
7	45638 TYRE	Tyre 10/75-15.3 18Ply	-
8	45030	M12 x 90 Gr 8.8 Z/P Bolt	4
9	45159	M12 HD Washer	4
10	60059p	Wheel Scraper	2
11	45139	M12 Nyloc Nut	4
12	72335	Pin Cap Loose Painted	2
13	45154	M16 Light Flat Washer Z/P	2
14	45168	M16 Spring Washer Z/P	2
15	45038s	M16 x 40 Grade 8.8 Z/P S/Screw	2
16	22262	Clevis Pin Assembly	2
17	45418s	M10 x 25 Set Screw	2
18	45166	M10 Spring Washer	2

'Enviro DD30' Wheel Hydraulics

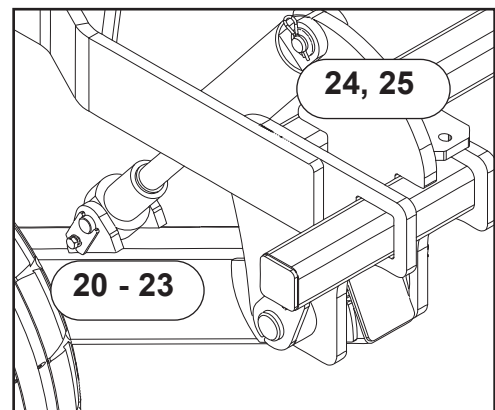
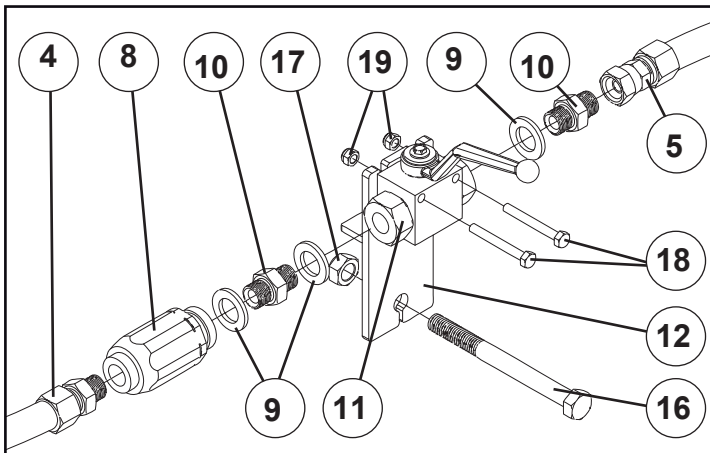
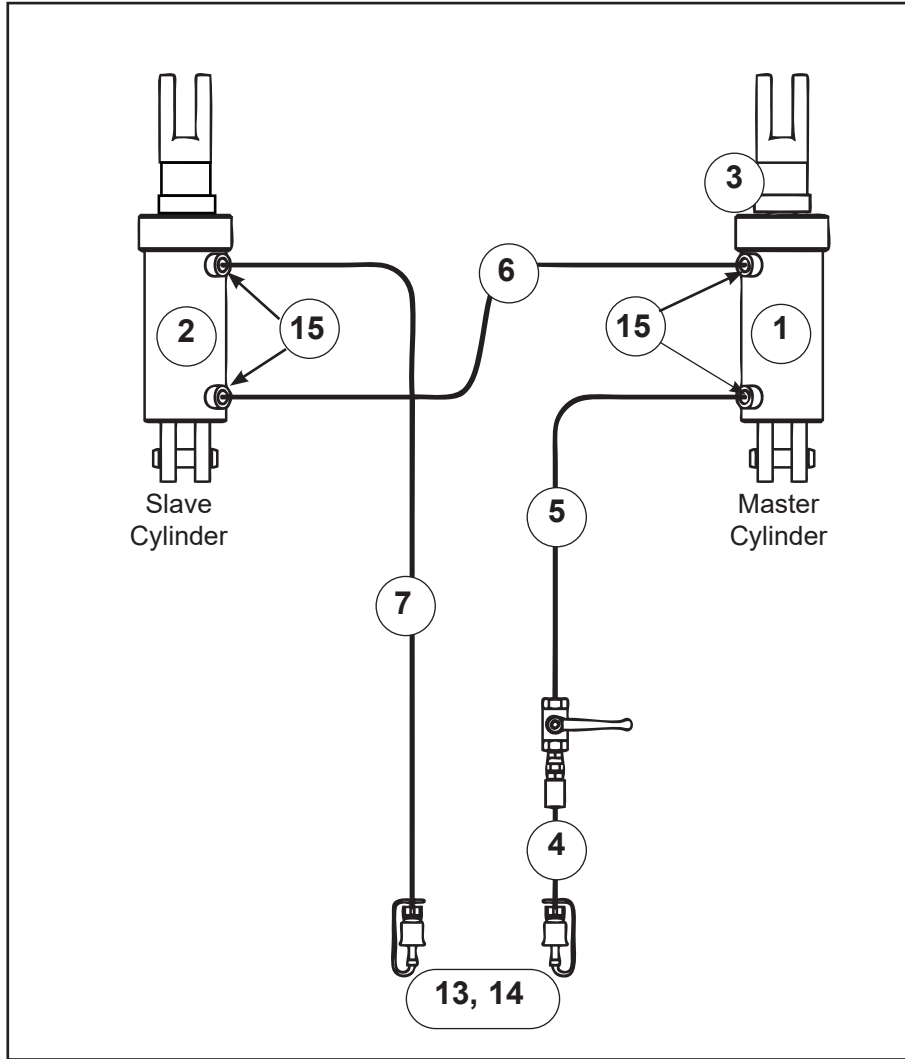

‘Enviro DD30’ Wheel Hydraulics

ITEM	PART No.	DESCRIPTION	QTY
1	26702	3.5" x 6.5" Master Rephasing Cylinder (Includes pin)	1
1	45623	Seal Kit Skslp350-1.25 (suits PTE 26702)	-
1	44192	Seal Kit For 26702 Master (suits Victor 26702)	-
2	26703	3.25" x 6.5" Slave Rephasing Cylinder (Includes pin)	1
2	45622	Seal Kit Skslp325-1.25 (suits PTE 26703)	-
2	44193	Seal Kit For 26703 Rephasing (suits Victor 26703)	-
3	43848	Stroke Limiting Collar 7/8" (where fitted)	1
4	60866	Hydraulic Hose, 2.70m	1
5	60879	Hydraulic Hose, 2.70m	1
6	60864	Hydraulic Hose, 2.85m	1
7	60863	Hydraulic Hose, 5.45m	1
8	43028	3/8" Flow Control	1
9	43391	3/8" Dowty Washer	3
10	43392	3/8" BSPP Male Nipple	2
11	43393	3/8" BSP S/S Ball Valve	1
12	60856	Hydraulic Valve Support Assy	1
13	43147	1/2" BSP Quick Release Coupling	2
14	43617	Dust Cover	2
15	43280	3/4" UNO to 3/8" BSP Nipple	4
16	45033	M12 x 120 Bolt	1
17	45139	M12 Nyloc Nut	1
18	44957	M6 X 50 Bolt	2
19	45136	M6 Nyloc Nut	2
20	22270	Clevis Spacer (spares)	2
21	22262	Clevis Pin Assembly	2
22	45002s	M10 x 25 Set Screw	2
23	45166	M10 Spring Washer	2
24	26558	Clevis Pin (spares)	2
25	45272	R Clip (spares)	2
26	45156	M6 H/D Flat Washer	2
27	43660	20 Dia Double Tube Clamp	-
28	60861k	3.0m Renovator Mk4 Hose Kit	-

'Enviro DD30' Disc Assemblies

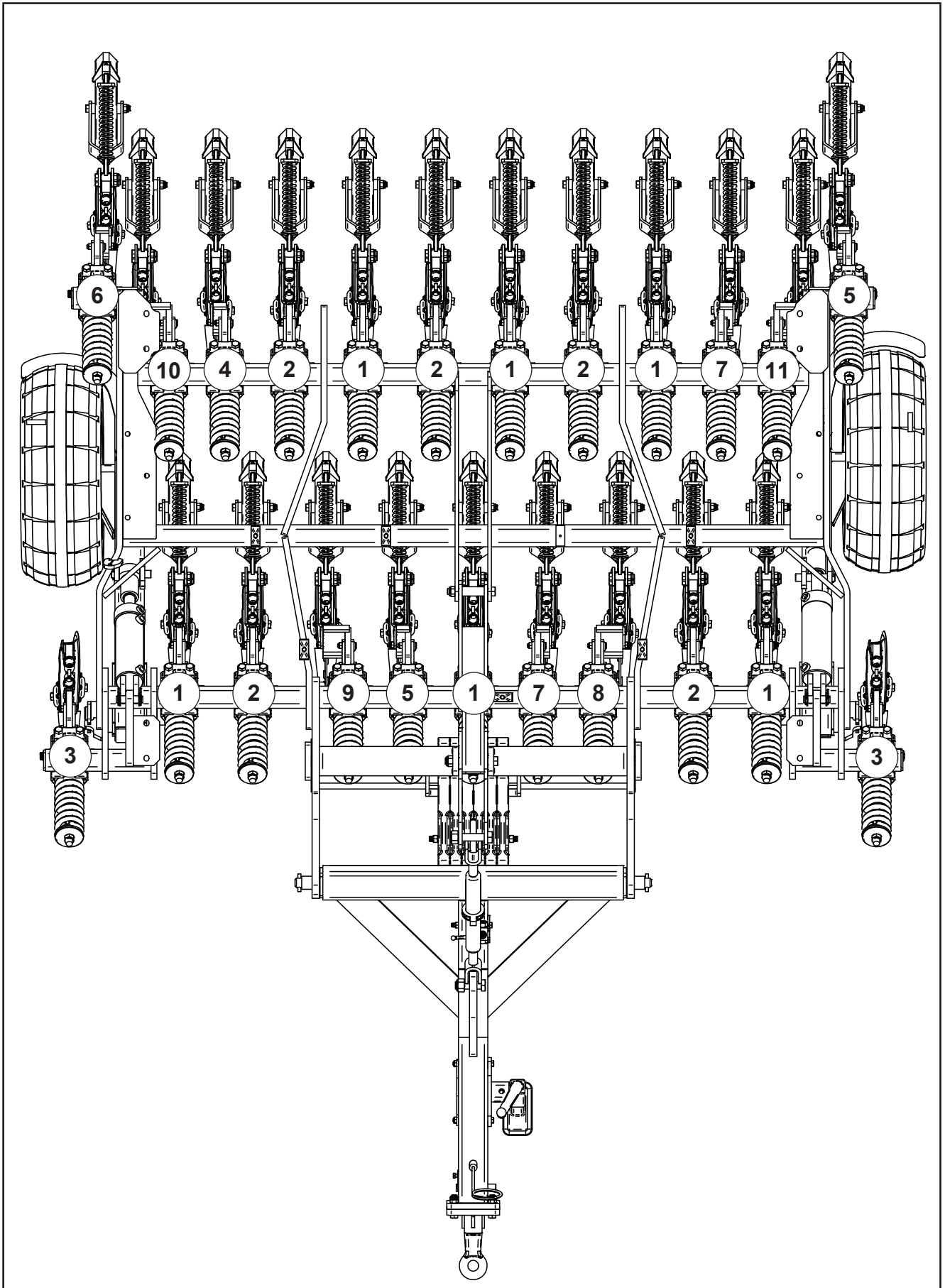

'Enviro DD30' Disc Assemblies

ITEM	DESCRIPTION	QTY
1	Straight Coulter with Press Wheel (LH Leading)	6
2	Straight Coulter with Press Wheel (RH Leading)	5
3	Straight Coulter no Press Wheel (RH Leading)	2
4	40 R Offset Coulter with Press Wheel (LH Leading)	1
5	40 R Offset Coulter with Press Wheel (RH Leading)	2
6	40 L Offset Coulter with Press Wheel (LH Leading)	1
7	40 L Offset Coulter with Press Wheel (RH Leading)	2
8	75 L Offset Coulter with Press Wheel (LH Leading)	1
9	75 R Offset Coulter with Press Wheel (LH Leading)	1
10	90 R Offset Coulter with Press Wheel (RH Leading)	1
11	90 L Offset Coulter with Press Wheel (LH Leading)	1

Disc Identification example

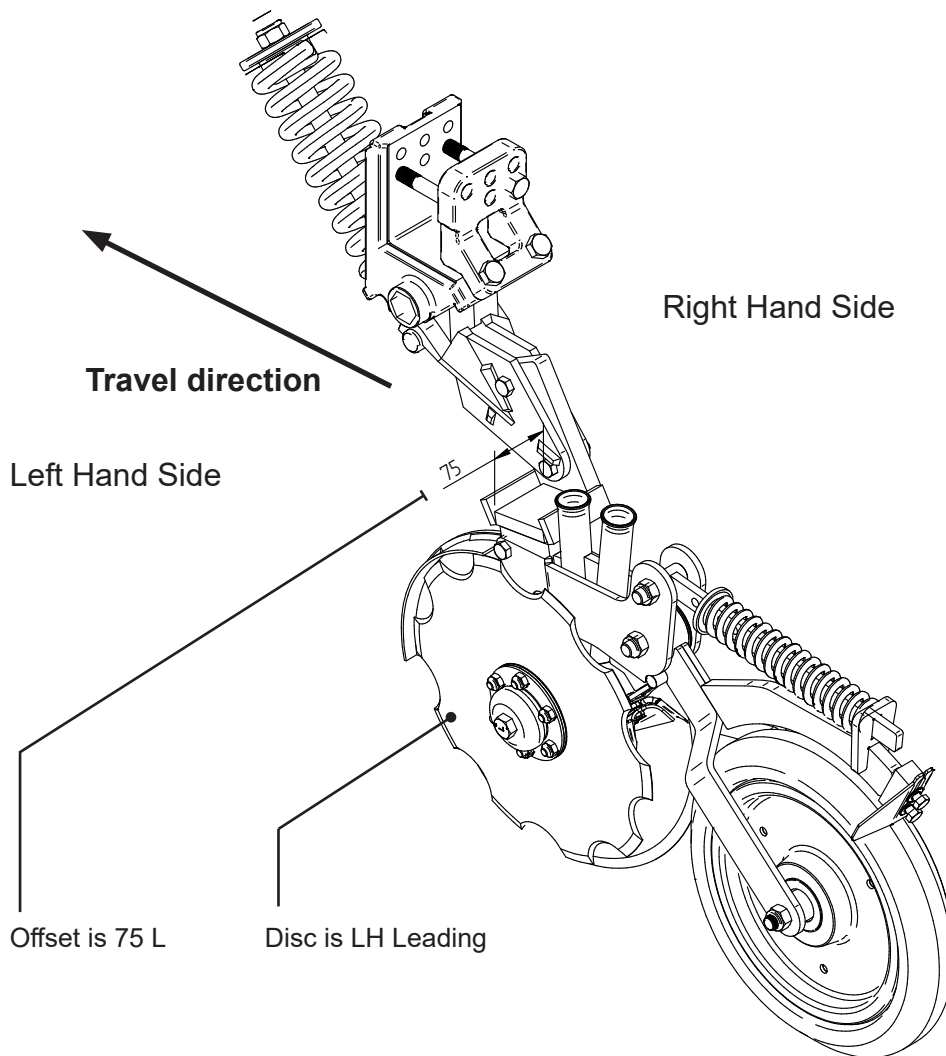

'Enviro DD30' Disc Assemblies

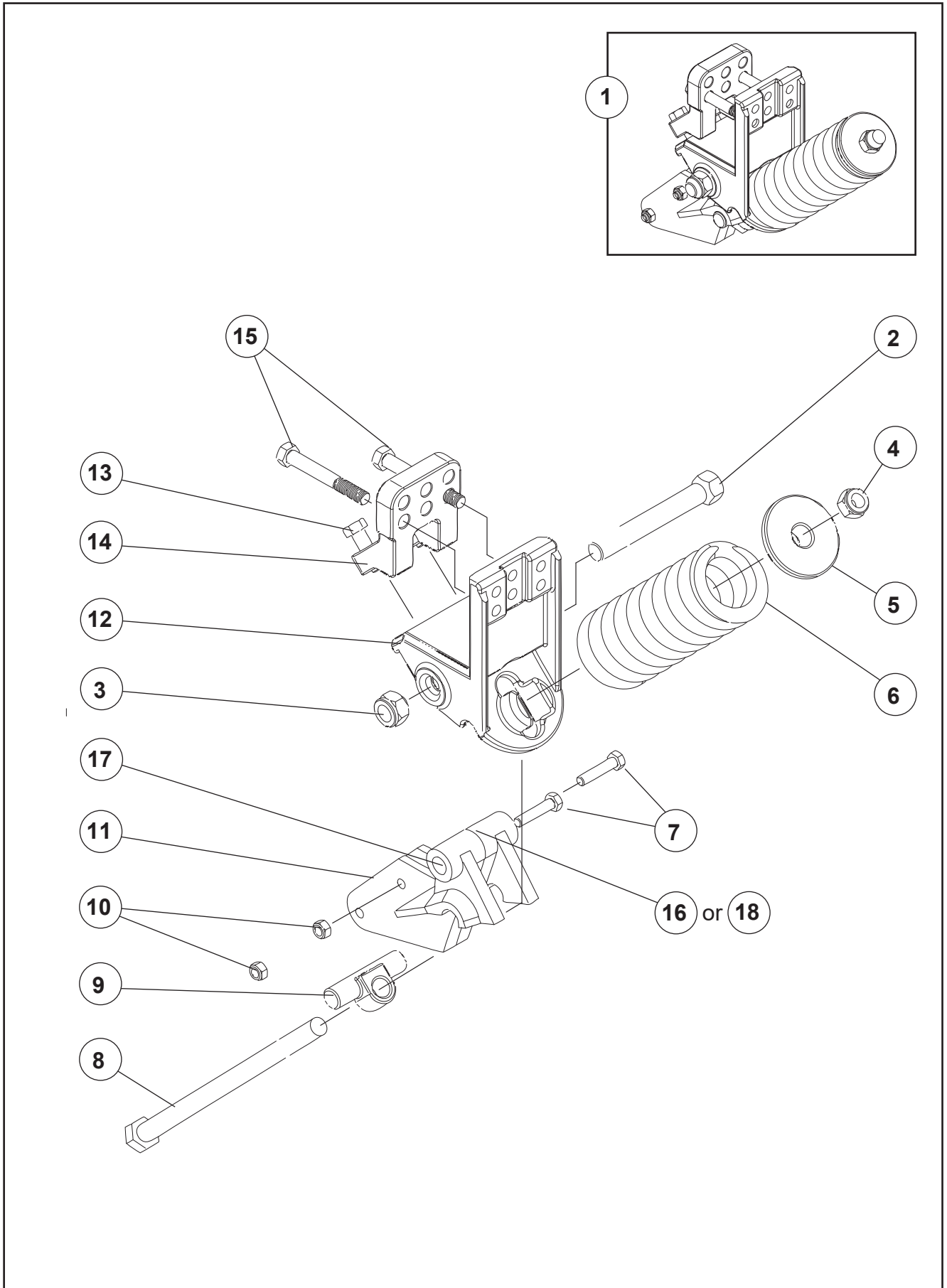

‘Enviro DD30’ Disc Assemblies

ITEM	PART No.	DESCRIPTION	QTY
1	60801k	Duncan Tine Spring Head	-
2	64510	Pivot Bolt (Cone Seat)	1
3	64511	Pivot Nut (Cone Seat)	1
4	45143	M24 Nyloc Nut	1
5	64512	Spring Cap	1
6	64513	Compression Spring	1
7	45095	M14 x 65 Socket Head Capscrew Grade 10.9	2
8	64514	Spring Bolt	1
9	64515	Spring Bar	1
10	45121	M14 Nyloc Nut	2
11	64516	Pivot Arm (20mm Disc Mount)	1
12	64517	Lower Clamp	1
13	45040	M16 x 50 Grade 8.8 Z/P Bolt	2
14	64518	Upper Clamp	1
15	45050	M16 x 120 Grade 8.8 Z/P Bolt	2
16	-	Grease Nipple M8 x 1P	1
17	64536	Pivot Bush	2
18	44173	6X8mm Straight High Pressure (for remote greasing)	1

'Enviro DD30' Disc Assemblies

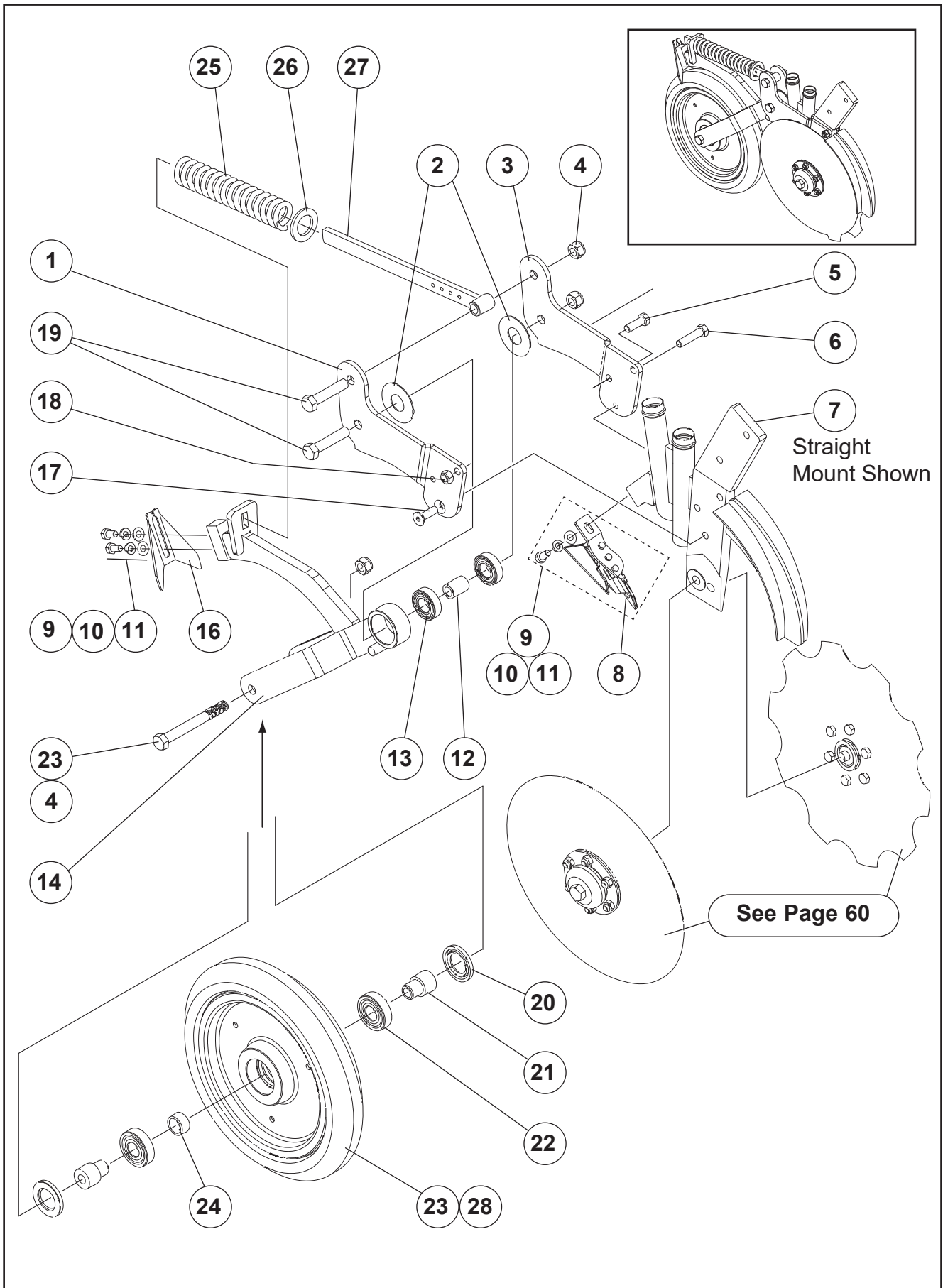

‘Enviro DD30’ Disc Assemblies

ITEM	PART No.	DESCRIPTION	QTY
1	66403	Press Wheel Fixed Plate RH	1
2	43953	Nylon Washer 30 x 70 x 2	2
3	66402	Press Wheel Fixed Plate LH	1
4	45140	M16 Nyloc Nut	3
5	45020	M12 x 35 Grade 8.8 Z/P Bolt	1
6	45023	M12 x 50 Grade 8.8 Z/P Bolt	1
7	Refer Page 56	Disc Mount Sub Assy (Straight shown)	1
8	Refer Page 58	Disc Scraper Assembly	1
9	45152	M10 Light Flat Washer	3
10	45166	M10 Spring Washer Z/P	3
11	45001s	M10 x 20 Grade 8.8 Z/P S/Screw	3
12	63084	Press Wheel Bearing Sleeve	1
13	43939	Bearing 6205	2
14	66407	Press Wheel Arm Welded Assy	1
15	45052	M16 x 140 Grade 8.8 Z/P Bolt	1
16	29267	15"x80mm Wedge P/Wheel Scraper	1
17	45235	M12 x 35 CSK Socket HD Screw	1
18	45139	M12 Nyloc Nut	1
19	45045	M16 x 75 Grade 8.8 Z/P Bolt	2
20	10283	Oil Seal	2
21	61022	Bearing Mount for 6305	2
22	11351	Bearing 6305	2
23	43573	Press Wheel 15"x80 Solid Wedge (Tyre and Rim)	1
24	61021	Bearing Spacer for 6305	1
25	60294	Spring	1
26	63134P	Slide Bar Washer	1
27	66409	Slide Bar W/Assy	1
28	43587	15"X80mm Solid Wedge Tyre (Tyre only)	-

'Enviro DD30' Disc Assemblies

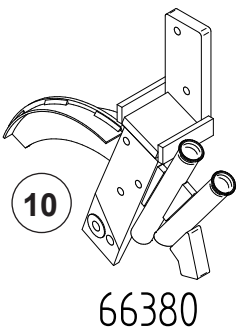
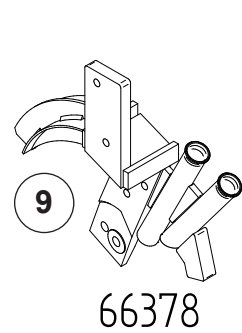
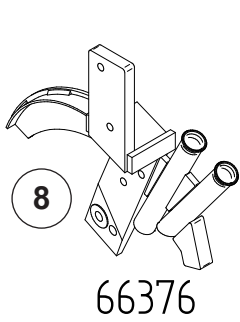
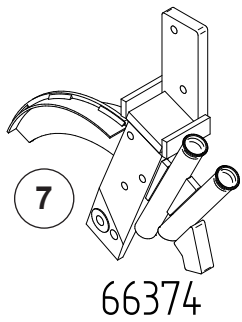
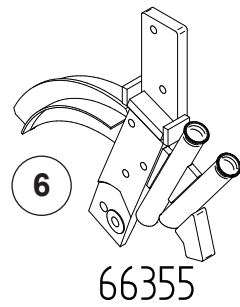
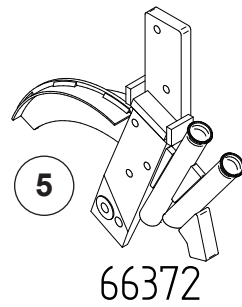
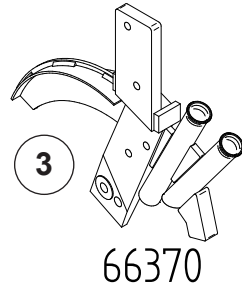
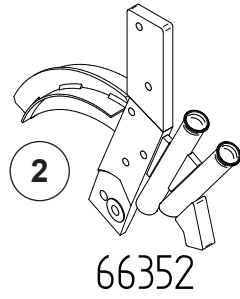
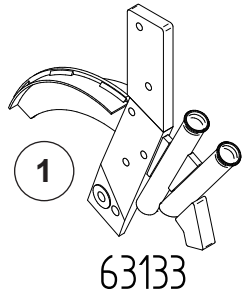

'Enviro DD30' Disc Assemblies

ITEM	PART No.	DESCRIPTION	QTY
1	63133	Straight Coulter (LH Leading)	6
2	66352	Straight Coulter (RH Leading)	7
3	66370	40 R Offset Coulter (LH Leading)	1
4	66357	40 R Offset Coulter (RH Leading)	2
5	66372	40 L Offset Coulter (LH Leading)	1
6	66355	40 L Offset Coulter (RH Leading)	2
7	66374	75 L Offset Coulter (LH Leading)	1
8	66376	75 R Offset Coulter (LH Leading)	1
9	66378	90 R Offset Coulter (RH Leading)	1
10	66380	90 L Offset Coulter (LH Leading)	1

'Enviro DD30' Disc Scrapers

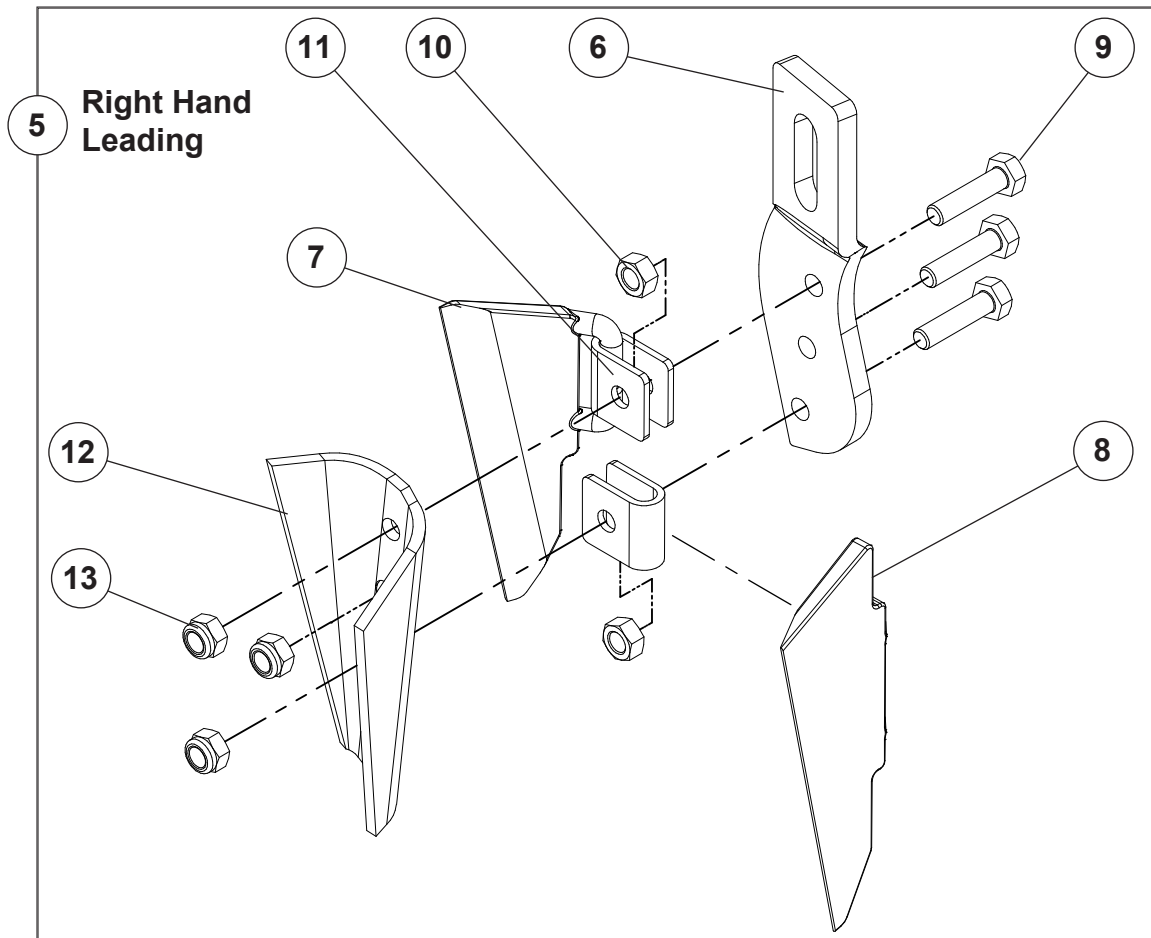
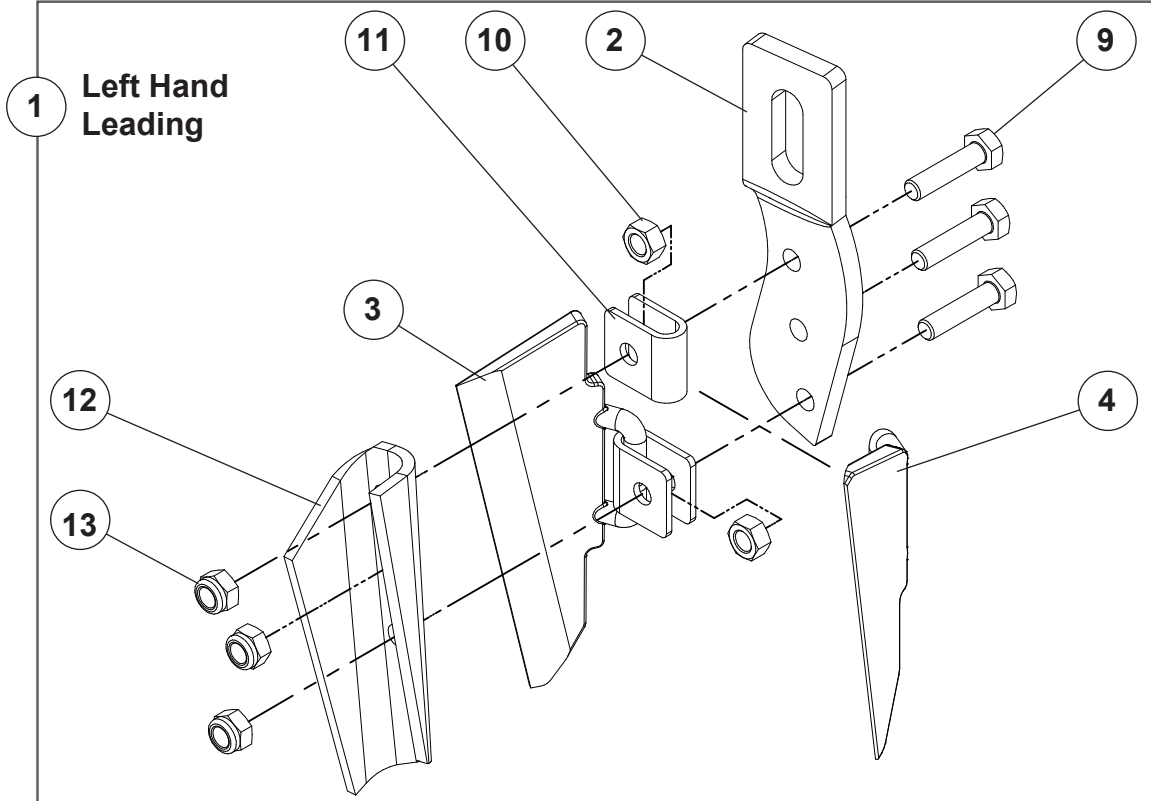

‘Enviro DD30’ Disc Scrapers

ITEM	PART No.	DESCRIPTION	QTY
1	63149	<i>Lhl Dd30 Disc Scraper Assy</i>	-
2	63144	Lhl Scraper Mounting Strap	1
3	63145C	Lh Lhl Scraper Casting	1
4	63146C	Rh Lhl Scraper Casting	1
5	62056	<i>Rhl Dd30 Disc Scraper Assy</i>	-
6	62053	Rhl Scraper Mounting Strap	1
7	62055C	Rhl Scraper Casting (fits to left side)	1
8	62054C	Rhl Scraper Casting (fits to right side)	1
9	44954S	M6 X 25 Grade 8.8 Z/P S/Screw	3 per
10	45122	M6 Grade 8.8 Hex Nut Z/P	2 per
11	63143	Scraper Hinge	2 per
12	63147	Scraper Tensioner	1 per
13	45136	M6 Nylock Nut	3 per

'Enviro DD30' Disc Assemblies

Note: The scalloped disc is always 'leading' but may be fitted to the left or right side; it depends on the disc-mount type. (refer page 56)

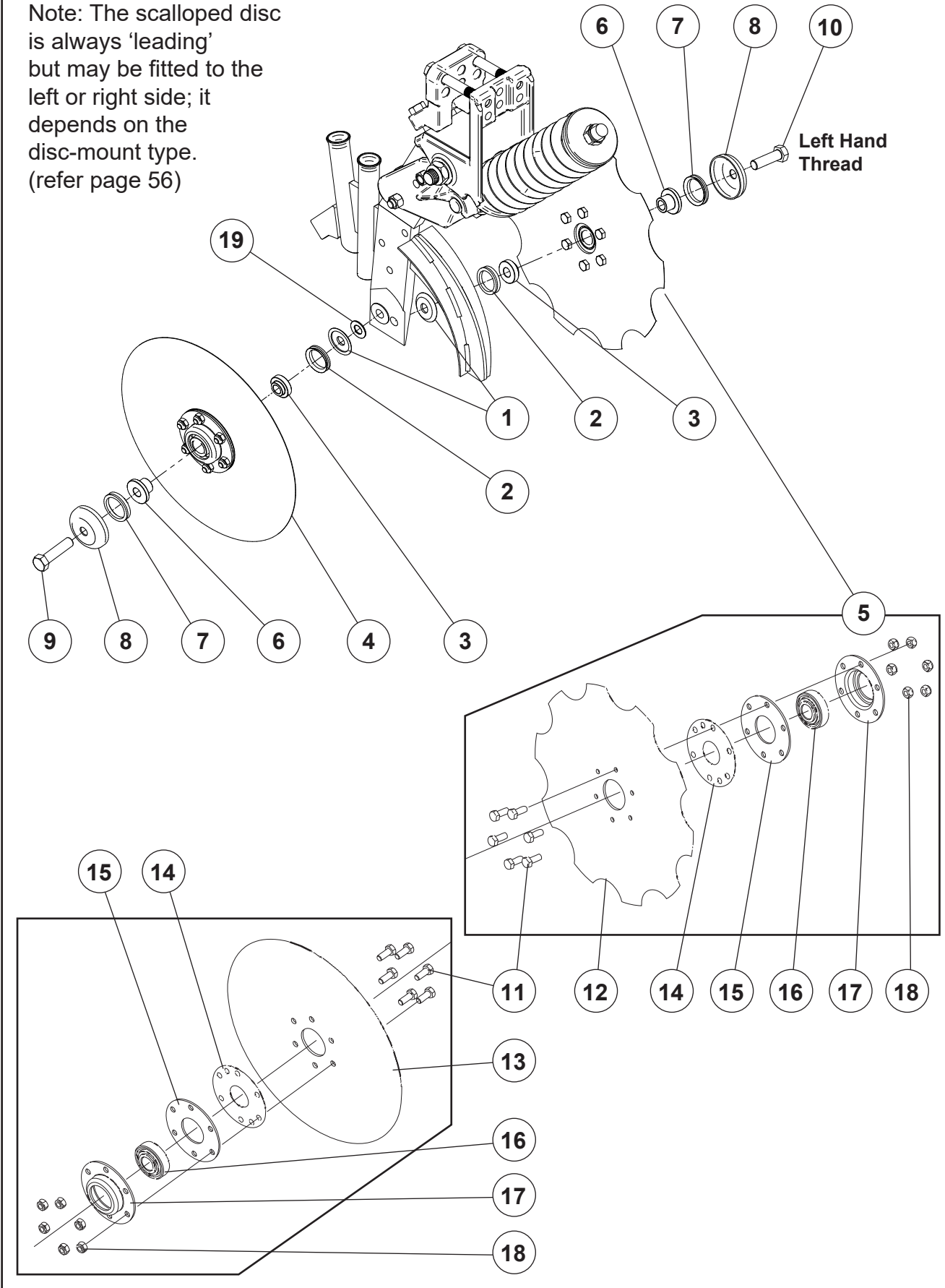

‘Enviro DD30’ Disc Assemblies

ITEM	PART No.	DESCRIPTION	QTY
1	74829	DD Disc Seal Spacer (replaces 45154 & 63102)	2
2	43352	Vee Ring Seal V-40A	2
3	63101	Stepped Spacer	2
4	63071	Plain Disc Sub Assy (includes items 6,7,8,9,10,12,14,15,16,17,18)	1
5	63072	Scalloped Disc Sub-Assy (includes 6,7,8,9,11,12,13,15,16,17,18)	1
6	29241	Bearing and Seal Sleeve	2
7	43891	Vee Ring Seal V-45A	2
8	22077	Dust Cap (16mm Bore)	2
9	45042	M16 x 60 Grade 8.8 Z/P Bolt	1
10	63103*	Disc Retaining Bolt L/H M16x55	1
11	45002s	M10 x 25 Grade 8.8 Z/P Set Screw	12
12	60841	Scalloped Disc 6 Hole One Side	1
13	22002	380 x 4mm Plain Disc 6 Hole	1
14	22081	Seal face Ring	2
15	29244	Bearing Housing Spacer 3mm	2
16	43890	Triple Seal Special Bearing	2
17	29243	Bearing Housing 6 Hole TS	2
18	45138	M10 Nyloc Nut	12
19	45154	M16 Light Flat Washer	1

**Left Hand Thread*

'Enviro DD30' Jockey Drive

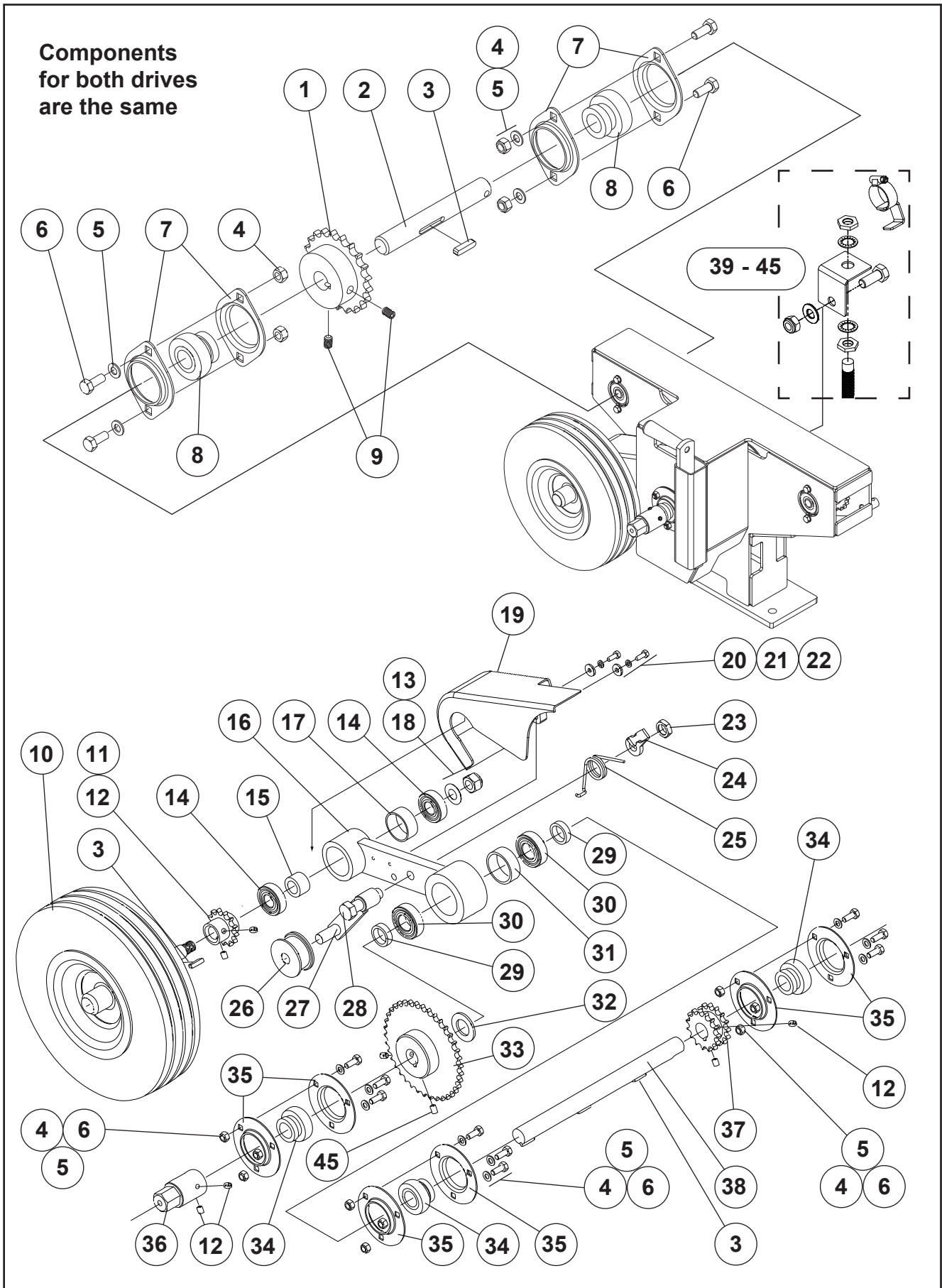

'Enviro DD30' Jockey Drive

ITEM	PART No.	DESCRIPTION	QTY
1	63128	21T Sprocket 1/2"P 20mm Bore	2
2	25758	Box Drive Shaft	2
3	22294	Sprocket Key (6 x 6 x 25)	6
4	45137	M8 Nyloc Nut	17
5	45151	M8 Light Flat Washer Z/P	17
6	44992s	M8 x 20 Grade 8.8 Z/P S/Screw ...	17
7	43387	Bearing Housing PF47 (1 housing = 2 flanges)	4
8	43385	Bearing YET204 20mm	4
9	45181	M8 x 12 Socket/HD Grub Screw (knurled point)	6
10	25744	Jockey Wheel and Axle W/Assy	1
11	25724	13T Sprocket 1/2"x 20mm Bore	1
12	45180	M8 x 10 Socket/HD Grub Screw (knurled point)	6
13	47625	M16 Bellville Washer S/S304	1
14	17127	Bearing 6204	2
15	25739	Jockey Axle Inner Spacer	1
16	25735	Jockey Wheel Arm W/Assembly	1
17	25727	Jockey Axle Outer Spacer	1
18	45140	M16 Nyloc Nut	1
19	25746	Jockey Drive Swing Guard	1
20	45156	M6 H/D Flat Washer Z/P	2
21	45164	M6 Spring Washer	2
22	44951s	M6 x 16 Grade 8.8 Z/P S/Screw	2
23	45119	M16 Grade 8.8 Hex Half-Nut Z/P	1
24	23376	Chain Tensioner Anchor 30 Ext	1
25	22523	Torsion Spring Right Hand	1
26	22535	Chain Tension Roller	1
27	23373	Chain Tensioner Short L/H Assy	1
28	45043	M16 x 65 Grade 8.8 Z/P Bolt	1
29	25725	Jockey Arm Pivot Spacer	2
30	43939	Bearing 6205	2
31	25729	Jockey Arm Pivot Outer Spacer	1
32	45163	M24 H/D Flat Washer Z/P	1
33	25742	38T Sprocket 1/2" x 25mm Bore	1
34	43386	Bearing YET205 25mm	3
35	30359	Bearing Housing PF52 (1 housing = 2 flanges)	3
36	22050	Crank Adapter Assembly	1
37	63127	15T Double Sprocket 1/2"P 25mm	1
38	63126	Drive Pedestal Main Shaft	1
39	72913	Sensor Mounting bracket	1
40	48036	Dia.14-27mm Hose Clip Stainless Steel	1
41	72951	Prox Trigger	1
42	-	Proximity Sensor M12 (AA-487)	1
43	45002s	M10 x 25 Grade 8.8 Z/P S/Screw	1
44	45152	M10 Light Flat Washer Z/P	1
45	45138	M10 Nyloc Nut	1

'Enviro DD30' Chains & Tensioners

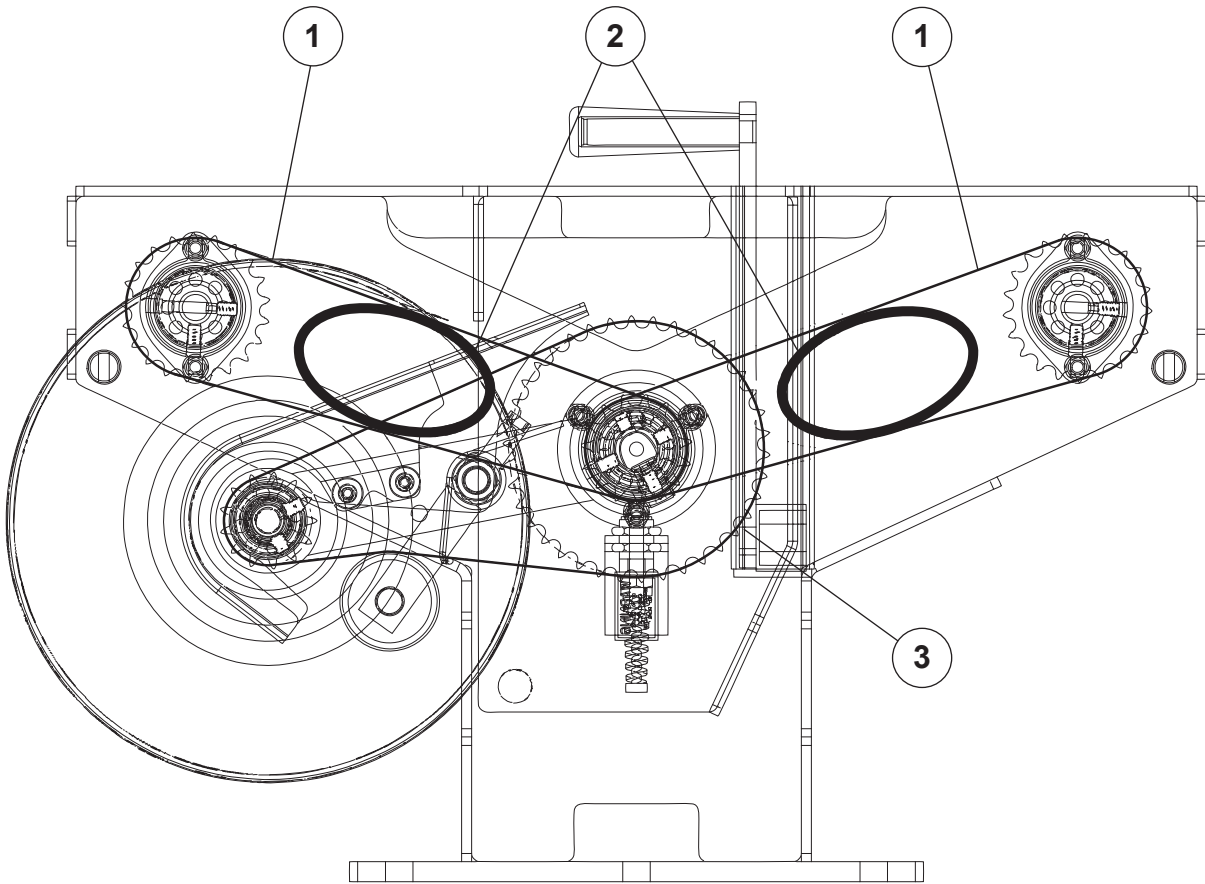

For Jockey Chain Tensioner see
items 23 to 28 on previous page

'Enviro DD30' Chains & Tensioners

ITEM	PART No.	DESCRIPTION	QTY
1	63125	1/2" BS Chain x 63 Links	2
2	44014	Plastic Chain Tensioner	2
3	24103	1/2" BS Chain x 61 Links	1
4	43388	1/2" P Joiner Link	3

'Enviro DD30' Driveshafts (Metering)

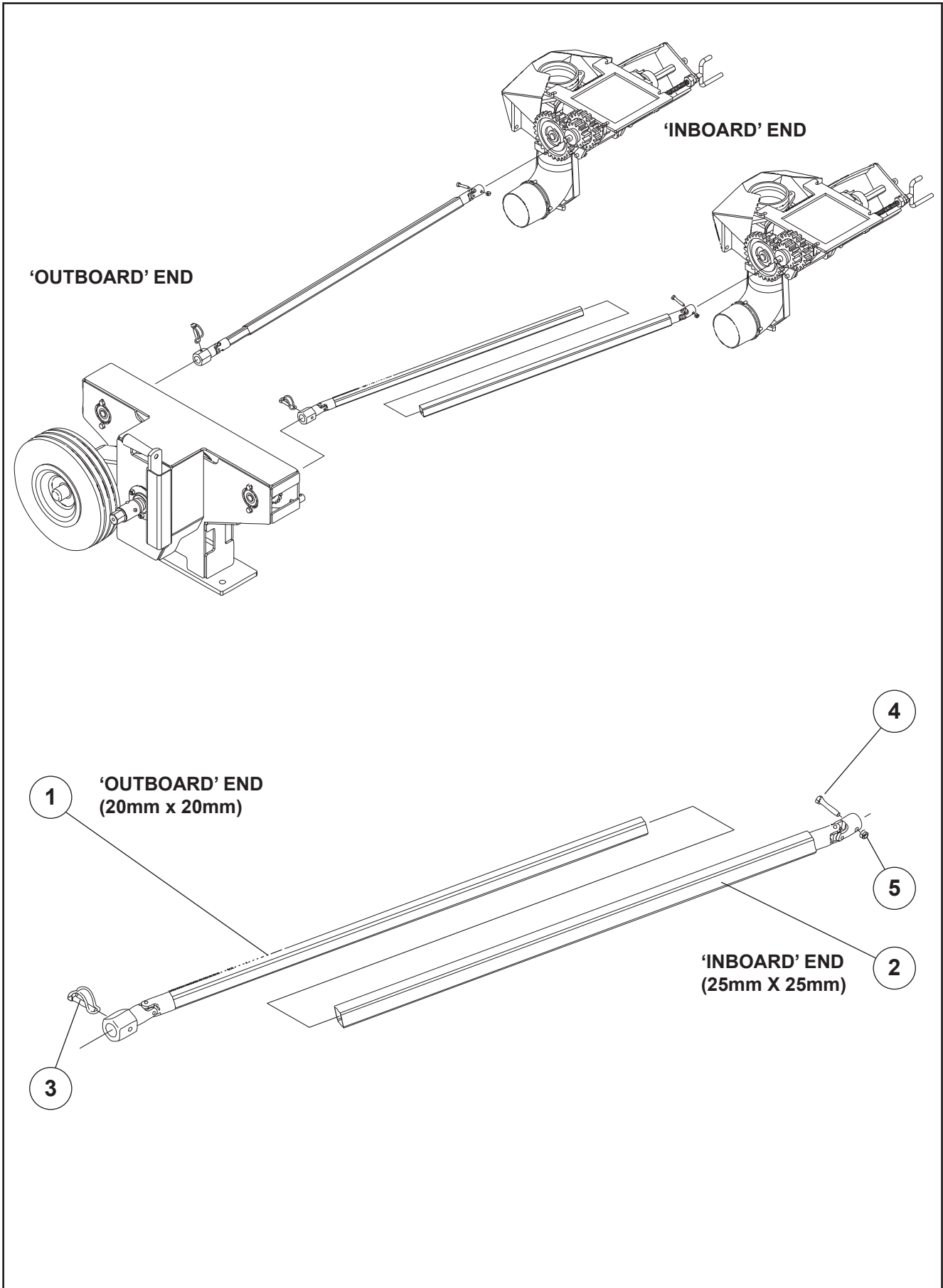

'Enviro DD30' Driveshafts (Metering)

ITEM	PART No.	DESCRIPTION	QTY
1	63230	O/Board Universal Shaft W/Assy	2
2	63231	InBoard Universal Shaft W/Assy	2
3	47615	6 x 40 Pipe Lynch Pin	2
4	44957SS	M6 x 35 304 S/Steel Bolt	2
5	45136SS	M6 Nyloc Nut Grade 316 S/S	2
6	44039	UJ Coupling Rubber Boot (not shown)	4

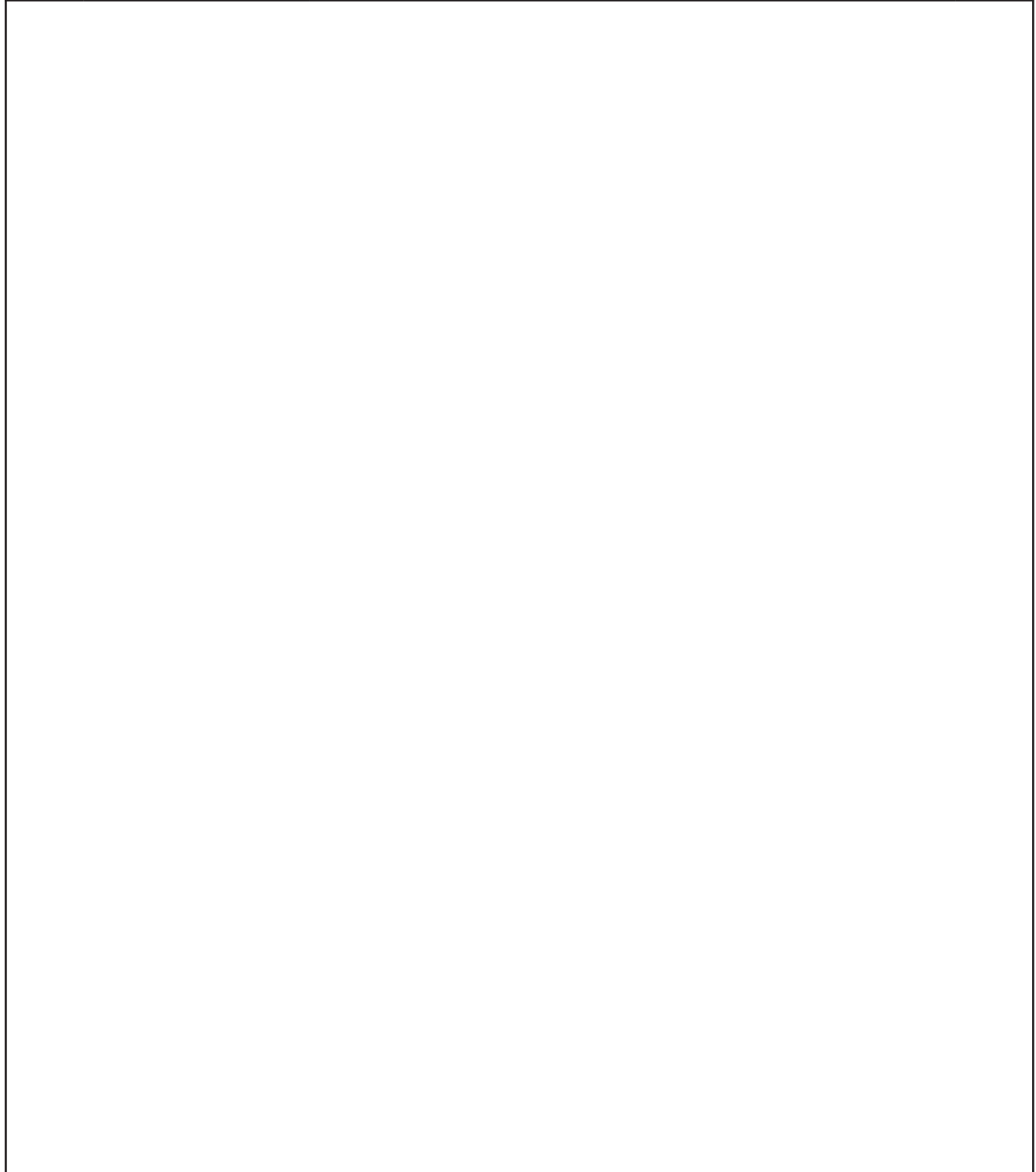

'Enviro DD30' Seedbox Frame

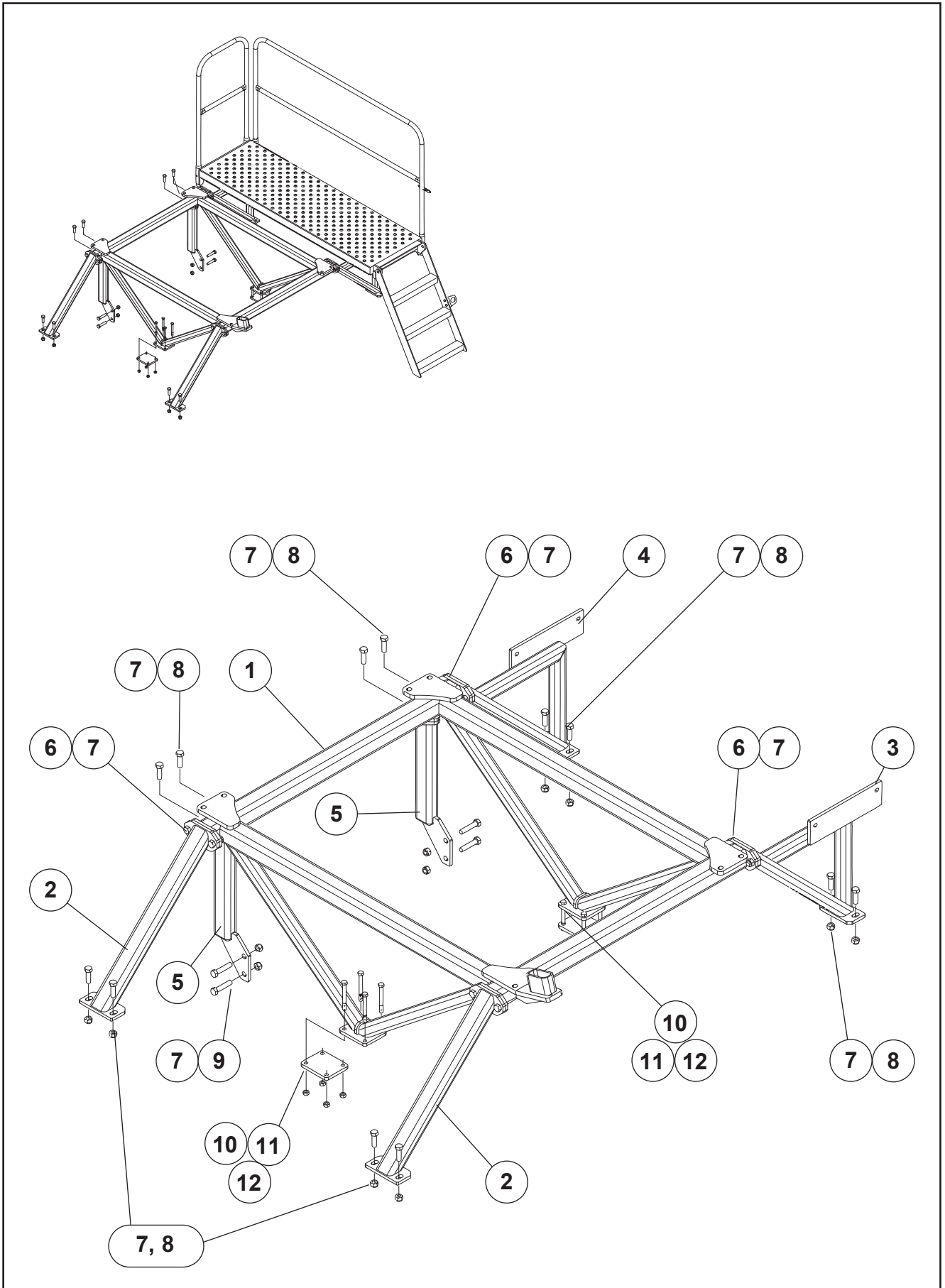

‘Enviro DD30’ Seedbox Frame

ITEM	PART No.	DESCRIPTION	QTY
1	63183	Hopper Mount Frame W/Assy	1
2	63195	Side Support W/Assy	2
3	63205	Frame Brace	1
4	63199	Frame Brace	1
5	63211	Foot Stand W/Assy	2
6	45039	M16 x 45 Grade 8.8 Z/P Bolt	8
7	45140	M16 Nyloc Nut	24
8	45040s	M16 x 50 Grade 8.8 Z/P S/Screw	12
9	45043s	M16 x 65 Grade 8.8 Z/P S/Screw	4
10	45033	M12 x 120 Grade 8.8 Z/P Bolt	8
11	63189	Frame Footplate	2
12	45139	M12 Nyloc Nut	8



'Enviro DD30' Footboard & Ladder

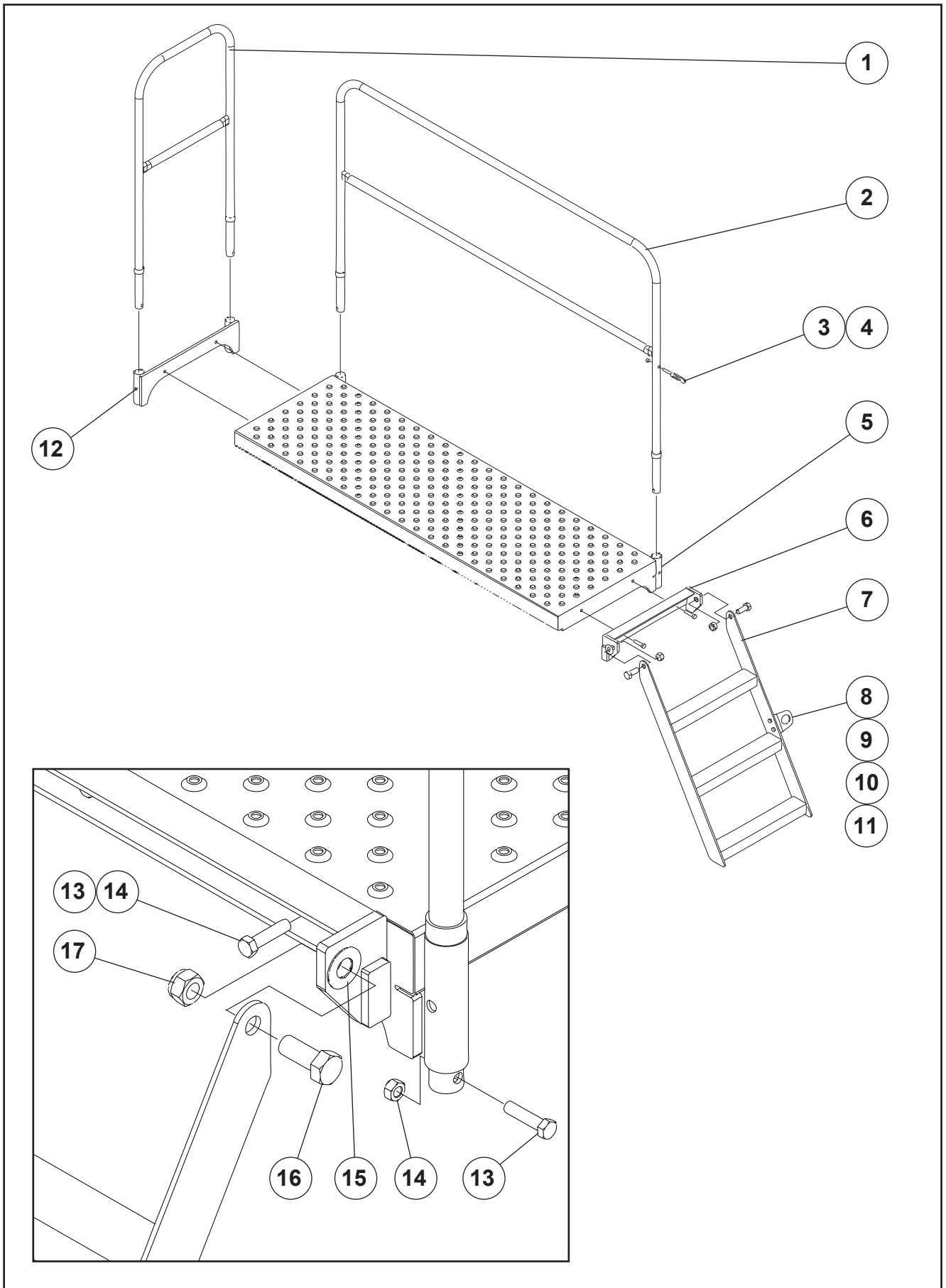

‘Enviro DD30’ Footboard & Ladder

ITEM	PART No.	DESCRIPTION	QTY
1	60163	End Guard Rail W/Assy	1
2	61705	Side Guard Rail W/Assy	1
3	43757	Drop Lock	1
4	45138	M10 Nyloc Nut	1
5	61700	Footboard Assembly	1
6	60170	Footboard Step Bracket W/Assy	1
7	63221	Ladder W/Assy 3 Step	1
8	63220	Ladder Securing Bracket	1
9	45002s	M10 X 25 Grade 8.8 Z/P S/Screw	2
10	45152	M10 Light Flat Washer Z/P	2
11	45138	M10 Nylock Nut	2
12	64122	Guard Rail Multi-Purpose Frame	1
13	45023	M12 x 50 Grade 8.8 Z/P Bolt	8
14	45139	M12 Nyloc Nut	8
15	45155	M20 Light Flat Washer Z/P	2
16	45062	M20 x 50 Grade 8.8 Z/P Bolt	2
17	45141	M20 Nyloc Nut	2

'Enviro DD30' Seed/Fert Box

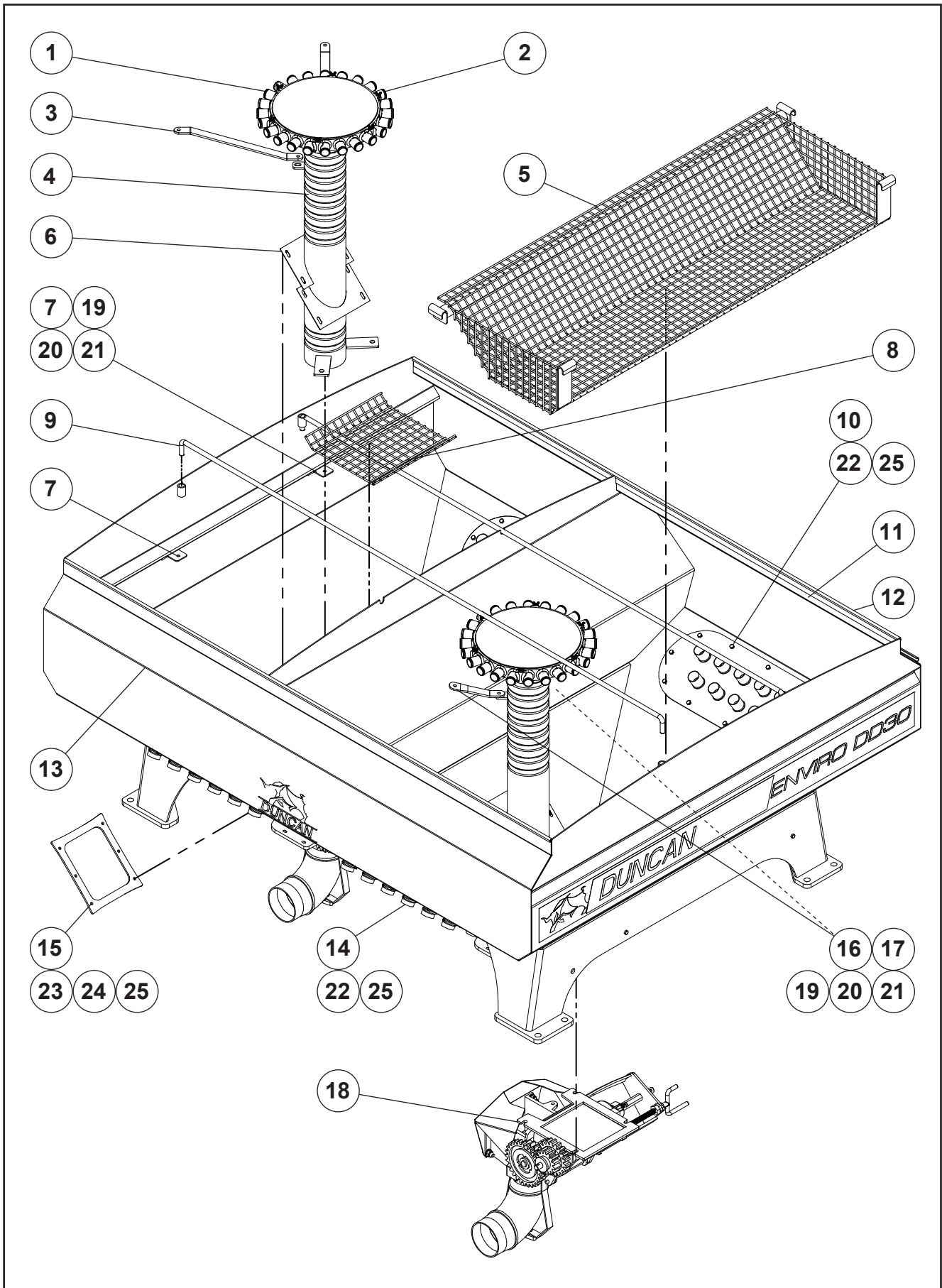

‘Enviro DD30’ Seed/Fert Box

ITEM	PART No.	DESCRIPTION	QTY
1	44064	Air Distributor Head 24 Outlet	2
2	44059	Blanking Plug Seed Distr Head (1 per head)	2
3	72787	Radial Brace Tube Top Support	2
4	44071	Tube	2
5	64427	Mesh Frame W/Assy	1
6	63166P	Outlet Half Moon Flange Profile	4
7	72786	Radial Wall Bracket	2
8	63167	Mesh Grid Filter Hopper Bottom	1
9	63182	Hopper Cover Support Rod	2
10	63168	11 Hole Tube Inset Panel W/Assy (1 per compartment)	2
11	63150	MS Hopper W/Assy	1
12	43373	Edgetrim Black (per metre)	-
13	63173	Cover Holding Extrusion	-
14	63170	12 Hole Tube Inset Panel W/Assy (1 per compartment)	2
15	63260P	Hopper Gasket Support Profile	2
16	72789	Rh Radial Brace Short	1
17	72788	Lh Radial Brace Short	1
18	Refer Page 74	Metering Unit	2
19	45412sss	M8 X 25 S/Screw St. Stl.	-
20	45151ss	M8 Light Flat Washer 304 S/S	-
21	45137ss	M8 Nylock Nut Grade 304 S/S	-
22	44951sss	M6 x 16 316 S/S S/Screw	-
23	45402sss	M6 X 20 Grade 304 Ss S/Screw	-
24	45150SS	M6 Light Flat Washer 304 S/S	-
25	45136SS	M6 Nylock Nut Grade 304 S/S	-
26	43430	Plastic lashing Hooks (not shown)	11
27	63174	Ripstop Hopper Cover (not shown)	1
28	63251	Air Delivery Hose Long (not shown)	1
29	63252	Air Delivery Hose Short (not shown)	1
30	44167	32mm Nylaflow Air Seeder Hose	40mtr
31	43691	38mm Nylaflow Air Seeder Hose	71mtr

'Enviro DD30' Metering Unit

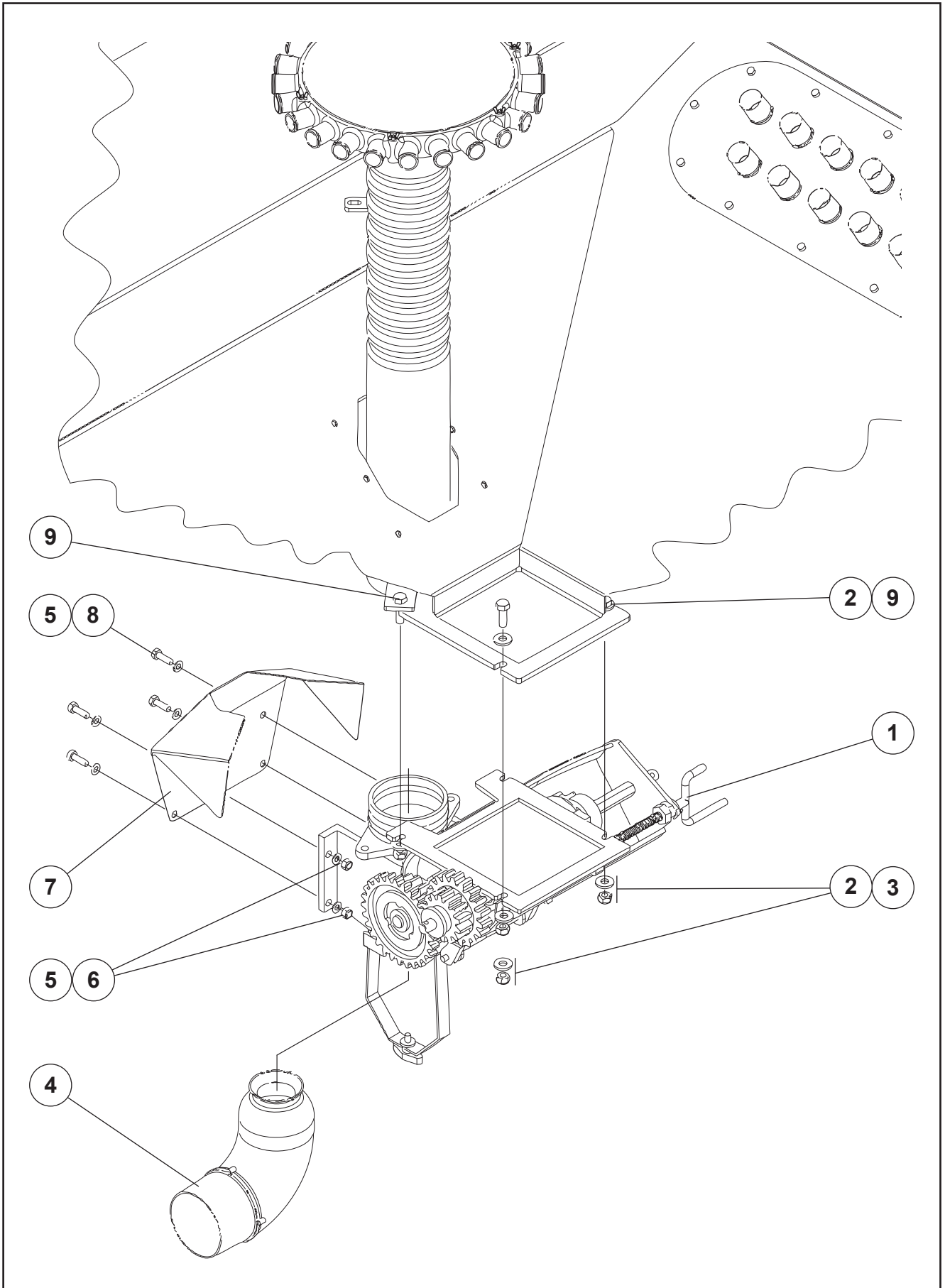

'Enviro DD30' Metering Unit

ITEM	PART No.	DESCRIPTION	QTY
1	44063	Metering Device	1
2	45152	M10 Light Flat Washer Z/P	6
3	45138	M10 Nyloc Nut	4
4	44068	Elbow	1
5	45151	M8 Light Flat Washer Z/P	8
6	45137	M8 Nyloc Nut	4
7	63259	Cover	1
8	44993s	M8 x 25 Grade 8.8 Z/P S/Screw	4
9	45004	M10 x 35 Grade 8.8 Z/P Bolt	4
10	44101	Bracket (spare)	-
11	44099	Toggle (spare)	-

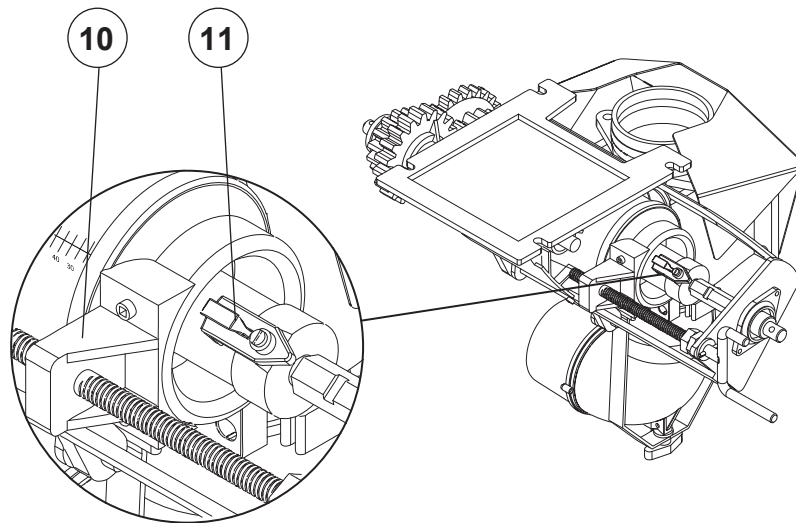

'Enviro DD30' Fan & Air Hoses

ITEM	PART No.	DESCRIPTION	QTY
1	44017	Blower 15 Series	1
2	44992s	M8 x 20 Grade 8.8 Z/P S/Screw	6
3	44018	Flanged Blower Manifold Splitter	1
4	45137	M8 Nyloc Nut	6
5	45139	M12 Nyloc Nut	2
6	45032	M12 x 110 Grade 8.8 Z/P Bolt	2
7	63237	Fan Support Block	1
8	44144	Bearing Block Opspr2 (between motor and fan)	1
9	44019	Galtech 11cc Hydraulic Motor	1
10	63251	Air Delivery Hose Long (not shown)	1
11	63252	Air Delivery Hose Short (not shown)	1

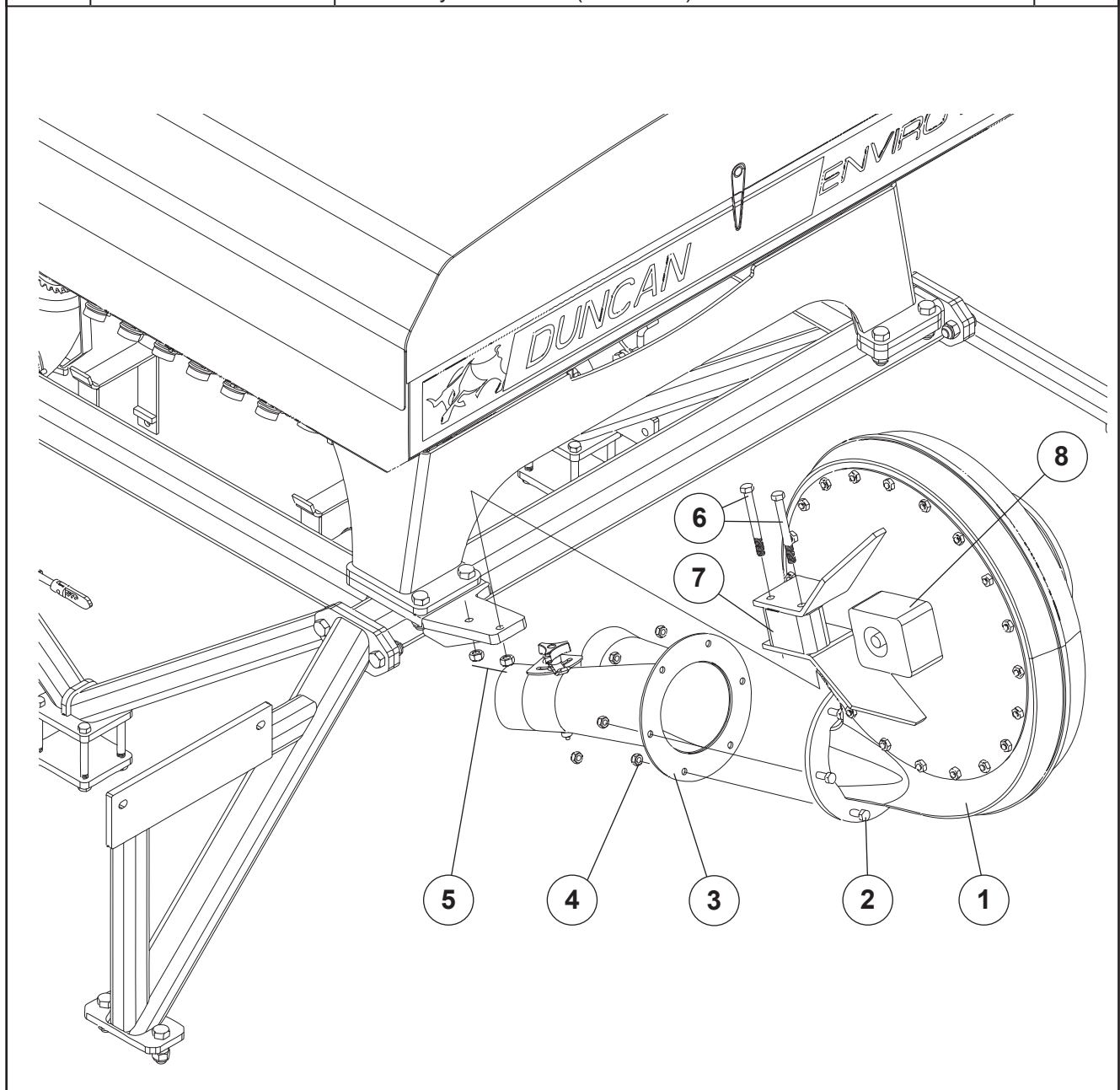

'Enviro DD30' Fan Hydraulics

ITEM	PART No.	DESCRIPTION	QTY
-	44060k	FAN MOTOR HOSE KIT contains items 1 to 13:-	
1	44072	Hydraulic Hose (4.0m)	1
2	44073	Hydraulic Hose (3.38m)	1
3	44074	Hydraulic Hose (4.15m)	1
4	44075	7/8" UN'O x 1/2" BSPPM Nipple	1
5	48094	7/8" UN'O'x 3/4" BSP Nipple	1
6	44078	9/16"JICF x 1/4"BSPM 90°	1
7	44080	3/4" BSP Female Q.R. Coupling	1
8	44081	3/4" BSP Male Q.R. Coupling	1
9	43147	1/2" BSP Male Q.R Coupling	1
10	43617	1/2" Female Dust Cover	1
11	44128	3/4" Male Dust Cover	1
12	43148	1/2"BSP Female Q.R.Coupling	1
13	43618	1/2" Male Probe Dust Cover	1
14	44019	Galtech 11cc Hydraulic Motor (Spare parts listed below)	1
15	44144	Bearing Block Opspr2 (between motor and fan)	1
16	44529	Splined Coupling (Blowr Motor)	1
17	44149	Shaft Seal 18 X 30 X 7 - 2 Sp	1
18	44145	Hyd Motor Seal Kit For 44016K	1
19	44351	Flow/Chk Valve For Blowr Motor	1

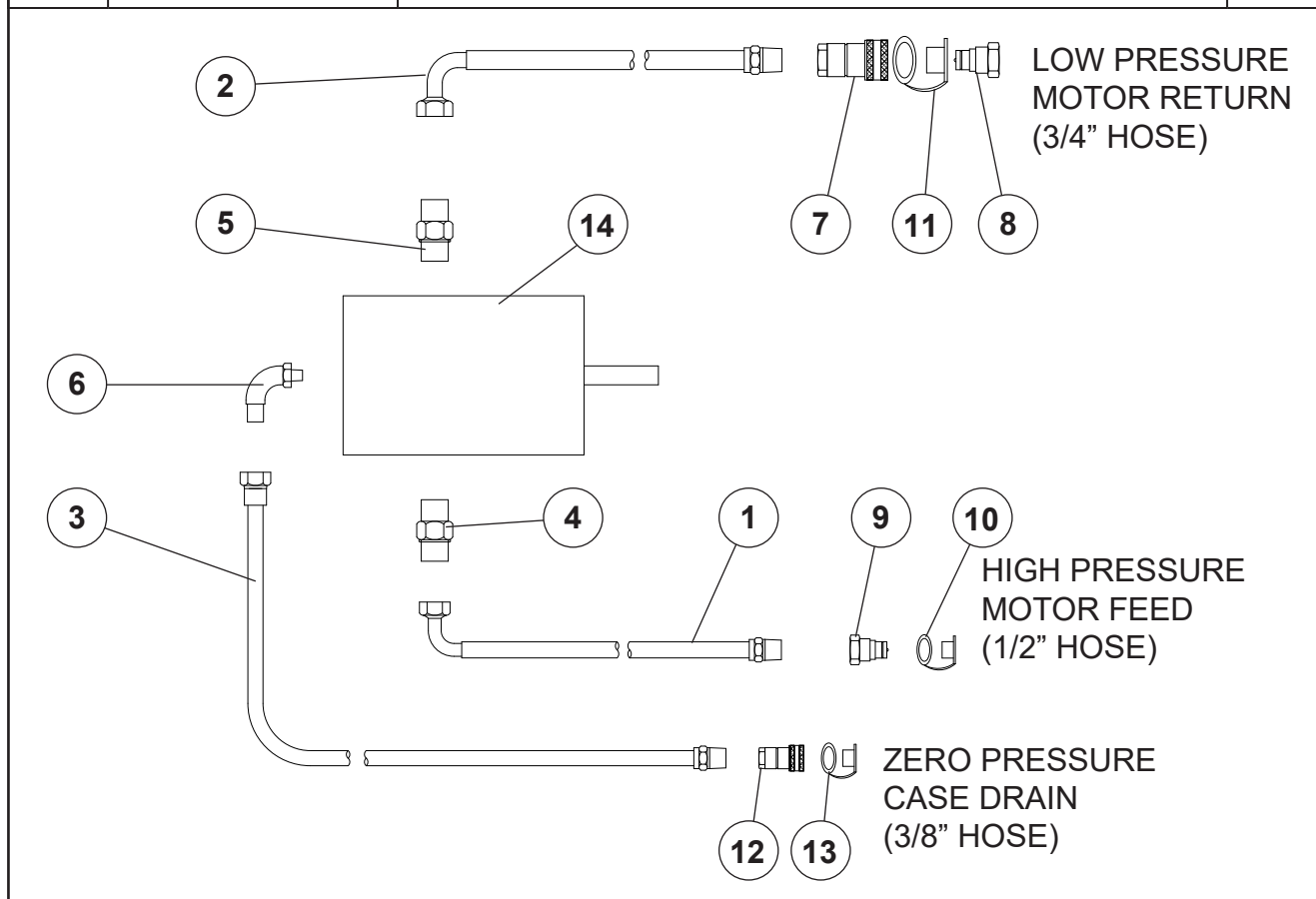

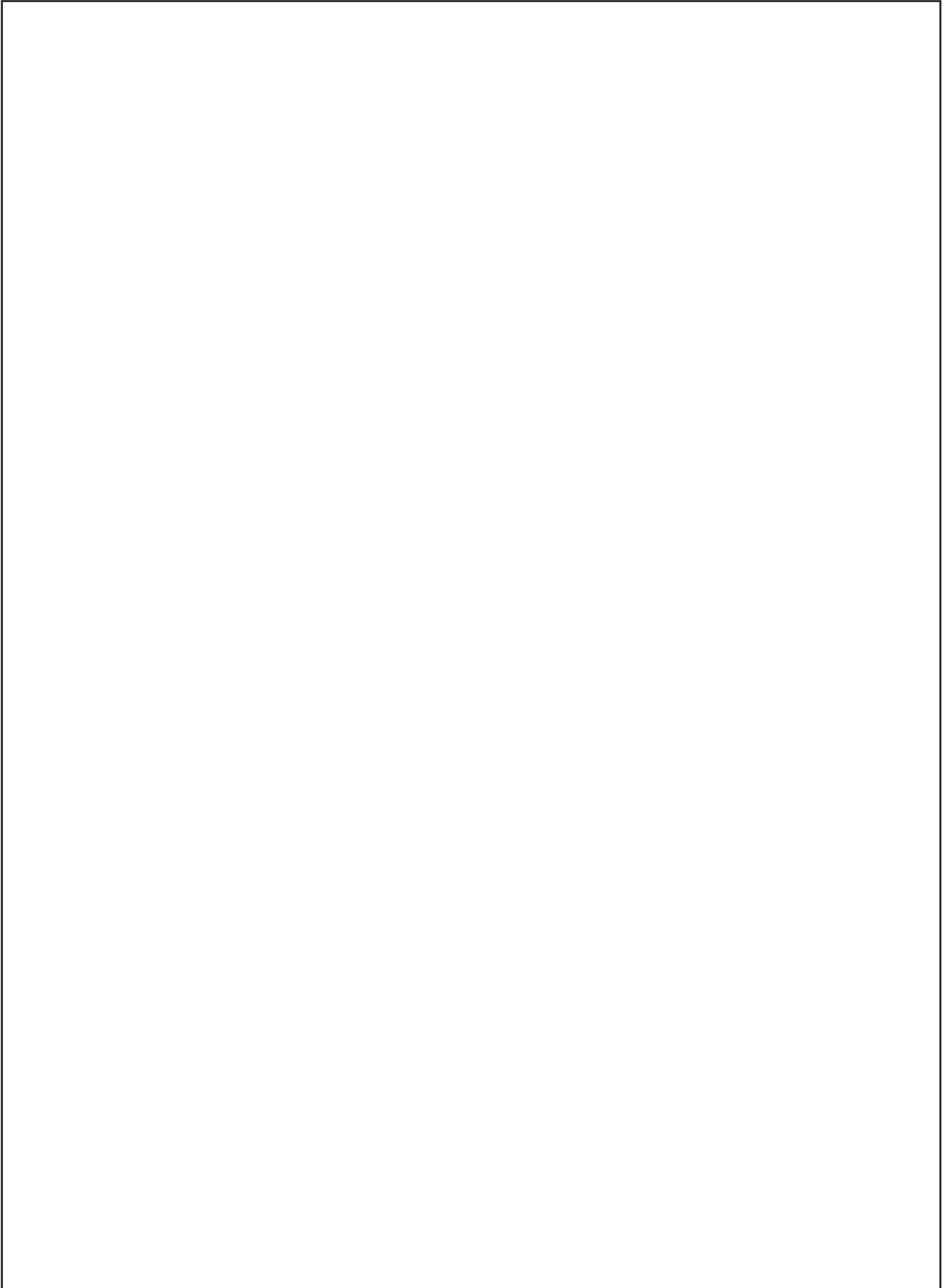

'Enviro DD30'

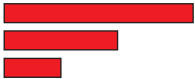

'Enviro DD30' Hose Connection Colours

Used On...	Hose Function	Wrap Colour	Length/Diameter (mm)	Material Part No.	Description
AS3000/3500/4000, DD30/35/45/50/55, AS53/61	Blower Pressure	RED	350 long Ø25	48089	25mm Coiled Hose Armour/M (RED)
	Blower Return	RED	250 long Ø32	48091	32mm Coiled Hose Armour/M (RED)
	Blower Case Drain	RED	150 long Ø20	48086	20mm Coiled Hose Armour/M (RED)
AS3000/3500/4000, DD30/35, AS53/61	Wheels Lift	BLUE	250 long Ø20	48085	20mm Coiled Hose Armour/M (BLUE)
	Wheels Lower	BLUE	150 long Ø20	48085	20mm Coiled Hose Armour/M (BLUE)
DD45/50/55	Wheels Lift	BLUE	250 long Ø25	48088	25mm Coiled Hose Armour/M (BLUE)
	Wheels Lower	BLUE	150 long Ø25	48088	25mm Coiled Hose Armour/M (BLUE)
AS53/61	Wings Fold Up	YELLOW	250 long Ø20	48087	20mm Coiled Hose Armour/M (YELLOW)
	Wings Fold Down	YELLOW	150 long Ø20	48087	20mm Coiled Hose Armour/M (YELLOW)
DD45/50/55	Wings Fold Up	YELLOW	250 long Ø25	48090	25mm Coiled Hose Armour/M (YELLOW)
	Wings Fold Down	YELLOW	150 long Ø25	48090	25mm Coiled Hose Armour/M (YELLOW)

	Blower RED	Pressure Return Case Drain		Hose Connection Colours
	Wheels BLUE	Lift Lower		
	Wings YELLOW	Fold Up Fold Down		

'Enviro DD30' Weighing Kit

ITEM	PART No.	DESCRIPTION	QTY
1	43455	Electronic Scales Model Nwth10	1
2	43456	Desktop Calculator 86632994	1
3	43457	Sistema Klip It Plastic Container	2
4	43975	HD Cardboard Box 380X275x140	1
5	67394	Owners Manual DD Enviro Air	1

'Enviro DD30' Jackal

ITEM	PART No.	DESCRIPTION	QTY
KIT	44026K	Contains the following:	
1	44027	Jackal v3.5 Monitor and Control Speed, Area Meter and Fan	1
2	44037	Owner's Manual Jackal v3.5 Monitor and Control Speed	1
3	44028	Window Mount AH-407	1
4	44576	11 way Terminal Block P322 Grey	1
5	44146	11 way Terminal Block P321 Green	1
6	-	Cable S/Assy Jackal v3.5 (2 x 3way)	1
7	44029	Power Cable AC-105	1
8	48027	7.5m Cable (3 way) (AC-487-7,5m)	2
9	-	Proximity Sensor M12 (AA-487)	2

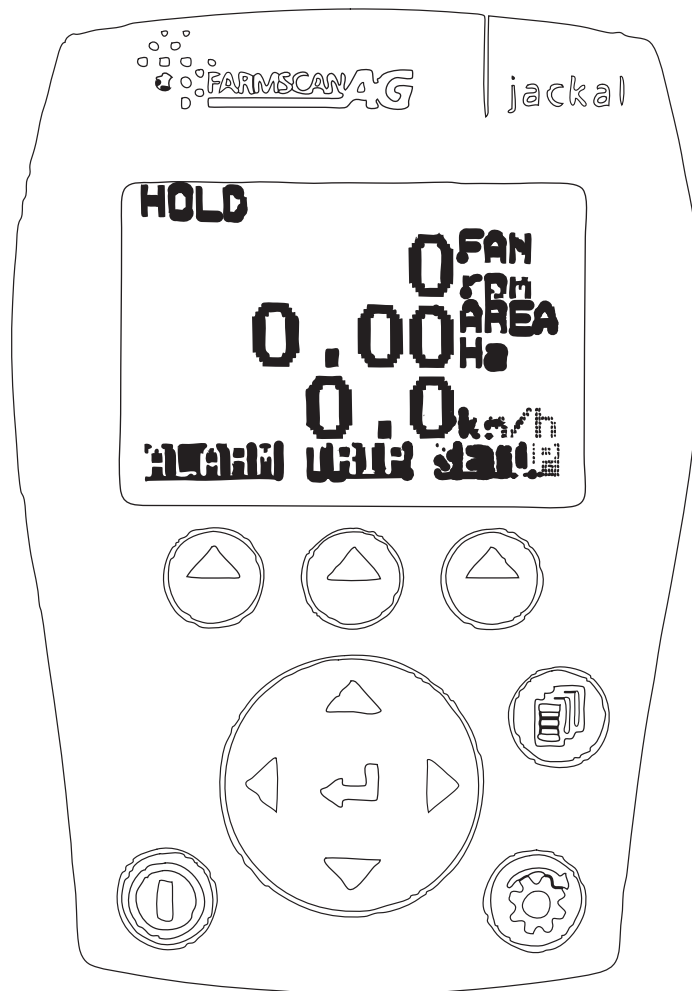

'Enviro DD30' Lighting (Optional)

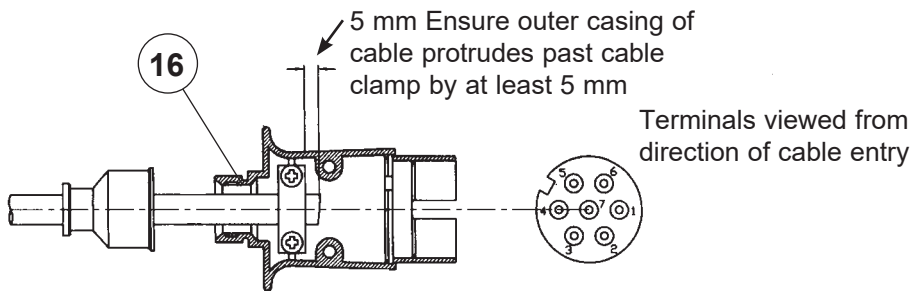
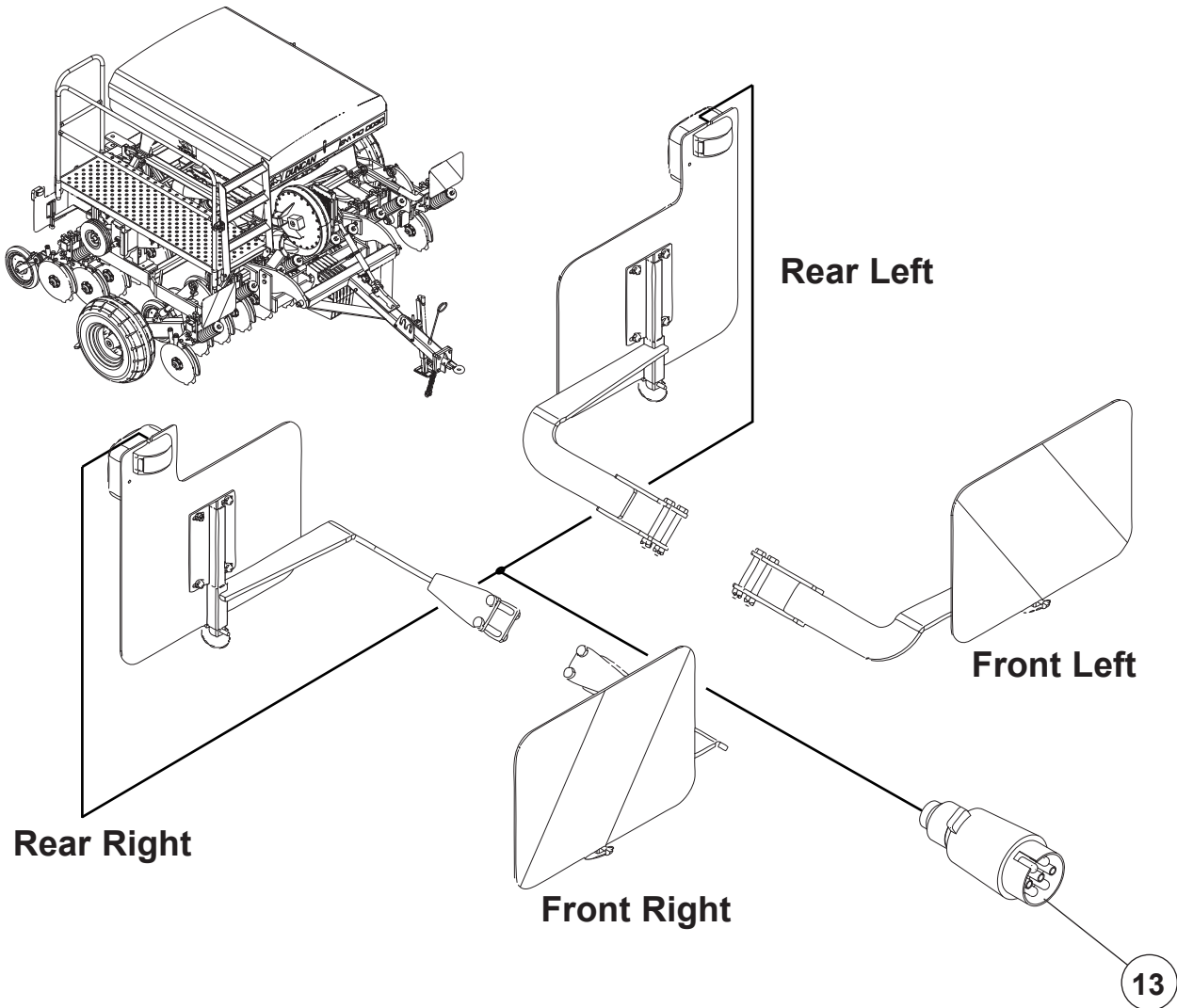

Cable Colour	Terminal Number	Function
Yellow	1	Left Indicator
White	3	Earth
Green	4	Right Indicator
Red	6	Brake/Stop
Brown	7	Tail/Side Lights

'Enviro DD30' Lighting (Optional)

ITEM	PART No.	DESCRIPTION	QTY
KIT	62975K	Contains items 1 to 15:	
1	45664	Hazard Decal Full Set	2
2	61718P#	Hazard Panel Front Profile	2
3	61719P#	Hazard Panel Rear Profile	2
4	61715	Viz Plate Holding Bracket	4
5	61709	FR-LH/RR-RH Viz Frame (Front left or Rear right)	2
6	61710	FR-RH/RR-LH Viz Frame (Front right or Rear left)	2
7	45013	M10 x 80 Grade 8.8 Z/P Bolt	8
8	45138	M10 Nyloc Nut	8
9	45908	M6 x 16 Pan Pozi Z/P	16
10	45150	M6 Light Flat Washer	16
11	45136	M6 Nyloc Nut	16
12	43675	1/4" X 1 1/2" Linch Pin	4
13	60881	Loom (includes Plug and LED lights prewired)	1
14	43333	Plastic Tie Strap	12
15	47620	"P" Clip	4
16	43437	Trailer Round Connector Plug (spares)	1

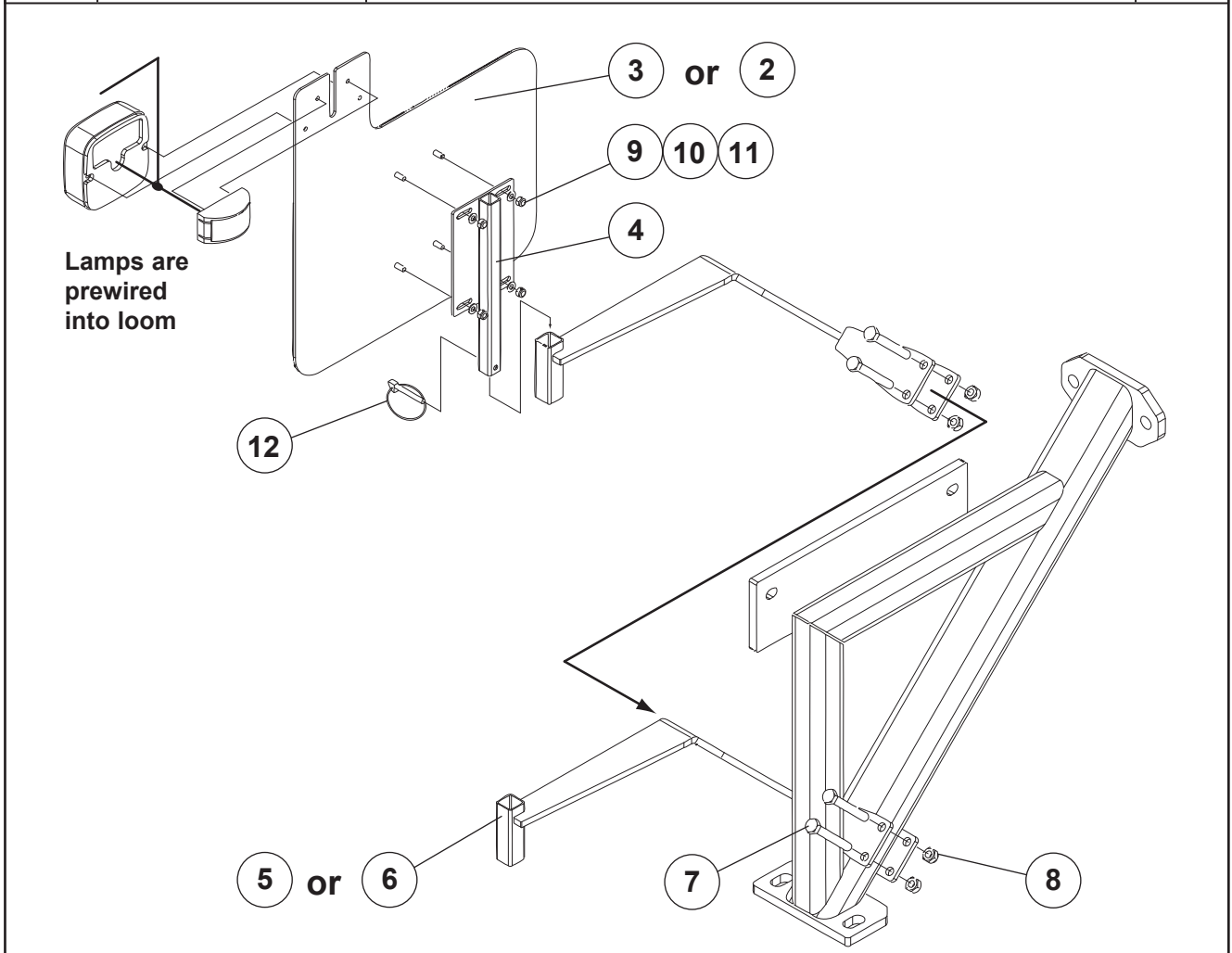

'Enviro DD30' Rear Tow Hitch (Optional)

The Disc Units
have been hidden
for clarity

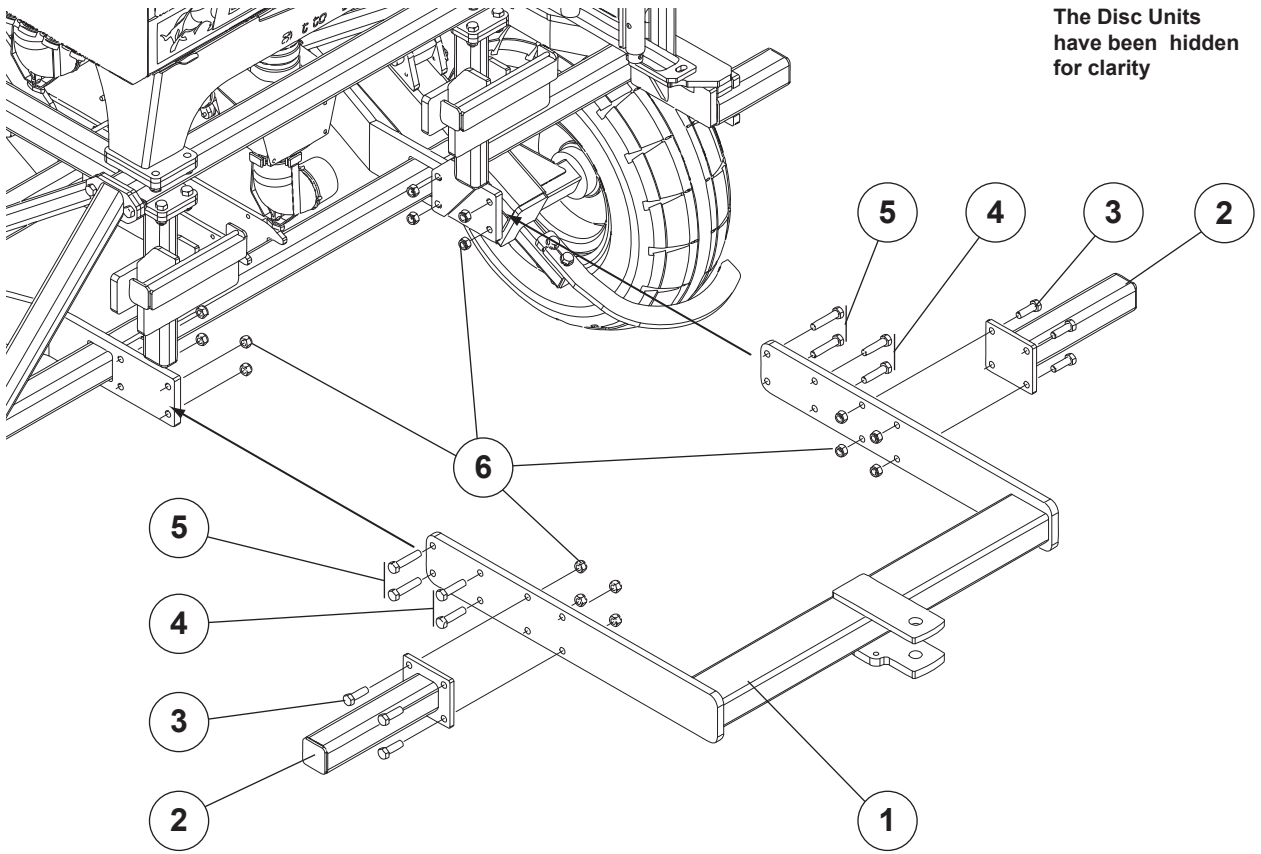

'Enviro DD30' Rear Tow Hitch (Optional)

ITEM	PART No.	DESCRIPTION	QTY
1	63035	Rear Towhitch Welded Assembly	1
2	63297	Tine Harrow Stub Assembly	2
3	45040	M16 x 50 Grade 8.8 Z/P Bolt	8
4	45043	M16 x 65 Grade 8.8 Z/P Bolt	4
5	45045	M16 x 75 Grade 8.8 Z/P Bolt	4
6	45140	M16 Nyloc Nut	16

Note: Item 2 (1 per side) is required if a Tine Harrow is to be fitted.

'Enviro DD30' Tine Harrow (Optional)

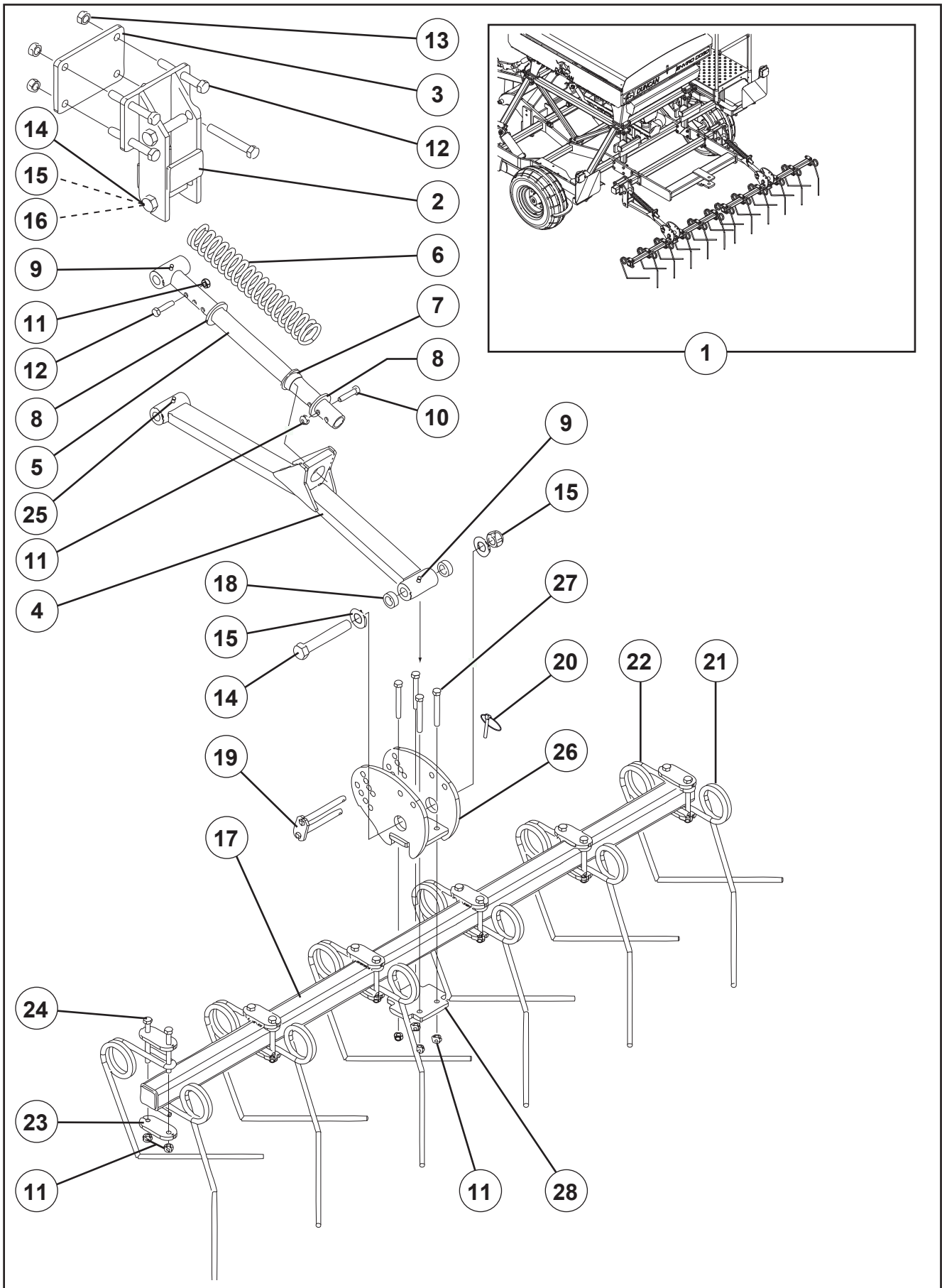

‘Enviro DD30’ Tine Harrow (Optional)

ITEM	PART No.	DESCRIPTION	QTY
1	RFT30	Tine Harrow for Enviro DD30 Air	1
2	60426	Tine Harrow Strut W/Assy	2
3	60428	Strut Bolt Plate	2
4	60430	Swinging Arm W/Assy	2
5	60435	Guidingbar W/assy	2
6	60437	Levelling Harrow Spring	2
7	60438	Guiding bar Bush	2
8	60439	Guiding Spacer	4
9	43118	Grease Nipple Straight	2
10	45006	M10 X 45 Gr 8.8 bolt Z/P	4
11	45138	M10 Nyloc Nut	36
12	45050	M16 X 120 Gr 8.8 bolt Z/P	8
13	45140	M16 Nyloc Nut	8
14	45073	M20 X 130 Gr 8.8 bolt Z/P	6
15	45161	M20 HD flat washer Z/P	4
16	45141	M20 Nyloc Nut	6
17	60423	Levelling Harrow Bar W/Assy	2
18	60440	Swinging Bracket Spacer	4
19	60441	Levelling Harrow Pivot Pin W/Assy	2
20	43675	1/4" x 1 1/2" Lynch Pin	2
21	60255	Levelling Harrow Tine -LH	12
22	60256	Levelling Harrow Tine -RH	12
23	60422P#	Double Retaining Plate Profile	24
24	45016	M10 X 100 Gr8.8 Bolt Z/P	24
25	43120	Grease Nipple 90°	2
26	60421	Tine Harrow Bracket	2
27	45013	M10 x 80 Gr 8.8 bolt Z/P	8
28	60420	Harrow Bar Clamp Plate	2

Note: The Rear Tow and Tine Harrow Mounting kit are required (see previous page)

'Enviro DD30' Uni-Roller (Optional)

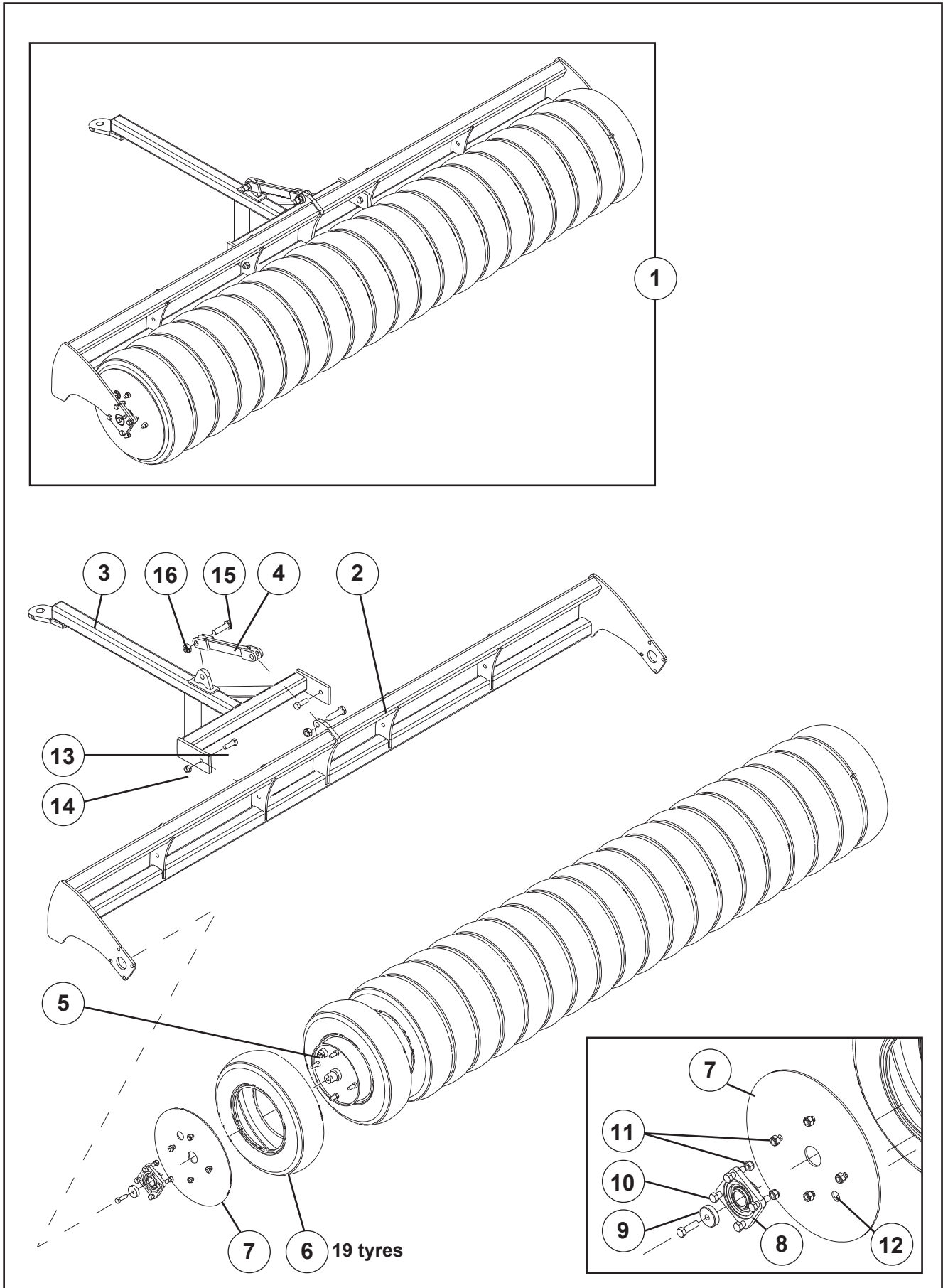

‘Enviro DD30’ Uni-Roller (Optional)

ITEM	PART No.	DESCRIPTION	QTY
1	RTR30	Uni-Roller Complete	1
2	60475	Roller Frame W/Assy	1
3	60490	Drawbar Assembly Complete	1
4	60496	Link	1
5	60482	Roller Tube W/Assy	1
6	43589	Tyre 185/70 R13	19
7	60494	End Retaining Plate	2
8	43588	Bearing Unit	2
9	60495	Roller Axle Retainer	2
10	45041	M16 x 55 Class 8.8 Z/P Bolt	10
11	45140	M16 Nyloc Nut	16
12	43271	Drain plug	2
13	45064	M20 x 65 Class 8.8 Z/P Bolt	2
14	45141	M20 Nyloc Nut	2
15	47251	Bolt 1"UNF x 3.5" HT	2
16	47552	Nut 1" UNF Nyloc	2

'Enviro DD30' Weight Front (Optional)

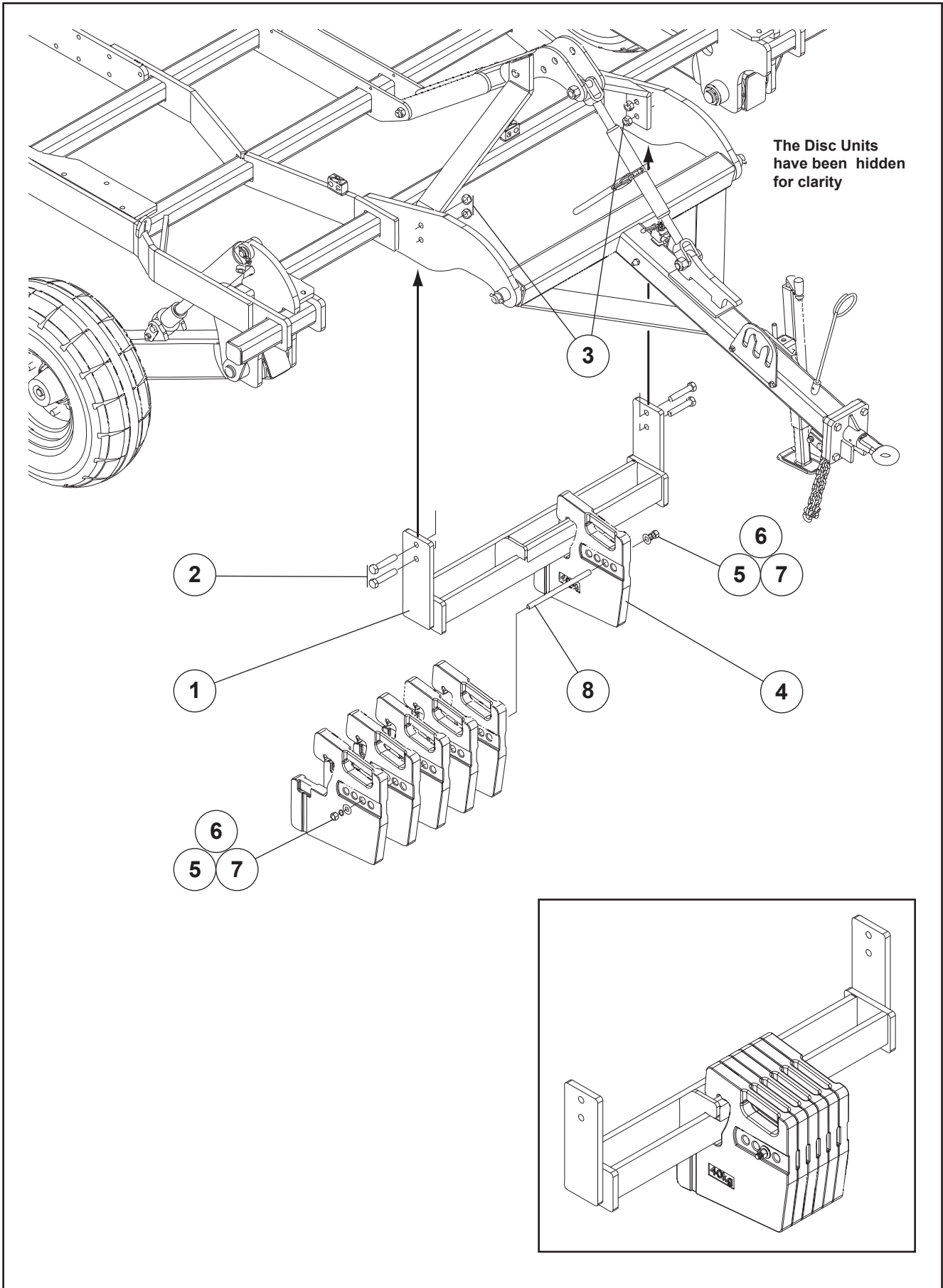

'Enviro DD30' Weight Front (Optional)

ITEM	PART No.	DESCRIPTION	QTY
1	63285	Front Wght Holding Brkt W/Assy	1
2	45069	M20 x 90 Grade 8.8 Bolt Z/P	4
3	45141	M20 Nyloc Nut	4
4	63273C	Case Weight 40kg	6
5	45160	M16 H/D Flat Washer Z/P	2
6	45168	M16 Spring Washer Z/P	2
7	45132	M16 Grade 8.8 Hex Nut Z/P	2
8	63275	Weight Holding Rod 300mm Long	1

Kit 62987K includes all mounting hardware for FRONT and REAR of machine but excludes weights (item 4)

'Enviro DD30' Weight Rear (Optional)

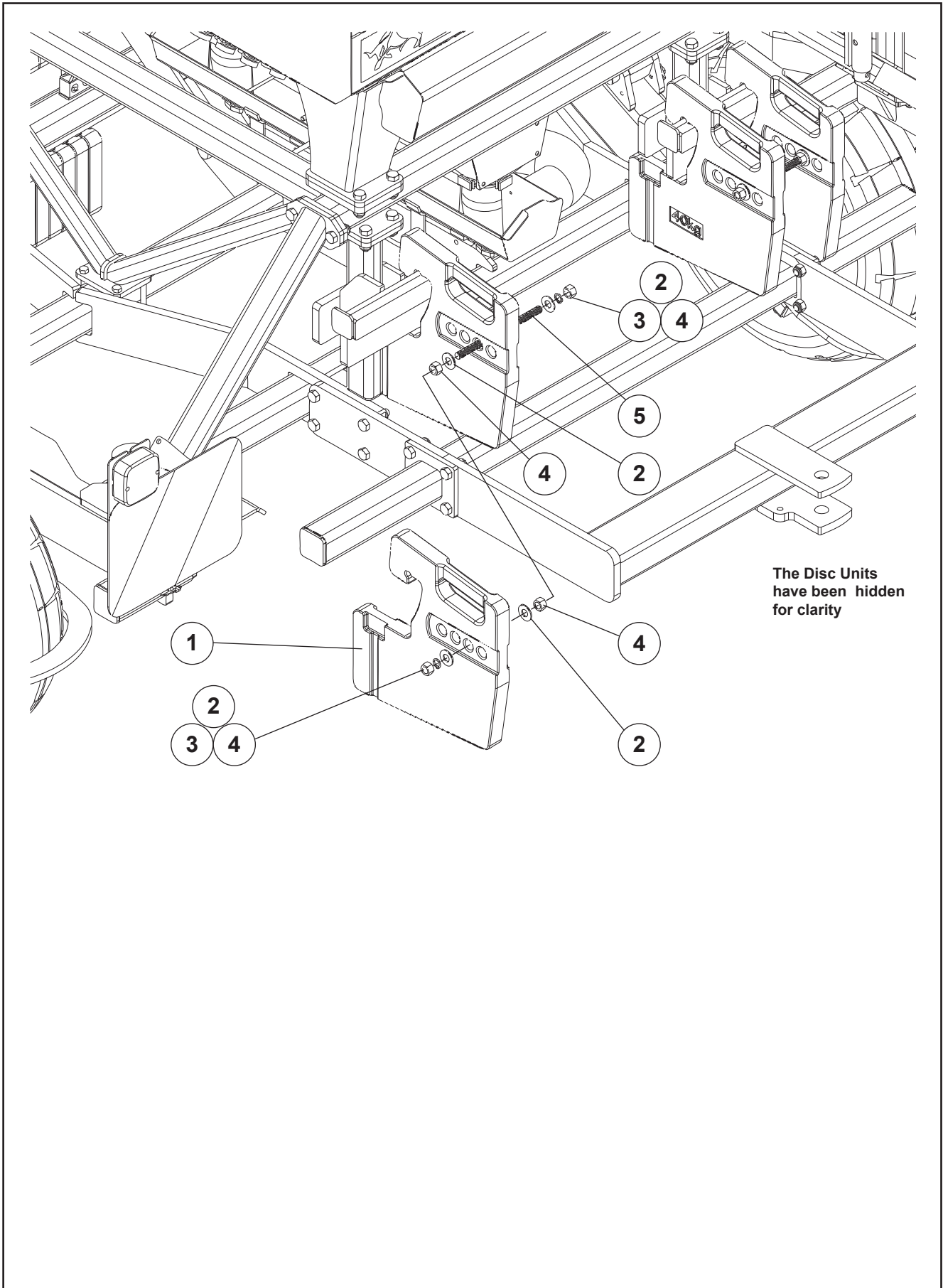

'Enviro DD30' Weight Rear (Optional)

ITEM	PART No.	DESCRIPTION	QTY
1	63273C	Case Weight 40kg	4
2	45160	M16 H/D Flat Washer Z/P	8
3	45168	M16 Spring Washer Z/P	4
4	45132	M16 Grade 8.8 Hex Nut Z/P	8
5	63274	Weight Holding Rod 250mm Long	2

Kit 62987K includes all mounting hardware for FRONT and REAR of machine but excludes weights (item 1)